



IMO-OMI



REGIONAL MARINE POLLUTION EMERGENCY
RESPONSE CENTRE FOR THE MEDITERRANEAN SEA
(REMPEC)



UNEP-PNUE



**PROGRAMME OF ACTIVITIES FOR THE DEVELOPMENT OF
NATIONAL CAPACITIES OF SERBIA AND MONTENEGRO FOR THE
PREVENTION OF, PREPAREDNESS FOR AND RESPONSE TO
MARINE POLLUTION FROM SHIPS**

ACTIVITY 6

**Assessment of the Existing Situation and Needs, Optimum
Solutions and Standard Designs for Collecting, Treating
and Disposing of Ship-Generated Solid and Liquid Wastes
in the Port of Bar, Montenegro**

FINAL REPORT

MARCH 2007



TEBODIN
Consultants & Engineers

**PROGRAMME OF ACTIVITIES FOR THE DEVELOPMENT OF NATIONAL CAPACITIES OF
SERBIA AND MONTENEGRO FOR THE PREVENTION OF, PREPAREDNESS FOR AND
RESPONSE TO MARINE POLLUTION FROM SHIPS**

ACTIVITY 6

**Assessment of the Existing Situation and Needs, Optimum Solutions and Standard Designs
for Collecting, Treating and Disposing of Ship-Generated Solid and Liquid Wastes in the Port
of Bar, Montenegro**

GENERAL INTRODUCTION

In June 2005, in the context of the process of ratification by Serbia and Montenegro of the Barcelona Convention for the Protection of the Marine environment and the Coastal Region of the Mediterranean and its Protocols, the Ministry for the Environment and Physical Planning of the Government of the Republic of Montenegro requested assistance from the Coordination Unit (MEDU) of the Mediterranean Action Plan (MAP) to identify possible areas of cooperation within the framework of MAP and specific actions to be carried out with the support of its Regional Activity Centres.

As a result, a comprehensive programme of activities in the field of marine pollution from ships was proposed by Regional Marine Pollution Emergency Centre for the Mediterranean Sea (REMPEC) to the competent national authorities of the Government of the Republic of Montenegro, which approved it.

A Memorandum of Understanding for the implementation of the programme of activities was signed in December 2005 between the Republic's Minister of Environmental Protection and Physical Planning, the Minister for Transport and Maritime Affairs and REMPEC.

The programme included a specific activity (activity 6) related to port reception facilities for collecting of ship-generated oily wastes and garbage, aimed at facilitating the implementation by Serbia and Montenegro of Annex I and Annex V of the International Convention for the Prevention of Pollution from Ships (MARPOL).

Under activity 6, the following tasks were carried out with the assistance of the consultancy firm selected by REMPEC (Tebodin B.V., the Netherlands):

- Assessment of the situation and needs regarding port reception facilities in the port of Bar, Montenegro;
- Proposals for optimum solutions for collecting, treating and disposing of relevant ship-generated solid and liquid wastes in the port of Bar, Montenegro; and
- Production of standard designs for the implementation of the proposed solutions.

The following is the final report produced by TEBODIN B.V. under the supervision of REMPEC.

The present document and related study have been produced with the financial assistance of the Regional Marine Pollution Emergency Response Centre for the Mediterranean Sea (REMPEC).

This study was executed by Tebodin Consultants and Engineers, The Netherlands, contracted by and under the responsibility of REMPEC.

The designations employed and the presentation of the material in this publication do not imply the expression of any opinion whatsoever on the part of IMO, UNEP, MAP and REMPEC concerning the legal status of any State, Territory, city or area, or its authorities, or concerning the delimitation of their frontiers or boundaries.

Table of contents		page
1	Port of Bar characteristics	3
2	Laws and regulations	5
2.1	International	5
2.1.1	Oily waste water	6
2.1.2	Garbage	6
2.2	National	6
2.2.1	Authorities	6
2.2.2	Laws	7
2.2.3	Inspections	7
3	Identification of required capacities	8
3.1	Shipping traffic data	8
3.2	Data on wastes	8
3.2.1	Liquid wastes	8
3.2.2	Solid wastes	9
3.3	Analysis and adequacy of existing installations	10
3.3.1	Private sector	10
4	Bilge water and oily wastes	11
4.1	Review of currently available technologies	11
4.1.1	Reception of oily waste water	11
4.1.2	Treatment technologies	13
4.2	Proposal and analysis of the optimum solutions for bilge water and oily wastes	14
4.2.1	Collection	14
4.2.2	Treatment	15
4.2.3	Treatment capacity	15
4.2.4	Basis of design	16
4.3	Investment costs	16
4.4	Drawings and technical drawings	18
5	Garbage	18
5.1	Landfill	18
5.2	Groundwater monitoring	18
6	Conclusions	21
Annex A: Terms and definitions		22
Annex B: Port drawing on present situation		25
Annex C: Distribution of ship calls and tonnages in year 2005		27
Annex D: Design calculations		28
Annex E: Process flow diagrams		29

Annex F: Lay-out and site plan	32
Annex G: Pictures of Hemosan Oily water treatment facility in Zelenika	35
Annex H: Functional Specification	38

Assessment of the Existing Situation and Needs. Optimum Solutions and Standard designs for Collecting, Treating and Disposing of Ship-Generated Solid and Liquid Wastes in the Port of Bar, Montenegro

Introduction

The Regional Marine Pollution Emergency Response Centre for the Mediterranean Sea (REMPEC), a Regional Activity Centre within the Mediterranean Action Plan (MAP) of the United Nations Environment Program (UNEP) administered by the International Maritime Organisation (IMO), is currently carrying out the programme of activities entitled "Development of National Capacities of Serbia and Montenegro of Prevention of, Preparedness for and Response to Marine Pollution from ships". Activity 6 of the programme of activities concerns port reception facilities in the port of Bar. The present study is the result of the assessment carried out in the port of Bar by Tebodin Engineers, which was hired by REMPEC.

This study concerns the identification of required capacities for waste collection and treatment in the port of Bar, proposals for optimum solutions and the production of standard designs and specifications.

Study

Chapter 3 of the study assesses the present situation of port reception facilities in Serbia and Montenegro, while chapter 4 and 5 present the optimum solutions for collection, treatment and disposal of relevant types of ship generated solid and liquid waste for a number of relevant ports/terminals. The study compiles experience about port reception facilities in many ports worldwide as well as waste management techniques (BAT – Best Available Techniques).

The standard designs and specifications represent the functional specifications of the required collection and treatment facilities in the Port of Bar. These technical specifications were developed to be issued as tender documents, either directly to possible contractors, or to seek funding from donor agencies and financial institutions for the setting up of facilities for the reception and treatment of garbage and oily wastes.

Meetings and sources

As a part of the assessment, a fact finding mission was carried out. In Serbia and Montenegro the port of Bar has been visited as well as Bijela Adriatic Shipyard. The following organizations are involved and have been contacted:

- The Port of Bar;
- The Maritime Safety Department;
- The ministry of Maritime affairs;
- The Ministry of Environmental Protection (by telephone);
- Bijela Adriatic Shipyard;
- Hemosan (private company);

Assessment of the Existing Situation and Needs. Optimum Solutions and Standard designs for Collecting, Treating and Disposing of Ship-Generated Solid and Liquid Wastes in the Port of Bar, Montenegro

During the mission, meetings have taken place with the responsible persons of all involved organizations as well as with the persons on an operational level. They have provided valuable information and as such given an important contribution to the writing of this mission report.

Mr. Celebic	Director of strategic development	PoB
Ms. Marstijepovic	Officer for environmental issues	PoB
Mr. Novovic	Assistant manager of development division	PoB
Capt. Rakocevic	Senior advisor for implementation of international regulations	MSD
Ms. Knezevic ¹	Advisor in the Ministry of environmental protection	MEP
Mr. Nikitovic	Director of Hemosan	Hem
Mr. Pesikan	Department manager Safety and environment	BS

¹ Ms. Knezevic from the Ministry of environmental protection was not able to attend the meeting. The consultant spoke to her by phone.

1 Port of Bar characteristics

The port of Bar is the main gate to the sea of Montenegro and it handles the majority of the international maritime cargo. It is sheltered by two breakwaters, one at the west side and one at the north side. The port entrance between the breakwater heads is 200 m wide with a water depth of 14 m. For ocean-going vessels, 2.700 m berth length is available and 750 m for passenger and coastal vessels. The Port of Bar has a total port area of approximately 200 ha and the following terminals can be distinguished from south to north:

Liquid (chemical) bulk

The liquid bulk cargo terminal has operational berths with a water depth of 12.5 m for the loading and unloading of oil, oil products and chemicals. The terminal is provided with tanks with a storage capacity of 120.000 m³, including a discharging installation for acetic acid with a capacity of 600 tons per hour.

Oil tankers

At present Oil tankers only use the terminal owned by Jugopetrol. The oil terminal of Jugopetrol is not a part of the Port of Bar. Jugopetrol used to be a state owned company. At the time of the assessment, it was stated by the Port of Bar that Jugopetrol has been a private company for four years now.

The Port of Bar does however wishes to expand there liquid terminal capacities with oil derivatives' tanks, basic oil tanks and tanks for edible ad other types of oil

Dry bulk

The dry bulk cargo terminal is specialised for the handling and storage of ores and concentrates, alumina clay and other dry bulk cargoes. The terminal is located on the quay of Volujica with two berths of 550 m and a water depth of 12 m. The terminal includes three gantry cranes with 12 tons lifting capacity, three railway tracks under the cranes and a storage area of 50,000 m². The quay length can be extended with 250 m. The following specific facilities are available in the Port of Bar:

- Silo for alumina clay (20.000 tons);
- Tanks for lye or caustic soda (10.000 tons);
- Storage facilities for bulk cement (3.000 tons).

The grain terminal is located adjacent to the dry bulk terminal. The terminal designed for handling cereals, includes a silo with 30,000 tons capacity. A 250 m long closed conveyor belt system has been provided parallel to the quay line for the transport of grains to and from the silo. For the vessel unloading operations, the gantry cranes with 12 tons lifting capacity are used. For loading the grains on rail and road vehicles, a loading tower (hopper) is used with a capacity of 300 tons per hour.

Containers

The container terminal has 330 m of operational quay length with a water depth of 12 m. The terminal covers 60,000 m² (two-third of the Pier I area) and may be expanded to 80,000 m². One container gantry crane with a lifting capacity of 40 tons is available. Three lift trucks are applied in the container storage area. The maximum stacking height is three. The stacking pattern related to the use of lift trucks results in a less effective use of space. Facilities are available for the connection of reefer containers (40 connection points) to the electricity network, as well as facilities for stripping and

Assessment of the Existing Situation and Needs. Optimum Solutions and Standard designs for Collecting, Treating and Disposing of Ship-Generated Solid and Liquid Wastes in the Port of Bar, Montenegro

stuffing (Container Freight Station or CFS), repair, washing, and cleaning of containers. Tractors and trailers are available for horizontal transport of containers.

General cargo

The timber terminal is located at the back of Pier I. It includes a/o:

14,400 m² of covered storage space;

5,000 m² of covered drying space;

4,800 m² of covered space for sorting and finishing.

The general cargo terminal has 1,370 m of operational quay length with a water depth of 10 m. The storage areas include 120,000 m² of covered and 510,000 m² of open storage area. A warehouse for temperature controlled storage of goods (4,500 tons) is available as well. The equipment include 2 ship-to-shore portal cranes with a lifting capacity of 20 tons and 12 small old (Ganz) cranes with a lifting capacity of 3 to 8 tons.

Roll on/Roll off

Roll on/Roll off (ro/ro) operations are carried out via the specialised ramp at Pier I at the end of the quay wall of the container terminal. At Pier III and Pier V ro/ro operations are carried out for vessels with their own ramp. Parking space for ro/ro vehicles is provided at the open storage space of 60,000 m² at the rear side of Pier III.

Passengers

The passenger terminal for the handling of passenger vessels and ferries is located at the north side at the pier separating the commercial port and the marina. Passenger reception and waiting facilities including those for customs are available. A parking area for road vehicles transported by ro/ro vessels is provided at the pier.



2 Laws and regulations

This chapter describes the international regulations regarding prevention of pollution caused by ships generated wastes and the provision of reception facilities for ship generated wastes at ports. Furthermore it describes if and in what way, the MARPOL Convention has been implemented by the Government of Serbia and Montenegro.

2.1 International

The MARPOL Convention and its annexes deals with the prevention of oil and garbage pollution from ships.

Annex I of MARPOL Convention contains regulations and interpretations related to procedures for the retention onboard, treatment, discharge at sea and disposal of oily mixtures generated in the machinery spaces of all ships and the cargo areas of oil tankers.

Annex V, similarly, contains regulations dealing with the storage, disposal and management in general of garbage produced onboard ships.

Assessment of the Existing Situation and Needs. Optimum Solutions and Standard designs for Collecting, Treating and Disposing of Ship-Generated Solid and Liquid Wastes in the Port of Bar, Montenegro

2.1.1 Oily waste water

Regulation 9 of Annex I of MARPOL Convention provides requirements with respect to the control of discharges of oily mixtures produced in the cargo and ballast areas of oil tankers.

In principle, this kind of discharge is prohibited within the Mediterranean Sea, as a designated Special Area, except of clean or segregated ballast.

2.1.2 Garbage

Regulation 5 of Annex V of MARPOL Convention provides requirements for the disposal of garbage within special areas. In accordance with the provisions of this Regulation, disposal into the sea of the following items is prohibited:

- All plastics, including but not limited to synthetic ropes, synthetic fishing nets, plastic garbage bags and incinerator ashes from plastic products which may contain toxic or heavy metal residues; and
- All other garbage, including paper products, rags, glass, metal, bottles, crockery, dunnage, lining and packaging materials.

Disposal into the sea of food wastes shall be made as far as practicable from land, but in any case not less than 12 nautical miles from the nearest land which is the baseline from which the territorial sea under the jurisdiction of each coastal state is measured.

2.2 National

The international Convention MARPOL has been ratified by the Government of Serbia and Montenegro. Its ratification has been announced in the National Gazette of the Republic of Yugoslavia No. 002/85-59.002/85-65. (succession 13.03.2003.) - IMO DOC.NO.PMP 5/Circ.61.

2.2.1 Authorities

The ministry of environmental Protection and Physical planning (MEPPM) is the key environmental authority in the Republic of Montenegro. It is responsible for the Law on Environment. The competence of the MEPPM includes;

Assessment of the Existing Situation and Needs. Optimum Solutions and Standard designs for Collecting, Treating and Disposing of Ship-Generated Solid and Liquid Wastes in the Port of Bar, Montenegro

- environmental protection systems;
- sustainable use of natural resources;
- protection of nature and biodiversity;
- protection of marine life;
- hazardous waste;
- strategic environmental impact assessment;
- integrated pollution prevention and control;
- economic instruments and eco-management;
- environmental standards;
- environmental monitoring;
- information system of environmental protection
- air, noise, vibration and hazardous substances;
- nature conservation and protected areas management;
- waste management, inspection and enforcement

The MEPPM as a national authority therefore, is responsible for the implementation of international resolutions regarding the environment. The Maritime Safety Department and the Port State Control are responsible for marine environmental protection regarding pollution from ships and disposal of the waste from ships.

2.2.2 Laws

As a signatory party to the International Convention MARPOL and its annexes, dealing with the prevention oil and garbage pollution from ships, the Government of Serbia and Montenegro has two laws under preparation;

- Law on the protection of the sea from pollution from ships
- Law on ports

At this moment there are no national regulations defining that a port in Serbia and Montenegro should provide waste reception facilities for ships.

2.2.3 Inspections

The Port Authorities of Serbia and Montenegro are not required to have an approved waste management plan. However, Ships calling at the port of Bar are subject to inspections by the Port State Control and the Maritime Safety Department. These inspections are carried out to verify compliance with MARPOL Annex I and V and EU directive 2000/59/EC. Although the annexes and directive have not been implemented in national law for now, they are used to carry out the inspections.

Inspections are made to the waste record books, oil record book, test records of the oil separators and other waste facilities on the ship.

3 Identification of required capacities

3.1 Shipping traffic data

The number of ships that visit the Port of Bar has increased the last three years. Unfortunately at this moment we only have data on the year 2005. Taking into consideration the fact that earlier data on shipping traffic is not very representative, because of the unstable political situation, we have to work with these data.

The shipping data for the year 2005 have been obtained from the Port of Bar. It was stated by the Port of Bar these data are a rough estimate. Furthermore they have stated that the estimate has been based on the number of ships calling the port, days at sea and the number of days in the port. No information could be obtained on the state of repair and average age of the ships.

In general the last port of call for the ships entering the Port of Bar is the Port of Piraeus (Greece). In less the 2% of the cases the last ports of call are Odessa (Ukraine), Burgas (Bulgaria), Novorosijsk (Russia)

These are the most accurate data we could obtain from the relevant authorities.

An overview of the shipping data estimated by the Port of Bar is presented in Annex C. The liquid bulk carriers in Annex C refer to chemical carriers. They unload their cargo at Port of Bar, but no tank washings take place. Port of Bar has stated they do not intend to put up tank washing activities for chemicals in the Port of Bar.

The traffic data given to us by the Port of Bar have been extrapolated from the year 2005 to create a basis of design for the reception facilities.

3.2 Data on wastes

There are no accurate data on waste quantities collected and reported in the Port of Bar. In order to make calculations an estimate of wastes has been made by the Port of Bar.

3.2.1 Liquid wastes

At present no collection of the mentioned oily waste waters is actually collected at the Port of Bar. Yet an assessment has been made on what would have been collected, had there been proper facilities.

Assessment of the Existing Situation and Needs. Optimum Solutions and Standard designs for Collecting, Treating and Disposing of Ship-Generated Solid and Liquid Wastes in the Port of Bar, Montenegro

Months	Sludge and bilge waters (m³)	Oily tank wash waters (t)
Jan-05	257,5	1677,86
Feb-05	320	1435
Mar-05	376	3382,44
Apr-05	382	2157,89
May-05	448	5764,3
Jun-05	387	2108,55
Jul-05	470,5	4042,22
Aug-05	409,5	3316,8
Sep-05	349,5	3870,25
Oct-05	412,5	3557,16
Nov-05	301	2580
Dec-05	415,5	2616,5
Total	4529	36508,97

Table 3.1 : Assessment of waste water quantities in port of Bar for 2005

3.2.2 Solid wastes

Ship-generated waste can be divided into domestic waste and operational waste, the latter consisting of cargo-associated waste and maintenance waste. The Port of Bar has been able to provide us with an assessment on the amounts of a part of the maintenance waste (table3.2).

Furthermore an overview is given for the other types of waste with typical /average figures for ship-generated wastes.

Oily rags and cotton wastes (kg)
831
1023
1171
1200
1375
1223
1472
1265
678
1170
939
1352
13699

Table 3.2: Assessment of oil contaminated textile quantities

Assessment of the Existing Situation and Needs. Optimum Solutions and Standard designs for Collecting, Treating and Disposing of Ship-Generated Solid and Liquid Wastes in the Port of Bar, Montenegro

Usually about 1,5 – 2,5 kgs of domestic waste is generated on a daily basis per person on a commercial cargo ship. On average, 75% weight and 10% per volume of domestic waste is food. The remaining 25% per weight and 90% per volume consist of paper products, textiles, glass, rags, bottles, plastics etc.

Operational waste consisting of dunnage, pallets, paper and cardboard material, wire, strapping etc., is the largest source of ship-generated solid waste.

The Port of Bar collects garbage but does not measure or register collected amounts. The collected garbage is transported by a lorry to the city dump. At present there are no recycling or incineration facilities in Serbia and Montenegro.

3.3 Analysis and adequacy of existing installations

At this moment Port of Bar does not have the installations to receive waste water from ships. The port does however receive garbage from ships. A regular lorry is used to transport the garbage to the city dump. There are no data available on the amounts of garbage that are being accepted by the port.

3.3.1 Private sector

During the mission a private company (by the name of Hemosan) was also visited by the consultant. The company has expressed its intention to build and operate a waste water treatment facility. At this moment the company has a small facility at Bijela Adriatic Shipyard. Pictures of this facility can be found in Annex G. The company is now called in case of an emergency due to oil spilling in the sea. At Bijela Adriatic Shipyard there is a small water/oil separator, which is used to treat water that is collected during these cleaning activities.

The company has knowledge about the treatment and separation of oily waste water. What is lacking is the financial means to build a facility at the Port of Bar.

4 Bilge water and oily wastes

4.1 Review of currently available technologies

In the following paragraphs an overview of current available technologies is given. Section 1.1.1 describes different techniques of waste water collection and section 1.1.2 gives an overview of treatment technologies.

4.1.1 Reception of oily waste water

Delivery by the ship, collection, transport and final disposal of oily waste water are part of a whole chain of hazardous (safety, health, environment) activities requiring a lot of handling, which should be fit for purpose. It should be noted that MARPOL Convention requires the provision of adequate facilities to meet the need of ships without causing undue delay. Reception facilities for receiving oily waste water, namely bilge water and oily sludge, from ships must be adequate enough so that ships are not 'unduly delayed'. The 'adequacy' of such port reception facilities includes the capacity that should be at least appropriate in time and availability to respond to the continuing needs of ships using the port and the arrangements needed to facilitate the discharge of such wastes, including the delivery, collection, transport, treatment and final disposal of such wastes.

There are basically three options by which oily waste water from ships is delivered to a port reception facility.

Option 1: When a ship is alongside a berth/quay/jetty and oily wastes are discharged directly to a nearby port reception facility through a fixed shore pipeline. This could be in the form of a small reception station located at the quay, if, for example, the main reception facility is outside the port area.

Option 2: When a ship is alongside a berth/quay/jetty and oily wastes are pumped into waiting mobile tank trucks on the quay. The tank trucks then deliver the wastes to the main reception facility whereby the collected wastes are pumped into the system.

Option 3: When a ship is alongside a berth/quay/jetty, or at anchor, and oily wastes are pumped into a floating reception facility. This 'floating reception facility' can be a dedicated oily wastes water collection barge, which can be either a dump barge or a self-propelled barge, or it can be a normal bunker barge with dual purpose. This barge, after taking delivery of the oily wastes from the ship, will then go alongside the quay and either discharge the wastes directly to the reception facility or to the waiting tank trucks on the quay. In the latter case, the tank trucks will then deliver the wastes to the reception facility.

For all three options a central port reception facility is required. Such a facility must have all the necessary requirements, namely adequate arrangements to receive the oily waste water either directly from the ship or from the small reception station at the quay or from the tank trucks, separation/treatment capabilities and also pumping capabilities. Such a facility must, amongst other things, be highly reliable with a high level of safety and has minimum environmental impact.

For Option 1 fixed pipeline must be constructed from the main reception facility to the quay, or from the small reception station located within the port area. Standard hoses with standard international connections will also be required for connecting with the ship's discharge line and the fixed point ashore. If the main port reception facility is located outside the port area and a small reception station is used within the port area then tank trucks are required to transport the oily wastes from the small reception tank located on the quay to the main reception facility. These two facilities can also be connected by a fixed pipeline and the transfer from the small reception station to the main facility can be done by pumping through such a fixed pipeline.

For Option 2 a number tank trucks are required. The number and capacity of the tank trucks depend on the number, type, sizes and frequency of the ships visiting the port. However as a minimum, bearing in mind that such equipment can develop mechanical failures and therefore can go out of action, etc., 3 tank trucks are required.

For Option 3 primarily a floating barge is required. If the barge then cannot pump the oily wastes directly to the port reception facility then tank trucks are also required. The floating barge can come in the form of a dedicated oily wastes water collection barge, which can either be a dumb barge or a self-propelled barge, or it can be a normal trading bunker barge with dual purpose, that is as a bunker delivery barge and as an oily waste water collector. The latter is more commonly found in practice. The capacity / DWT of such a barge depends on the scope for which the barge is to be used and the demand in the port.

Assessment of the Existing Situation and Needs. Optimum Solutions and Standard designs for Collecting, Treating and Disposing of Ship-Generated Solid and Liquid Wastes in the Port of Bar, Montenegro

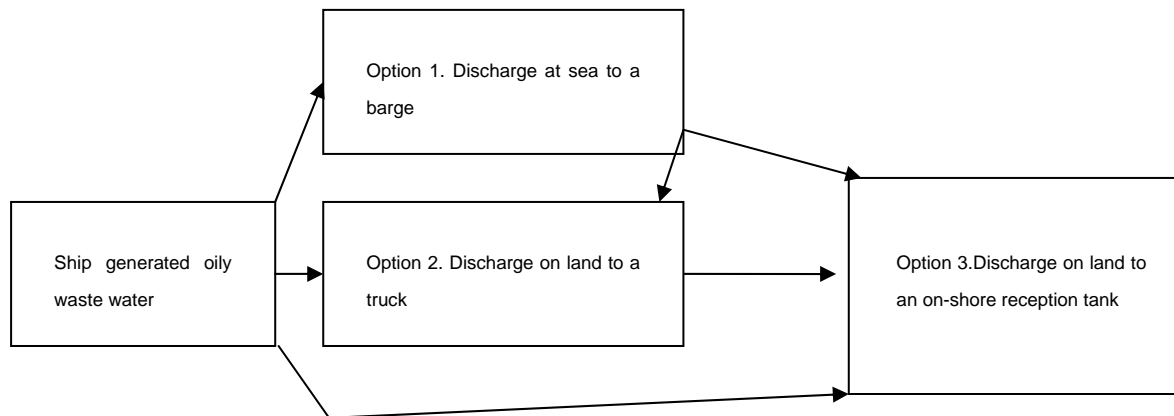

Figure 4.1: Different options for discharging oily waste

4.1.2 Treatment technologies

After the reception of the oily waste water, different treatment and separation technologies can be applied.

The treatment of ship generated oily waste water has two objectives; treatment of oily water and the sale of recovered oil. The oil is separated and sent to refining companies or waste oil users. The remaining oily water should be treated to break the water and oil emulsions and remove any remaining oil and toxins, before it can be safely discharged.

There are many different separation technologies, but most of them are as stand alone facility not suitable for the effective and complete treatment of ship generated oily waste water. A brief overview of the available technologies can be found in the table below.

Assessment of the Existing Situation and Needs. Optimum Solutions and Standard designs for Collecting, Treating and Disposing of Ship-Generated Solid and Liquid Wastes in the Port of Bar, Montenegro

Technology	Principle	Advantage	Disadvantage
Mechanical separators and centrifuges	Differential specific gravity between oil and water	No extra chemicals required	Don't break oil and water emulsions and do not remove the dissolved hydrocarbons in water
Biological water treatment	micro-organisms that transform undesirable substrate into biomass	Large amounts of waste water can be treated at once	Large varieties of inlet quality can lead to toxic shock. System is less qualified to treat saline waste water
Ultra filtration	Waste water is put through the filter under great pressure, leaving the oil on the filter	Membranes can be reused after cleaning	Membranes easily get fouled with oily waste water.
Media/cartridge filters	The cartridge is filled with a co-polymer. This element absorbs the hydrocarbons and bonds the oil.	Proved to be effective with oily waste	Filters must be changed regularly and disposed as hazardous waste

Table 4.1: Overview of treatment technologies

4.2 Proposal and analysis of the optimum solutions for bilge water and oily wastes

4.2.1 Collection

Different possibilities for the collection of oily waste water have been mentioned. The collection methods have different characteristics, which make them more or less suitable in different circumstances.

Collection method	Volumes/flow rates	Access to ships	Flexibility
Truck	Small	By road	High
Barge	Small/medium	By sea	Medium
Pipeline	Medium/large	Engineered solution	Low

Table 4.2: overview of collection characteristics

Assessment of the Existing Situation and Needs. Optimum Solutions and Standard designs for Collecting, Treating and Disposing of Ship-Generated Solid and Liquid Wastes in the Port of Bar, Montenegro

Considering the volumes of oily waste water to be collected at the Port of Bar are not very large, the use of collection barges is advised. In case smaller amounts of oily waste water need to be collected from ships, truck can be used.

4.2.2 Treatment

The technologies required to treat ship generated oily waste water should preferably include the following treatment steps;

1. Dewatering and settling tanks for gravity separation of oil;
2. Remove free oil and break the oily water emulsions;
3. Remove rest hydrocarbons and dissolved toxins;
4. If necessary; further treatment to meet the local environmental discharge requirements.

Furthermore the water treatment facilities should be suitable for the amounts of waste water, expected to be discharged at the Port of Bar.

The amount of ships calling at the Port of Bar has grown in the last three years according to the department of development. Nevertheless only data from 2005 could be reproduced and therefore used as a basis for our calculations. The anticipated amounts of future waste are therefore based on the 7% increase of calls, assuming that the increase in calls is proportional with the amount of bilge water and oily sludge.

The consultant has reviewed the distribution of the number of ship calls in time, expressed in calls/days to determine peak loads to the port reception facility and the number of required collection barges and trucks for unloading, based on the data for the year 2005, see Annex C.

4.2.3 Treatment capacity

Regarding the design of the port reception facility different factors are important, which will influence the required capacity. The following factors are applied to calculate the base case and the required capacity of the treatment units of the facility. Using the different factors (degrees of freedom), the effect on the capacity can be mitigated, as can be seen in Annex D.

- Factor (W) concerning assumed percentage of ship delivering waste to the port reception facility;
- Factor (M) concerning maximum of daily calls in 2005;
- Peak factor (P) expressing the accumulative number of extra calls during 5 days, also based on the same statistical data.
- Factor (Y) anticipating on future increase of number of calls with 7%, leading to a factor 2,7;
- Different factors (T) covering the time for days of no operation because of annual shut down (Ta), other scheduled non-operating days, forced maintenance time (Tc) and round the clock operation (Td).

The total factor is calculated through multiplying $(W \cdot M \cdot P \cdot Y \cdot T_a \cdot T_b \cdot T_c \cdot T_d)$.

Based on this method, the treatment capacity of the port reception facility is calculated at 20 m³/h.

4.2.4 Basis of design

The selection of the best option is based on an analysis of the best available techniques, the requirements concerning treated water and recovered oil, and the analysis in the previous sections. The best available techniques are considered in this design. Design calculation and extrapolation of the waste stream can be found in Annex D.

A modular design is proposed to cope with the anticipated future volumes up to 2015 or earlier/later depending on the actual future waste volumes, peak loads and the operational time. Moreover, it avoids investments now for waste volumes, which will be effectuated after 5 years or later, meanwhile relocating revenues from waste fees, which are imposed on all ships. This modular design comprises a future doubling of the proposed port reception facility while already providing now for the extension of the plot plan, the tank farm, the building and the necessary tie-ins. This way, the basis of design can easily be used in case of further future expansions.

The selected treatment technologies and main units are as follows;

Units	Tendering
1 Reception tanks	local fabrication
1 Slop oil tank	
1 Sludge buffer tank	
1 Corrugated Plate Interceptor	packaged unit 1
1 Flocculation and chemical dosing	packaged unit 2
1 Flotation unit	packaged unit 3
1 Decanter Centrifuge	packaged unit 4
1 Heating water unit	packaged unit 5
2 Lagoons	local civil contractor

Table 4.3: selected treatment technologies

The process flow diagrams are included in annex E. The design flow rate is 20 m³/h. Capacities and sizes of the different units are shown on the drawings.

4.3 Investment costs

A rough estimate of the capital investment costs (in €) for the design, engineering and construction of the proposed port reception facility has been determined as follows.

Assessment of the Existing Situation and Needs. Optimum Solutions and Standard designs for Collecting, Treating and Disposing of Ship-Generated Solid and Liquid Wastes in the Port of Bar, Montenegro

This price includes:

- engineering , procurement services, and construction supervision;
- local fabrication of tanks;
- supply free on site of treatment equipment using packaged units;
- laboratory equipment;
- electrical and control equipment;
- concrete building;
- tank farm, concrete pits, lagoons.

The selected material for tanks, process equipment and piping is SS316L, which is rather costly. Acquisition of the land, leveling costs, costs for roads and power feed supply are not included. Also the purchase price of the collection barge for bilge water and slop oil is not quoted.

The investment costs are based on Western European prices and man hour costs. Evidently, the investment costs of locally manufactured equipment and executed works are lower. Hence a multiplier could be adopted to convert the European prices to the Montenegrin level of prices.

Units	Tendering	Investment costs €
Engineering , Procurement, Construction supervision	International/national engineering company	550,000
1 Reception tank	local fabrication	700,000
1 Slop oil tank		
1 Sludge buffer tank		
1 Corrugated Plate Interceptor	packaged unit 1 to 5 international vendor	800,000
1 Flocculation and chemical dosing		
1 Flotation unit		
1 Decanter centrifuge		
1 heating water unit		
Building construction	local civil contractor	200,000
Civil construction of Tank slabs, concrete pits, lagoons.	local civil contractor	200,000
Laboratory equipment	Local vendor	90,000
Mechanical construction	Local mechanical contractor	120,000
Electrical and control	local E&I contractor	100,000
Total		2760,000

Table 4.4: investment costs

4.4 Drawings and technical drawings

The following drawings have been prepared, see annex E and F:

- two process flow diagrams;
- one plot plan;
- one site plan.

5 Garbage

5.1 Landfill

At this moment ship-generated solid waste (garbage) is accepted in the Port of Bar. The garbage is taken with a lorry to the city dump. There are two uncontrolled dump sites in the port area.

On a very small scale, useful garbage is separated by hand from the rest. The rest of the garbage is taken to landfill. There are no current facilities in the nearby area of the port where processing of waste, such as incineration is performed.

Furthermore, all types of garbage from ships are expected in such quantities that there is no justification for recycling or incineration for garbage from ships only. This would be a feasible option only if facilities for garbage from land based sources would already exist. In Serbia and Montenegro this is not the case.

However, if landfill is the only option, it would be advisable to replace the present uncontrolled landfills with controlled landfills. A modern controlled landfill should include:

- A groundwater monitoring system
- Impervious layer (geo-textile) to prevent leachate entering ground and groundwater
- Drainage system and leachate treatment
- Gas extraction system
- Top cover of sections which are filled up.

5.2 Groundwater monitoring

Evaluation of existing landfills

Landfills percolate micro-contaminations to the groundwater. These micro-contaminations can threaten drinking water storage or river and sea life. The first step is to get insight into the compilation of the micro-contamination plume. Second step is to get insight into the macro-contamination plume, which is much larger than the micro-plume.

A monitoring network is always set up downstream. In a first round of monitoring it is advised to stay close to the landfill, to be sure to get the micro-contamination plume. With these results you can develop a specific monitoring plan for the macro-contamination plume, as its compilation is a result of the natural attenuation process of the micro-contaminations.

Basic principle of contamination by a landfill to the groundwater is shown in the picture below.

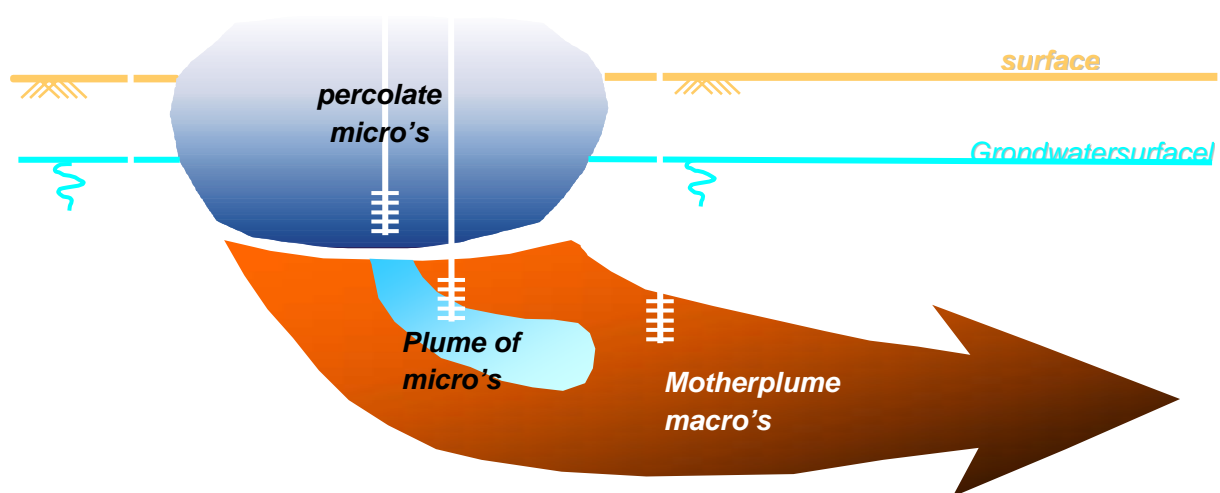

Two types of basic monitoring plans are described, one for uncontrolled landfills and one for controlled landfills.

A. Uncontrolled landfills

For surface areas up to 1 hectare two rows of monitoring wells are placed, with their filter screens up on the first low or impermeable soil layer. The first row of three wells should be placed close to the landfill downstream of the groundwater. The second layer should be placed approximately 20 meters further. By the distance between the wells in the groundwater stream direction it can be determined how pollution concentrations are developing in the plume.

The groundwater should be sampled two times a year during the spring and autumn after a rainy period. The groundwater samples should be taken by professionals who know how to treat the samples for each specific parameter. The parameters which should be analysed are specified in the table 1.1 analyses parameters.

B. Controlled landfills

For controlled landfills the main objective is to check the system is on leakage. Monitoring is not done in two rows but only one. However, the wells are placed in the same way, downstream of the groundwater and close to the landfill. The frequency of sampling is two times a year in the spring and autumn. The frequency can be reduced if there are no contaminations found after approximately 2 years. It is important to get a data set in the beginning to be able to explain fluctuations during the course of monitoring.

The parameters which should be analysed are specified in table 5.1: parameters.

Assessment of the Existing Situation and Needs. Optimum Solutions and Standard designs for Collecting, Treating and Disposing of Ship-Generated Solid and Liquid Wastes in the Port of Bar, Montenegro

Parameters	Uncontrolled landfill	Controlled landfill
Macro parameters	X	
CZV	X	
Ammonium	X	
Nitrogen	X	X
Sulphate	X	
Chloride	X	
pH	X	X
Ec	X	X
Micro parameters		
<i>Metals</i>	X	X
Cd, Cr, Cu, Ni, Pb, Hg, As		
<i>Aromatic Hydrocarbons</i>	X	X
Benzene, Toluene, Ethyl benzene, Xylem, Naphthalene		
<i>Chloride hydrocarbons</i>	X	X
Dichloride methane, trichloride methane, Tetrachloride methane, Trichloride ethene, Tetrachloride ethene, 1,1- and 1,2 dichloride ethane, 1,1,1- and 1,1,2 trichloride ethane		
EOX	X	X
Mineral oil (C10-C40)	X	X
Cyanide	X	X

Table 5.1: parameters

6 Conclusions

The international Convention MARPOL has been ratified by the Government of Serbia and Montenegro.

Based on the needs assessment it is advised that facilities are built for the reception and treatment of oily waste water and also a controlled facility for garbage.

Ship-generated garbage are expected to be collected at the Port of Bar in such quantities that there is no justification for recycling or incineration for garbage from ships only. This would be a feasible option only if facilities for garbage from land based sources would already exist. In Serbia and Montenegro this is not the case. However, if landfill is the only option, it would be advisable to replace the present uncontrolled landfills with controlled landfills.

Based on an assessment on oily waste water, required capacities for reception have been calculated. The assessment however, has been made based on estimated figures, supplied to us by the Port of Bar.

Based on this rough assessment, the treatment capacity of the port reception facility is calculated at 20 m³/h. The reliability of these figures is subject of discussion. To determine actual amounts of waste measurements en registrations need to be carried out at the Port of Bar for at least a year. Based on actual measurements it is possible to evaluate the figures used.

As a part of this study, the requirements for the port reception facility have been defined, in terms of unloading capacities, berths, treatment capacity and design. Also process flow diagrams and layout drawings and functional specifications have been prepared and attached to this report.

Annex A: Terms and definitions

Annex I of MARPOL Convention contains certain regulations and interpretations related to procedures for the retention onboard, treatment, discharge at sea and disposal of oily mixtures generated in the machinery spaces of all ships and the cargo areas of oil tankers.

Annex V, similarly, contains regulations dealing with the storage, disposal and management in general of garbage produced onboard ships. The terms used for the purpose of this Report as well as their definitions which are presented below have been extracted by the following sources:

- MARPOL Convention Annex I Regulations and unified interpretations.
- MARPOL Convention Annex V Regulations.
- IMO Guidelines for the implementation of Annex V of MARPOL Convention. These Guidelines provide information and guidance to assist vessel personnel in complying with the requirements set forth in Annex V and also port and terminal operators in assessing the need for and providing adequate reception facilities for garbage generated onboard different types of ships.
- IMO Guidelines for systems for handling oily wastes in machinery spaces of ships. These guidelines provide guidance in achieving an efficient and effective system for the management of oily bilge-water and oil residues for new buildings and, where applicable and reasonable, for existing ships.

The terms and the definitions used are as follows:

Oil is defined as petroleum in any form including crude oil, fuel oil, sludge, oil refuse and refined products other than petrochemicals.

Oily wastes means oil residues (sludge) and oily bilge-water.

Oil residues (sludge) means:

- separated sludge, which means sludge resulting from purification of fuel and lubricating oil;
- drain and leakage oil, which means oil resulting from drainages and leakages in machinery spaces; and
- exhausted oils, which means exhausted lubricating oil, hydraulic or other hydrocarbon-based liquid which are not suitable for use due to deterioration and contamination.

Oily bilge water means an oil – water mixture containing potentially sea and fresh water, fuel oil, cooling water, leakage and lubricating oil, accumulated either in designated holding tank/s or bilge wells.

Mediterranean Sea area means the Mediterranean Sea including also the gulfs and seas therein with the boundary between the Mediterranean and the Black Sea constituted by the 41^o N parallel and bounded to the west by the straits of Gibraltar at the meridian of 5^o 36' W.

Sludge tanks means:

Assessment of the Existing Situation and Needs. Optimum Solutions and Standard designs for Collecting, Treating and Disposing of Ship-Generated Solid and Liquid Wastes in the Port of Bar, Montenegro

- tanks for separated sludge;
- drain and leakage oil tanks; and
- exhausted oil tanks.

Bilge-water holding tanks mean tanks for oily bilge-water.

Oil sludge incinerators are systems serving for incineration of oil sludge generated on board seagoing ships. Sludge incinerators should be main and auxiliary steam boilers with appropriate oil sludge processing systems, incinerators with appropriate oil sludge processing systems designed for sludge incineration, etc.

Harmful Substance means any substance which, if introduced into the sea, is liable to create hazards to human health, harm living resources and marine life, damage amenities or interfere with other legitimate uses of sea. Harmful substances for which MARPOL Convention has set discharge limits are oil and oily mixtures (Annex I), noxious liquid substances in bulk (Annex II), sewage (Annex IV), garbage (Annex V) and air emissions (Annex VI).

Discharge, in relation to harmful substances or effluents containing such substances, means any release, from a ship and includes any escape, disposal, spilling, leaking, pumping, emitting or emptying which is limited for the purpose of this Report to the discharge of oily bilge water and garbage. Discharge does not include dumping, within the meaning of the London Dumping Convention.

Food wastes are any spoiled or unspoiled victual substances, such as fruits, vegetables, poultry, meat products, food scraps, food particles, and all other materials contaminated by such wastes, generated aboard ship, principally in the galley and dining areas.

Plastic means a solid material which contains as an essential ingredient one or more synthetic organic high polymers and which is formed during either manufacture of the polymer or the fabrication into a finished product by heat and/or pressure. Plastics have material properties ranging from hard and brittle to soft and elastic. Plastics are used for a variety of marine purposes including, but not limited to, packaging (vapor-proof barriers, bottles, containers, liners) ship construction (fiberglass and laminated structures, siding, piping, insulation, flooring, carpets, fabrics, paints and finishes, adhesives, electrical and electronic components), disposable eating utensils and cups, bags, sheeting, floats, fishing nets, strapping bands, rope and line.

Domestic wastes means all types of food wastes and wastes generated in the living spaces on board the ship.

Cargo-associated wastes means all materials which have become wastes as a result of use on board a ship for cargo stowage and handling. Cargo-associated waste includes but is not limited to dunnage, pallets, lining and packing materials, plywood, paper, cardboard, wire, and steel strapping.

Maintenance wastes means materials collected by the engine department and the deck department while maintaining and operating the vessel, such as soot, machinery deposits, scraped paint, deck sweeping, wiping wastes, rags, etc.

Assessment of the Existing Situation and Needs. Optimum Solutions and Standard designs for Collecting, Treating and Disposing of Ship-Generated Solid and Liquid Wastes in the Port of Bar, Montenegro

Operational wastes means all cargo-associated wastes and maintenance wastes, and cargo residues as defined below.

Cargo residues are defined as the remnants of any cargo material on board that cannot be placed in proper cargo holds (loading excess and spillage) or which remains in cargo holds and elsewhere after unloading procedures are completed (unloading residual and spillage).

Oily rags are rags which have been saturated with oil while contaminated rags are those which have been saturated with a substance defined as a harmful substance including oil.

Ash and clinkers from shipboard incinerators and boilers are operational other garbage in the meaning of Annex V respective regulations.

Assessment of the Existing Situation and Needs. Optimum Solutions and Standard designs for Collecting, Treating and Disposing of Ship-Generated Solid and Liquid Wastes in the Port of Bar, Montenegro

Annex B: Port drawing on present situation

Assessment of the Existing Situation and Needs. Optimum Solutions and Standard designs for Collecting, Treating and Disposing of Ship-Generated Solid and Liquid Wastes in the Port of Bar, Montenegro

Annex C: Distribution of ship calls and tonnages in year 2005

Ships in port of Bar for 2005

Type of ship/ Months	January	February	March	April	May	June	July	August	September	October	November	December	TOTAL
Bulk Carrier (Solid bulk)	19	25	27	26	30	22	24	19	17	25	21	23	278
DWT (from-to)	1087 - 3287	2193 - 6063	2092 - 3287	2190 - 3287	2190 - 6285	1871 - 3287	2193 - 3287	2193 - 3287	2193 - 3287	2193 - 3287	2193 - 3287	1951 - 3523	
Bulk Carrier (Liquide bulk)	4	4	6	6	7	7	8	6	7	7	7	6	75
DWT (from-to)	970	942 - 1115	970 - 1032	970 - 1032	942 - 1115	970 - 1032	970 - 6030	970 - 1032	970 - 2360	942 - 1115	942 - 7271	942 - 970	
General Cargoship	10	23	28	31	53	60	36	28	27	34	24	32	386
DWT (from-to)	1239 - 7858	437 - 10829	437 - 9618	466 - 9632	466 - 8739	466 - 13251	466 - 10829	437 - 10829	590 - 3259	466 - 5084	590 - 10829	466 - 12522	
Passenger ship	12	11	12	7	12	2	9	15	13	16	5	1	115
DWT (from-to)	8697	8697	8697	8697	8697	8697	1260 - 8697	108 - 8697	209 - 8697	103 - 8697	350 - 8697	310	
Tanker	4	4	7	6	6	6	10	10	8	8	7	5	81
DWT (from-to)	4471 - 4969	1533 - 9860	938 - 22184	1848 - 4499	2117 - 22422	933 - 8549	945 - 17199	933 - 15064	1471 - 11088	3335	3726	922 - 15064	
Friggo ship	4	1		1	6	3	4	2	4	1	1	3	30
DWT (from-to)	6419 - 12111	6562		3999	9618 - 10829	9869 - 10829	10842 - 10842	9801 - 10829	7741 - 10829	10842	10829	9981 - 12111	
Container ship			2	1				1				1	5
DWT (from-to)			445 - 5261	5261				1042				5424	
RO-RO ship	2	4	2	7	5	15	20	19	10	6	19	18	127
DWT (from-to)	8904	8904 - 12110	3979 - 12110	6918 - 12110	8904 - 12110	6918 - 8904	6650 - 8904	6650 - 8904	6918 - 8904	5191 - 8904	97 - 132	5191 - 8904	
Combination carrier												2	2
DWT (from-to)												382	
Total no. of ships for 2005	55	72	84	85	119	113	111	100	86	97	84	91	1097

Assessment of the Existing Situation and Needs. Optimum Solutions and Standard designs for Collecting, Treating and Disposing of Ship-Generated Solid and Liquid Wastes in the Port of Bar, Montenegro

Annex E: Process flow diagrams

Assessment of the Existing Situation and Needs. Optimum Solutions and Standard designs for Collecting, Treating and Disposing of Ship-Generated Solid and Liquid Wastes in the Port of Bar, Montenegro

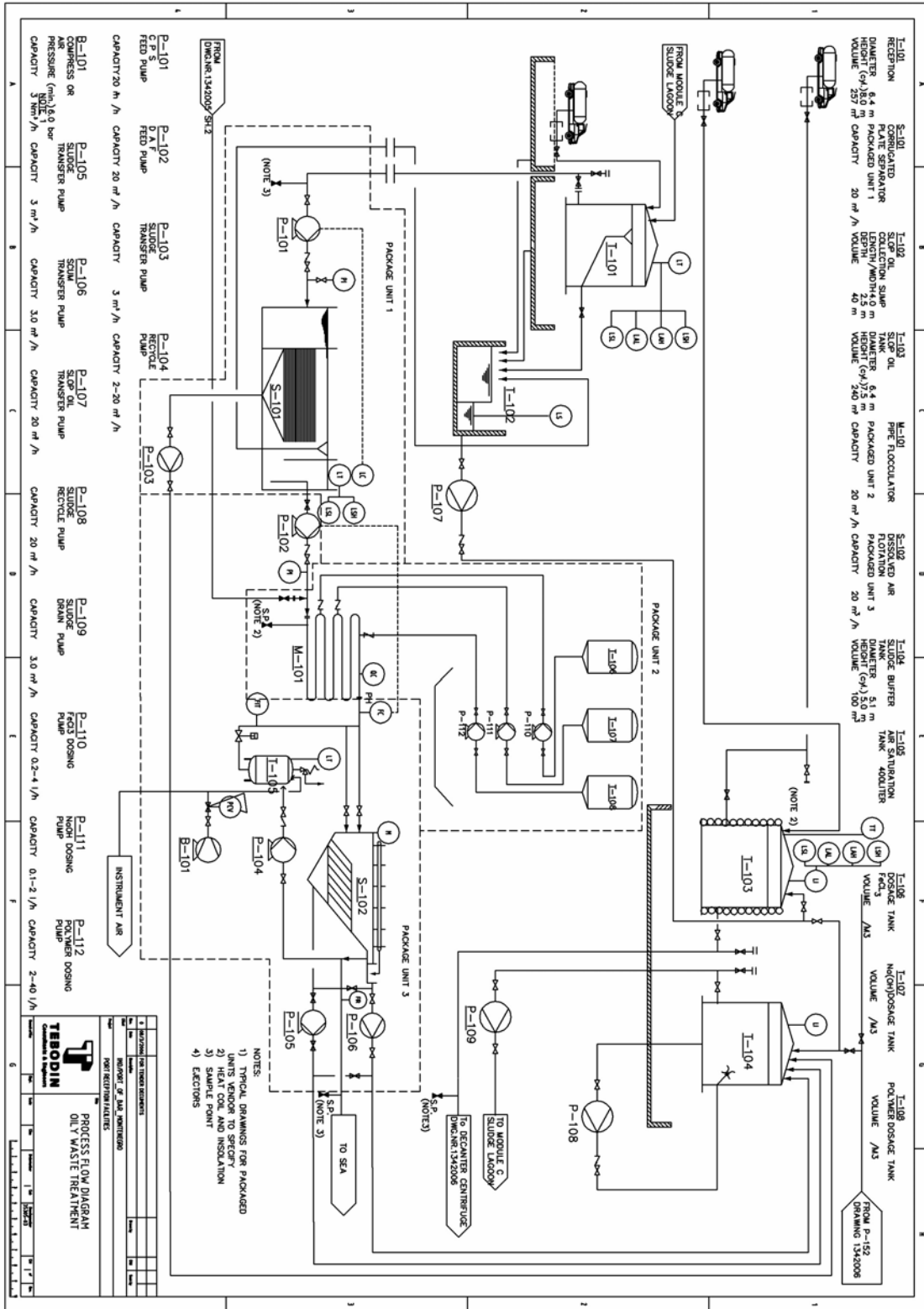

Assessment of the Existing Situation and Needs. Optimum Solutions and Standard designs for Collecting, Treating and Disposing of Ship-Generated Solid and Liquid Wastes in the Port of Bar, Montenegro

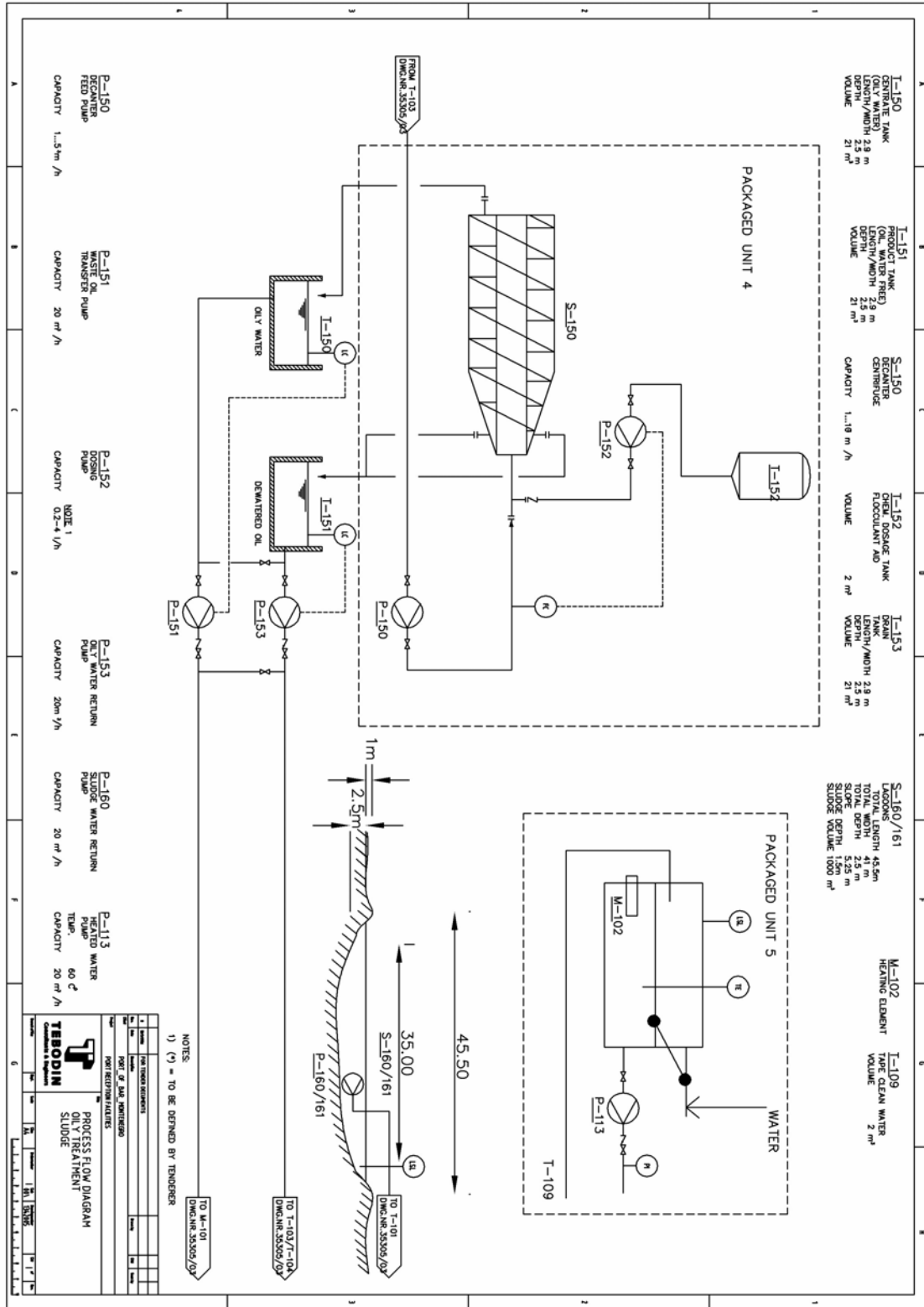

Assessment of the Existing Situation and Needs. Optimum Solutions and Standard designs for Collecting, Treating and Disposing of Ship-Generated Solid and Liquid Wastes in the Port of Bar, Montenegro

Annex F: Lay-out and site plan

Assessment of the Existing Situation and Needs. Optimum Solutions and Standard designs for Collecting, Treating and Disposing of Ship-Generated Solid and Liquid Wastes in the Port of Bar, Montenegro

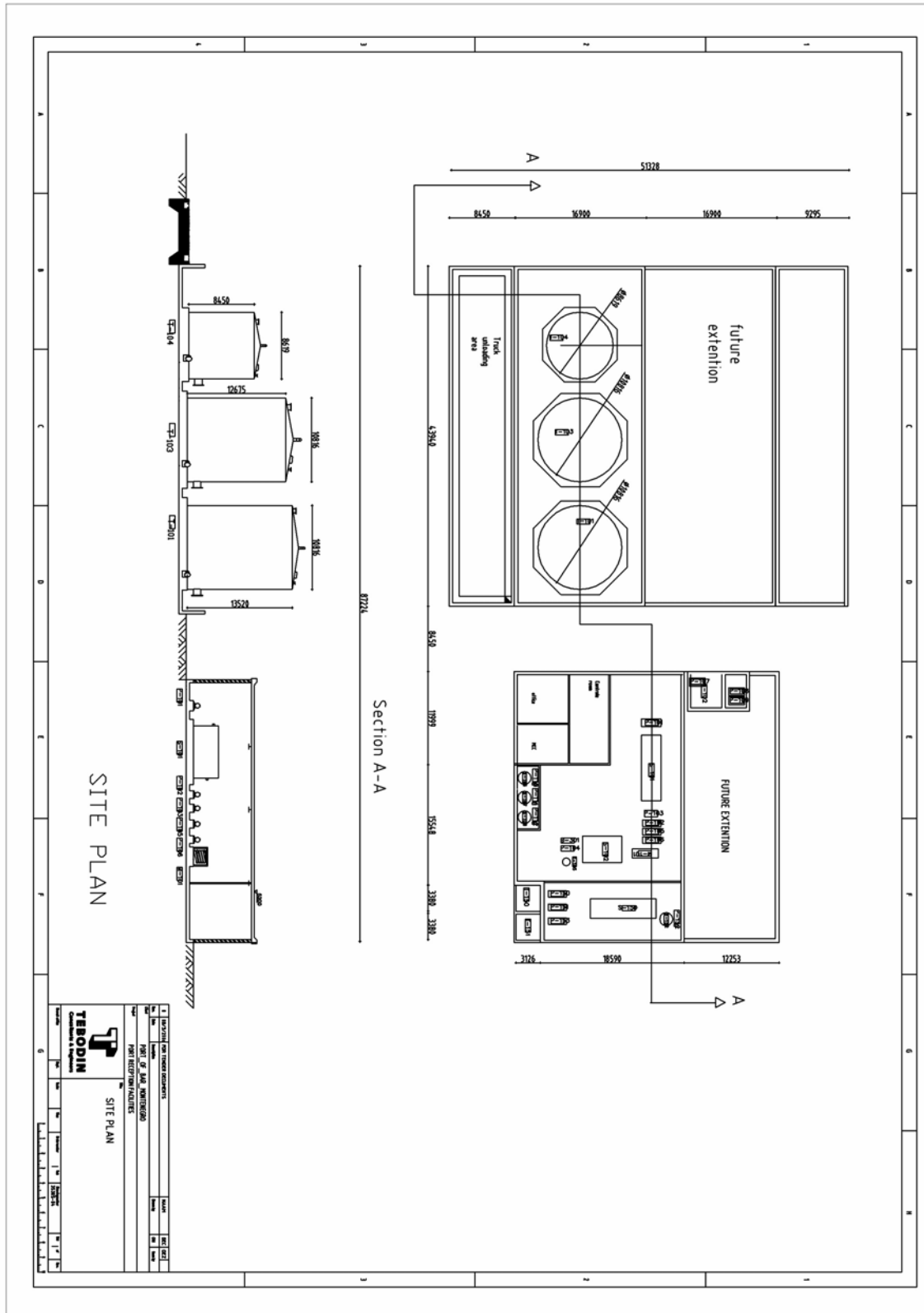

Assessment of the Existing Situation and Needs. Optimum Solutions and Standard designs for Collecting, Treating and Disposing of Ship-Generated Solid and Liquid Wastes in the Port of Bar, Montenegro

Annex G: Pictures of Hemosan Oily water treatment facility in Zelenika



Assessment of the Existing Situation and Needs. Optimum Solutions and Standard designs for Collecting, Treating and Disposing of Ship-Generated Solid and Liquid Wastes in the Port of Bar, Montenegro



Assessment of the Existing Situation and Needs. Optimum Solutions and Standard designs for Collecting, Treating and Disposing of Ship-Generated Solid and Liquid Wastes in the Port of Bar, Montenegro



Assessment of the Existing Situation and Needs. Optimum Solutions and Standard designs for Collecting, Treating and Disposing of Ship-Generated Solid and Liquid Wastes in the Port of Bar, Montenegro

Annex H: Functional Specification

Functional Specification for Oily Waste Treatment Port Reception Facility in Bar, Montenegro

0	April2006	For Quotation/Comments	
rev.	date	description / issued for	author ckd.
	client:	REMPEC	
	project:	Port Reception Facility, Bar, Montenegro	
	title:	Functional Specification Oily Waste Treatment and Port Reception Facility	
office: Velsen		Order: 35305	document: 0 rev.: 0 sheet: 1 of: 48

Table of contents	page
Definitions	5
1 General Requirements	7
1.1 Introduction	7
1.2 Order of precedence	7
1.3 Required information	7
1.4 Responsibilities for Tenderer	7
1.5 Responsibilities for Vendors	7
1.6 Exceptions to Specifications	8
1.7 Alternative design	8
1.8 Site information	8
2 Description of the Works	10
2.1 General	10
2.2 Process description	10
2.3 Packaged units and tanks	12
2.4 Process design basis	13
2.4.1 Oily waste characteristics	13
2.4.2 Typical composition	13
2.4.3 Removal efficiencies	14
2.4.4 Process guarantees	14
2.5 Vendor scope of supply / Packaged Units	15
2.5.1 Tanks Scope of supply	17
2.6 Lagoons	18
2.7 Lagoon design	19
3 General Specifications	22
3.1 Responsibility	22
3.2 Detailed Design	22
3.3 Standards and Regulations	22
3.4 Battery limits	23
3.4.1 Basic interface connections	23
3.4.2 Battery Limits Tenderer	23
3.4.3 Battery Limits Packaged units	24
3.4.4 Details Battery Limits	24
3.5 Documentation	24
3.5.1 Manufacturing report	24
3.5.2 Documents for regulatory approvals by relevant authorities	25
3.5.3 As-built drawings	25
3.5.4 Manuals	25
3.5.5 Submittal, review and approval of documents	26
3.5.6 Other instructions for documents	26
3.6 Coordination and Inspections	27
3.7 Testing, inspections and guarantees	27
3.7.1 Quality Requirements, Testing	27

3.7.2	Guarantees	28
3.7.3	Inspections	28
3.7.4	Performance testing	28
3.8	Spare parts	28
3.9	Commissioning and Take Over	29
3.10	Training for operation and maintenance	29
3.10.1	General	29
3.10.2	Training Programme	29
3.10.3	Contractor's Training Personnel	29
3.10.4	Safety Training	30
3.10.5	Language for Training	30
4	Specification for Mechanical Works	31
4.1	Service life	31
4.2	General Requirements	31
4.3	Tanks	31
4.4	Erection of tanks	31
4.5	Pumps	32
4.6	Pipes	33
4.7	Valves	34
4.8	Corrosion Protection, Painting	35
4.9	Noise requirements	36
4.10	Maintenance	36
5	Specification for Civil Works	37
5.1	General Requirements	37
5.2	Civil works scope	37
5.3	Earthworks	37
5.3.1	Levelling and roads	37
5.3.2	Excavations	37
5.3.3	Supporting the Excavations	37
5.4	Building	38
5.5	Concrete and reinforcements	38
5.5.1	Water Proof Concrete	38
5.5.2	Reinforcement	38
5.5.3	Water retaining structures	39
5.5.4	Finishing of Concrete Surfaces	39
5.5.5	Brick and concrete block work	39
5.6	Roofing	40
6	Specification for Electrical Works	41
6.1	General Requirements	41
6.2	Electrical equipment	41
6.2.1	Switchgears	41
6.2.2	Electric Motors	42
6.2.3	Electric Actuators	43
6.3	Cables	43

6.4	Lighting	44
6.5	Earthing	44
7	Specification for Instrumentation and Control	45
7.1	General Requirements	45
7.2	Measuring Equipment	45
7.2.1	Electromagnetic flow meter	45
7.2.2	Ultrasonic flow meter	45
7.2.3	Ultrasonic level meter	46
7.2.4	Piezoresistive pressure level meter	46
7.2.5	Level switches	46
7.2.6	IR Spectrometer	46
7.2.7	Water in oil	47
7.2.8	Design	47
7.3	Automation Works	48

Definitions

The following notes and expressions in this specification shall have the meaning hereby assigned to them for the purpose of this request except where the context otherwise requires:

'Government' means the Government of Montenegro

'Owner' means the competent authority issuing the Tender Documents for these works.

'Purchaser' means the organisation assigned by the Owner issuing the Tender Documents for these works.

'Works' and **'Permanent Works'** means the port reception facility to be provided and all work to be executed in accordance with the Contract including, if applicable, the design, engineering, manufacture, delivery, supply, erection, construction, supervision, commissioning, start-up and performance testing. In case of a private investment or a Built Own Operate (Transfer), this definition shall include investment, finance, operation and maintenance.

'Temporary Works' means all temporary works of every kind required in or about the execution of the Works.

'Specification' means the technical specification according to which the works are to be executed referred to in the Contract Documents and any other specification agreed thereon.

'Tenderer' means the Company who delivers a proposal on behalf of this invitation for tendering.

'Contractor' means the person or persons, firm or company whose proposal has been accepted by the Owner and includes the Tenderer's authorised representatives, successors and permitted assigns.

'Sub-Contractor' means any person or persons, firm or company entering into an agreement with the Contractor for performance of work under this Assignment.

'Vendor' means the supplier of the packaged units or other equipment.

'Terms of Reference' (ToR) means the statement issued by the Owner giving the definition of its requirements and objectives of the services, including, where applicable, the methods and means to be used and/or results.

'Schedule' means the Schedule or Schedules in which the Works are described for the purpose of evaluating the items of the Works to be executed under the Assignment by the Contractor.

'Site' means the land and other places, on, under, in or through which the Works are to be executed or carried out and any other lands or places provided by the Owner for the



client:	REMPEC
project:	Port Reception Facility, Bar, Montenegro
title:	Functional Specification Oily Waste Treatment and Port Reception Facility

purposes of the assignment together with such other places as may be specifically designated in the Contract as forming part of the Site.

Words implying persons or parties shall include firms and corporations. Words implying the singular only also include the plural and vice versa where the context requires.



client:	REMPEC
project:	Port Reception Facility, Bar, Montenegro
title:	Functional Specification Oily Waste Treatment and Port Reception Facility

office: Velsen	Order: 35305	document: 0	rev.: 0	sheet: 6	of: 48
----------------	--------------	-------------	---------	----------	--------

1 General Requirements

1.1 Introduction

This Technical Specification represents the functional specification of the required facilities in the relevant ports consisting of packaged units and one or more contractors for the civil, mechanical, electrical and control works.

This Technical Specification is issued for sending request for quotations to Vendors and call for tenders to Tenderers. As such as back to back agreement between Tenderer and Vendor is assumed.

1.2 Order of precedence

In the event of conflict between the requirements of this specification, data sheets or reference design documents, the priority of order shall be as follows:

- national Legal and Statutory Requirements;
- contract or Purchase Order with General Conditions of Supply;
- data sheets;
- this specification;
- other referenced documents.

Any query shall be brought to Purchasers attention prior to proceeding with the design and / or fabrication.

1.3 Required information

With the quotation the Tenderer or Vendor shall supply all information in this specification and the data sheets, which are denoted with an asterisk (*).

1.4 Responsibilities for Tenderer

The Tenderer shall execute the Work, in accordance with but not limited to this Specification, necessary for a safe and reliable operation.

In order to fully understand the Specification, the Tenderer is expected and required to make the necessary inquiries.

The Tenderer shall be responsible for ensuring that the equipment offered meets all relevant local and statutory requirements.

1.5 Responsibilities for Vendors

The Vendor shall supply fully operational units, fit for purpose, including items which are not specifically mentioned in the specifications but which are necessary for a safe and reliable operation.



client:	REMPEC
project:	Port Reception Facility, Bar, Montenegro
title:	Functional Specification Oily Waste Treatment and Port Reception Facility

The Vendor shall be fully responsible for each complete package including all equipment supplied through him by other Suppliers. He shall also ensure that all such equipment can be properly integrated into each whole installation in order to meet the applied specifications. The Vendor's responsibilities shall include design, supply of material, fabrication, control of suppliers, dimensional compatibility, authority approvals, inspection, testing, installation, guarantee, quality assurance and control. Responsibilities shall also include the provision of all data needed for the design of support structures or foundations. The activities of the Purchaser are strictly limited to the review of the documents, including the proposed construction details, as supplied by the Vendor.

Approval is required from the Purchaser in the event of sub-contract by the Vendor. Upon completion of manufacture the Vendor shall be responsible for packing, protection and delivery to Bar, Montenegro.

The Vendor shall be responsible for ensuring that all of the defined/referenced specifications herein are in his possession.

The Vendor shall be responsible for ensuring that the equipment offered meets all relevant local and statutory requirements.

Vendor shall quote the prices for the five packaged units whereas it is the intention of the Purchaser to make a packaged deal for multiple packaged units to minimize interfaces and to comply with process guarantees.

1.6 Exceptions to Specifications

The Tenderer/Vendor will issue a document of conformity.

In this document, the Vendor must clearly list and motivate all proposed deviations/exceptions, if any, from this or any other applicable document as listed in the requisition with reference to the applicable document and paragraph number.

If no document of conformity is submitted with the quotation, the Purchaser shall assume that the Vendor has accepted all documents.

1.7 Alternative design

On the condition that a Tender is submitted in accordance with the above, the Tenderer may submit for consideration an alternative Tender incorporating an alternative technical proposal. The alternative proposal must be submitted as an alternative Tender and the departures from the specified requirements must be clearly stated. The Tenderer shall also state his reasons for proposing such deviations. The departures shall be individually priced which shall enable the Owner at his option to adjust the Tender price where he considers any particular departure to be acceptable.

1.8 Site information

The Tenderer should inspect the Site and its surroundings and have to satisfy himself completely before submitting his Tender as to the nature of the ground and sub-soil, the hydrological and climatic conditions, the form and nature of the site, the quantities and nature of the Work and materials necessary for completion of the Works and the means of access to

	client:	REMPEC			
	project:	Port Reception Facility, Bar, Montenegro			
	title:	Functional Specification Oily Waste Treatment and Port Reception Facility			
office: Velsen	Order: 35305	document: 0	rev.: 0	sheet: 8	of: 48

the Site by land and sea, to have himself obtained all necessary information as to risks, contingencies and other circumstances which may influence or affect his Tender. The site location will be clarified in the Instruction to Tenders by Owner.



client:	REMPEC				
project:	Port Reception Facility, Bar, Montenegro				
title:	Functional Specification Oily Waste Treatment and Port Reception Facility				
office: Velsen	Order: 35305	document: 0	rev.: 0	sheet: 9	of: 48

2 Description of the Works

2.1 General

The scope of services and supply shall comprise, but is not limited to, the following:

- the detailed design, construction, supply and installation, process start-up and testing for operation parameters and handing over to the Owner a complete, reliable, safe and operational system including all items, services and documents except those specifically indicated as 'Exclusion' in this Specification;
- a complete detailed description of each part of the equipment offered;
- a description of the design principles and the materials of construction;
- quality and safety objectives and operational conditions;
- the method of operation;
- the relevant standards applicable to the design;
- listing of applicable international and local law pertaining the complexity of the plant and environmental conditions;
- a complete set of performance data and characteristics;
- a computation of equipment capacities and sizing where required;
- a list of particular process guarantees;
- a complete set of drawings;
- a training schedule for the Owners personnel in operation and maintenance;
- a time schedule for completion.

2.2 Process description

The works comprise three elementary building blocks:

- module A: oily water reception and treatment facilities;
- module B: slop oil dewatering facilities;
- module C: oily sludge dewatering facilities.

A simplified diagram is shown below. The modules and the description in this section are only for information and do not represent the Work breakdown.

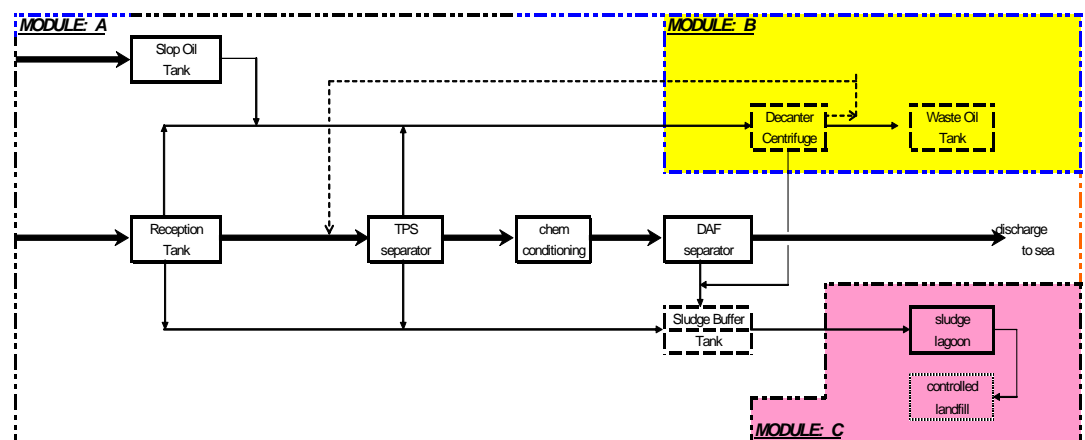

Module A: oily water treatment facilities

Oily wastes with high water content from bilge water and slop oil are transferred to a reception tank, equipped with a skimmer to remove the bulk of free oil. After sufficient residence time, the water fraction shall be withdrawn and pumped to a tilted or corrugated plate separator (TPS or equal) to remove the remaining free oil. The design capacity is 20 m³/h.

The second treatment step is coagulation-flocculation followed by flotation (DAF or equal). Metering pumps add the required chemicals to the waste water, air saturated recycle water will be added into a DAF-unit, where all the flocculated oil and solids are separated.

A slop oil holding tank shall be provided for collecting the free oil separated in the holding tank and the TPS. Also slops and other oily residues (with high oil content) are pumped into this tank. Water that settles in this tank shall intermittently be drained and led to the TPS.

A sludge buffer tank shall be provided for holding the sludge's collected in the oil/water separator and the DAF unit. The treated effluent shall contain less than 8 ppm oil and shall discharged to a sewer or sea.

Since the works shall be designed for heavy duty concerning the mineral oil contamination, it is strongly advised to install a two step oil removal treatment. In order to minimise the sludge production the dosage of iron salts and flocculant aid should be as low as reasonably achievable. The Tenderer shall specify and guarantee the average and the maximum chemicals consumption.

It might be essential to conduct a number of trail runs on laboratory scale prior to the ultimate design in order to select the appropriate dosing agents for the flotation treatment.

A lamella separator shall be used to increase the effective separation surface of the plant so that its maximum admissible hydraulic load is higher than that of traditional plants of equal dimensions. Surface scrapers shall remove the scum while the settled solids shall be discharged by pump or by gravity.

The clear water flows behind the submerged scum board into the clear water chamber from where it exits over a height-adjustable weir into the clear water outlet. The water level in the flotation tank and consequently the immersion depth of the scraper bars shall be adjustable by means of this weir.

A partial flow of clarified water shall be reused as pressure water. The air (over)pressure for dissolving purpose should be 6 bar minimum. The micro bubbles that are produced on release of pressure should preferably have a diameter of 40-70 µm.

The required rejection rates and effluent concentrations are presented in section 4.2.2, table 4. These figures must be guaranteed at a chemical consumption to be specified by the Vendor.



client:	REMPEC
project:	Port Reception Facility, Bar, Montenegro
title:	Functional Specification Oily Waste Treatment and Port Reception Facility

office: Velsen	Order: 35305	document: 0	rev.: 0	sheet: 11	of: 48
----------------	--------------	-------------	---------	-----------	--------

Module B: slop oil treatment facilities

The waste oil needs to meet specifications for processing and hence a centrifuge shall be applied. Water which is separated will be re-routed to the TPS; the solids will be transferred to the sludge buffer tank and ultimately stored in a landfill. The oil, free of solids and water is stored in a buffer tank ready for further use.

For the separation of oil, water and mud a three phase machine might be applicable. However for the reliability of operation a two phase machine might be preferable. In that case the centrate will contain water and mud which can easily be separated in the flotation unit. The vendor is requested to advice the best option. The Vendor shall compute the remaining water in the oil phase.

Module C: residual sludge treatment facilities

Dewatering of sludge, separated in the modules A and B, shall take place in a lagoon from where the sediments shall be sent to a controlled landfill for final disposal.

2.3 Packaged units and tanks

The selected treatment technologies as main units are as follows.

Table 1: Vendor packages

Units	Tendering
1 Reception tank	local fabrication
1 Slop oil tank	
1 Sludge buffer tank	
1 Corrugated Plate Interceptor	packaged unit 1
1 Flocculation and chemical dosing	packaged unit 2
1 Flotation unit	packaged unit 3
1 Decanter Centrifuge	packaged unit 4
1 Water heating unit	packaged unit 5
2 Lagoons	Civil contractor

The packaged units are to be supplied with and not limited to all piping, pumps, electrical components, instruments and control. The Vendor is encouraged to quote for more packaged units and preferentially for all. Capacities and preliminary sizes of the different units are shown on the drawings.

The three tanks, to be constructed in SS316L, are also considered as one package. The lagoons will be part of the civil contractor scope.

The port reception facility shall be designed to allow for future extension with three similar tanks and one additional line with treatment units as indicated on the drawings. Therefore, necessary tie-ins and spacing shall be provided.



client: REMPEC
project: Port Reception Facility, Bar, Montenegro
title: Functional Specification Oily Waste Treatment and Port Reception Facility

2.4 Process design basis

2.4.1 Oily waste characteristics

In this Specification, the oily waste originates from bilge water and slop (residual sludge) oil from ships.

- oil residues (sludge) or slop oil mean:
 - separated sludge, which means sludge resulting from purification of fuel and lubricating oil;
 - drain and leakage oil, which means oil resulting from drainages and leakages in machinery spaces; and
 - exhausted oils, which means exhausted lubricating oil, hydraulic or other hydrocarbon-based liquid which are not suitable for use due to deterioration and contamination.
- oily bilge water means an oil – water mixture potentially containing sea and fresh water, fuel oil, cooling water, leakage and lubricating oil, accumulated either in designated holding tank/s or bilge wells:
- oily wastes mean oil residues (sludge) and oily bilge-water;
- oily mixture means a mixture of aforementioned oil components;
- Hydrocarbons mean the light fraction like aromatic compounds (BTEX), more or less miscible with water;
- Oil and grease mean the middle to heavy oil fraction.

The Design of the Port Reception Facility Modules is based on the physical and chemical properties of waste oil which can have varying properties with specific gravities between 0.85 up to 1.15 [kg/dm³]. The waste oil may contain sulphur or nitrogen compounds that change their characteristics. Small concentrations of metals may also be present. The oil - water mixtures are present partly as free and emulsified oil have varying characteristics depending on their density and appearance (free/emulsified).

2.4.2 Typical composition

Table 2 summarizes the main characteristics of waste oil that typically will be expected at delivery to the port reception facility.

Table 2: Typical composition of oily wastes

	Composition				Type of oil
	Oil		Water	Solids	
	[ppm]	[%]	[%]	[%]	
Dirty ballast	100	0.01	Approx. 100	Traces	Free (mainly crude)
Bilge water untreated	20,000	2	98	Traces	Free and emulsified oil (mixtures)
Tank washings	30,000	3	97	Traces	Free and emulsified oil (mixtures)
Slops/oily residues	300,000	30	65	5	Free and emulsified oil (mixtures)



client: REMPEC
 project: Port Reception Facility, Bar, Montenegro
 title: Functional Specification Oily Waste Treatment and Port Reception Facility

2.4.3 Removal efficiencies

The influent oil content of the oily water intake as presented in table 2 is very conservatively estimated. The degradation efficiencies shown in table 3 and 4 are regarded to be achievable with the selected treatment technologies. Tenderer shall guarantee the degradation rates. These figures will become subject of the Contract Documents.

Table 3: Percentage of degradation required

Pollutant	Required Degradation			Matter
	API/CPS	DAF	Over-all	
Suspended Solids	80%	90%	98.0%	SS
Floating Particles	50%	99.9%	99.7%	Float
pH ¹⁾	(*)	(*)	(*)	pH
Oil&Grease	85%	>99.5%	>99.5%	Oil/Grease
Hydrocarbons	20%	90%	92.0%	HC

- 1) Tenderer is requested to consider the need of pH correction with his system prior to effluent discharge.

Table 5: Effluent quality of slop oil after dewatering

Pollutant	Max. Influent [mg/l]	Achievable Degradation ²⁾		Circa Effluent [mg/l]
		2-phase decanter	3-phase decanter	
Suspended Solids	50,000	(*)	(*)	(*)
Oil	300,000	(*)	(*)	(*)
Water	650,000	(*)	(*)	(*)

- 2) Tenderer shall guarantee the achievable rejection rates and effluent concentrations at chemical Consumptions (to be specified by Tenderer). These figures will become subject of the Contract Documents.

2.4.4 Process guarantees

Above the degradation rates, the Vendor shall guarantee the effluent quality at the discharge of the port reception facility as stated in the table 6.

Table 6: Effluent limits

Parameter	Units	Effluent
Total Suspended Solids	mg/l	20.0
Turbidity	NTU	10
pH ¹⁾	-	6...9
Oil&Fats&Grease ³⁾	mg/l	< 8.0

- 3) Oil content by means of infrared spectrophotometer.

2.5 Vendor scope of supply / Packaged Units

The vendor scope includes but is not limited to the supply of materials, certificates and services as follows.

Table 7: Vendor scope package unit 1

packaged unit 1	Supply of materials 1 Corrugated Plate Interceptor unit or equivalent
1.	1 SS316 L tank (design flow 20 m3/h)
2.	1 plate interceptor package
3.	1 feed pump 20 m3/h P-101
4.	1 sludge transfer pump 3 m3/h P-103
5.	1 level transmitter controller

Table 8: Vendor scope package unit 2

packaged unit 2	Supply of materials 1 Flocculation and chemical dosing
6.	1 static mixer (design flow 20 m3/h) M-101
7.	1 pH-controller
8.	1 FeCl3 dosing pump P-110
9.	1 FeCl3 dosage tank 1 m3 T-106
10.	1 NaOH dosing pump P-111
11.	1 NaOH dosage tank 1 m3 T-107
12.	1 polymer dosing pump P-112
13.	1 polymer dosage tank 1 m3 T-108

Table 9: Vendor scope package unit 3

packaged unit 3	Supply of materials 1 Flotation unit
14.	1 SS316L Flotation tank (design flow 20 m3/h) S-102
15.	1 Air compressor B-101
16.	1 compressed air vessel T-105
17.	1 Feed pump P-102
18.	1 Recycle pump P-104
19.	1 Sludge transfer pump P-105
20.	1 Scum transfer pump P-106
21.	1 Flow controller
22.	2 Flow transmitters
23.	1 Pressure control valve
24.	1 Safety valve

Table 10: Vendor scope package unit 4

packaged unit 4	Supply of materials 1 Decanter Centrifuge unit
25.	1 Decanter centrifuge (bowl type) S-150

26.	1 Decanter feed pump P-150
27.	1 Flocculant dosing pump P-152
28.	1 Flocculant dosage tank 1 m3 T-152

Table 11: Vendor scope package unit 5

packaged unit 5	Supply of materials
	1 Heating water unit
29.	1 Tank clean water T-109 20 m3
30.	1 Level switch
31.	1 Heating element (60 degrees Celcius)
32.	1 Heated water pump 20 m3/h
33.	
34.	Other equipment
35.	1 slop oil transfer pump 20 m3/h P-107
36.	1 Sludge recycle pump 20 m3/h P-108
37.	1 Waste oil transfer pump 10 m3/h
38.	1 Oily water return pump 10 m3/h
39.	2 Sludge water return pumps 5 m3/h
40.	1 Temperature transmitter for T-103
41.	1 IR-spectrophotometer
42.	1 water in oil analyzer
43.	3 Level transmitters for T-101/103/104
44.	2 level controllers for P-151/P-153
45.	2 level switches for lagoons
46.	1 level switch for T-102

Table 12: Vendor scope for each package unit

47.	Piping
48.	Interconnection ducting and piping including pipe supports
49.	Utility piping including design, testing, installation.
50.	Instrumentation
51.	Instrumentation and control for the package
52.	All instrumentation cabling on the skid to junction boxes at battery limit.
53.	Local control cabinet
54.	Electrical
55.	All electrical cabling on the skids to junction boxes at battery limit
56.	Electric drivers and motor (soft)starters.
57.	Power distribution / remote control cabinet.
58.	All required internals and packing materials including installation
59.	All required provisions for air induced vibrations
60.	Piping, ducting and expansion bellows up to the battery limit. Including pipe supports
61.	If applicable, all required stairs, ladders, platforms, stairways, gangways, including handrailing, safety cages,
62.	All required clips , such as pipe support clips, ladder clips, platform clips,

	cable trays,
63.	All required drains, flanged and valves
64.	All required components and other devices at the Battery Limits, such as pressure reducers, safety valves, filters, drains for all utilities
65.	Valves and drives for valves
66.	Field instruments
67.	Local panel with all instrumentation and controls for the system.
68.	If applicable, earthing system.
69.	All nameplates and identification plates including brackets (authority and manufacturer)
70.	Surface preparation and painting
71.	All other components required for a good functional unit.
72.	Factory Acceptance Testing (FAT) of all components.
73.	Packing, protection and marking suitable for transportation and short term storage prior to installation
74.	Delivery to Jobsite.including all required provisions for transport and handling
75.	Vendor long distance input to HAZOP meetings
76.	Consumables (chemicals and first charge of lubricants etc)
77.	Supply of chemicals
78.	Supply of first fill of lubricants and filter elements.
79.	Installation at site
80.	Commissioning and start-up assistance.
81.	Site Acceptance Testing (SAT).
82.	Limited training for plant operators and maintenance personnel
83.	Guarantees.
84.	Authority Approval
85.	Authority approval, including all handling and inspection costs
86.	Certification (PED, ATEX, Machinery directive, etc)
87.	Documentation
88.	The preparation of all necessary engineering documents as per Vendor Documents Required as listed in the requisition

All electro-mechanical equipment and instrumentation, which is not part of the packaged units 1 to 4 shall be included in Package 5.

2.5.1 Tanks Scope of supply

Tanks shall be designed as aboveground storage tank with fixed roof for class K3 combustible liquid. Tank foundation shall be stable and capable of supporting the total weight of the tank and its contents. Tank material shall be SS 316L. The tank system's exterior and interior must be protected with an appropriate coating or paint.

Tanks shall generally be equipped with breather valves, flame arrestor, fill port, suction device with expansion relief valve and drainage facilities. Design and Performance Standards shall be conform API 200 or equivalent. Tanks shall have two manholes, walkway and stairs where appropriate. Railings shall be in accordance with the safety requirements. Tanks must



client:	REMPEC
project:	Port Reception Facility, Bar, Montenegro
title:	Functional Specification Oily Waste Treatment and Port Reception Facility

have a local filling indication and shall be labelled or marked so that the filling grade is visible.

The tank sizings and main characteristics for the reception, slop oil and sludge buffer tank are as follows. The weight and wall thickness are indicative and shall be calculated by Vendor.

Tanks shall be located in a hydrocarbon resistant dike or a concrete bund wall which is capable to contain 110% of the tank volume.

2.6 Lagoons

Lagoons should be located at least 500 m downwind from the nearest housing area and away from any likely area of future expansion. Otherwise odour release is most likely to become a problem even for a well designed and properly maintained system.

There should be vehicular access to and around the lagoons and, so as to minimise earthworks, the site should be flat or gently sloping.

Geotechnical aspects of lagoon design are important. The principal objectives of a geotechnical investigation are to ensure correct embankment design and to determine whether the soil is sufficiently permeable to require the lagoon to be lined. The maximum height of the groundwater table should be determined, and the following properties of the soil at the proposed lagoon location must be measured:

- particle size distribution;
- maximum dry density and optimum moisture content (modified Proctor test);
- layer thickness (must exceed 2.0 m);
- Atterberg limits;
- organic content;
- coefficient of permeability.

At least four soil samples should be taken per lagoon, and they should be as undisturbed as possible. The samples should be representative of the soil profile to a depth 1 m greater than the envisaged lagoon depth.

The Tenderer shall be aware that the local circumstances can influence the lagoon dimension. The Tenderer must calculate embankments, lining, inlet and outlet structures. It must be decided, which security equipment (fencing, lifesavers and notices) is generally required, and which operator facilities must be provided.

The construction and operation of the lagoon shall include a high level of environmental protection measures, which have been determined on the basis of the assessment of potential impacts and mitigation measures. Environmental protection shall be a key factor in the design and operation of the site.

The environmental protection measures are inherent in the design and operations. An important aspect of the work will be to ensure that the high standards are passed to any



client:	REMPEC
project:	Port Reception Facility, Bar, Montenegro
title:	Functional Specification Oily Waste Treatment and Port Reception Facility

future operator. This will include setting up an accessible training programme.

In addition to following good practice, this high level of regard for the environment will also minimise future liability for damages or clean-up costs. This will be especially important if a commercial operator and its subsequent customers are to be attracted to the site.

A Health and Safety Plan shall be finalised in cooperation with the Contractor and shall contain the details of the emergency response plan. A limited number of potential emergency situations are envisaged for project operations. These are:

- spillage of waste outside the lagoon;
- fire in the offices or on board vehicles;
- accidents involving moving vehicles.

These emergencies must be anticipated and, as much as possible, prevented by operational procedures.

2.7 Lagoon design

The lagoon shall be designed and constructed for the disposal of oil contaminated sludge arising from the port reception facility. Oily sludge of different kind shall be collected in the Sludge Buffer Tank from where it will be transferred to the lagoon for further dewatering.

In the lagoon the water content of the sludge will be reduced by evaporation, dried sludge will pile up and must be removed as hazardous waste to the local landfill.

It must be emphasized that the ultimate dimensions of the lagoon might be influenced by local circumstances. An indication of the required lagoon capacity can be seen in table 16.

As shown in Figure 1, the Tenderer shall base his calculation of the ultimate lagoon dimensions on a mid-depth area. The top and the bottom dimensions shall be calculated as demonstrated in figure 1 to be corrected for the slope of the embankment.

Figure 1: Principal lagoon dimensions

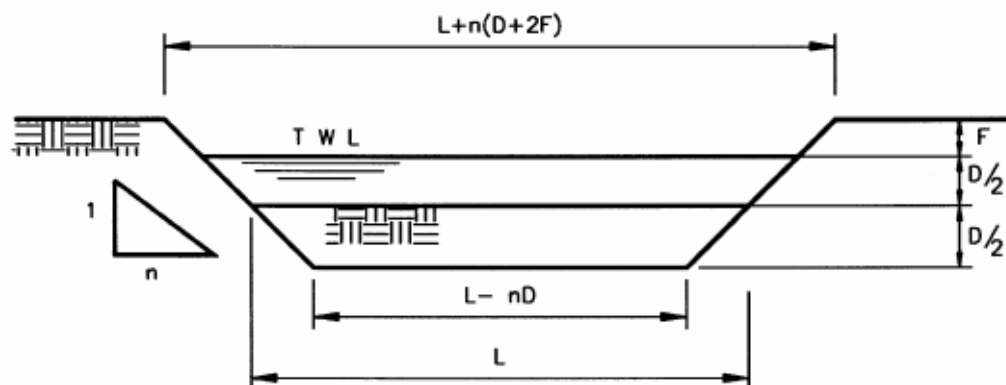

Table 16: Approximate lagoon dimensions

Approximate lagoon dimensions			
Width	W	10	m
Length	L	35	m
Depth	D	1.5	m
Freeboard	F	1	m
Slope	n	3	-

The minimum freeboard (F) that should be provided shall be decided on the basis of preventing waves, induced by the wind, from overtopping the embankment. For small lagoons a minimum of 0.5 m freeboard should be provided.

The depth (D) chosen for any particular lagoon depends on site considerations (presence of shallow rock, minimisation of earthworks). The depth should exceed 1.5 m so that dried sludge resulting from water evaporation can be deposited for approximately one year.

Ideally, embankments should be constructed from the soil excavated from the Site, and there should be a balance between cut and fill, although it is worth noting that lagoons constructed completely in cut may be a cheaper alternative, especially if embankment construction costs are high.

The soil used for embankment construction should be compacted in 150-250 mm layers to 90% of the maximum dry density as determined by the modified Proctor test. Shrinkage of the soil occurs during compaction (10-30 percent) and excavation estimates must take this into account. After compaction, the soil should have a coefficient of permeability, as determined in situ, of $<10^{-7}$ m/s.

Wherever possible, embankment design should allow for vehicle access to facilitate maintenance. Embankment slopes are commonly 1 to 3 internally and 1 to 1.5-2 externally. Steeper slopes may be used if the soil is suitable; slope stability should be ascertained according to standard soil mechanics procedures for small earth dams. Embankments should be planted with grass to increase stability: a slow-growing rhizomatous species should be used to minimize maintenance.

External embankments should be protected from storm water erosion by providing adequate drainage. Internal embankments require protection against erosion by wave action, and this is best achieved by in situ concrete or stone rip-rap at top water level. Such protection also prevents vegetation from growing.

Prevention of soil contamination

To protect the environment against the possible migration of hazardous substances the pathways and geological barriers must be identified.

As a general guide for the sub-soil permeability, the following interpretations may be placed on values obtained for the in situ permeability coefficient:

- $k > 10^{-6}$ m/s: the soil is too permeable and the lagoons must be lined;
- $k > 10^{-7}$ m/s: some seepage may occur, it is advisory to use a geotextile liner;

- $k < 10^{-8}$ m/s: the sub-soil will seal naturally; but still use a geotextile liner for safety reasons;
- $k < 10^{-9}$ m/s: there is no risk of groundwater contamination, if the groundwater is used for potable supplies use a geotextile liner for safety reasons;
- $k > 10^{-9}$ m/s and the groundwater is used for potable supplies, a geotextile liner is not essential.

In order to prevent soil contamination or to affect the groundwater quality the lagoon shall be lined. The liner construction shall comprise the haulage and placement of selected materials suitable for liner construction. The liner materials will be spread in thin lifts and thoroughly compacted.

The Contractor will be required to control the moisture content and compaction of the fill to ensure that the required fill density is achieved, A QA plan shall be provided to confirm that the required moisture content, density and permeability are achieved on each lift of the clay liner.

Particular care must be taken to ensure that the sump is properly lined with clay and that the surface of the clay liner throughout the lagoon excavation is suitable to receive a geomembrane liner. The Contractor will be required to spray the surface of the clay liner periodically with clean water to prevent the formation of desiccation cracks.

A variety of lining materials is available and local costs dictate which should be used. Satisfactory lining can be achieved with ordinary Portland cement (8 kg/m²) or with plastic membranes on 150- 300 mm layers of low-permeability soil.

If plastic membranes are used the preference will be given to a HDPE geotextile liner. The installation of this liner shall be carried out by a specialist Sub-Contractor experienced in the supply, deployment and seaming of HDPE geomembrane liners.

If plastic membranes are used the Contractor will be required to use plant and operating procedures that ensure that the protection layers are placed to the required thickness without causing damage to or displacement of the underlying liner materials. The Contractor will not be permitted to operate plant within 1.0 m of the geomembrane liner.

The geotextile protection layer shall be anchored with sandbags. If this work is carried out during the summer months it is probable that night working will be required as daytime temperatures may be too high. The QA programme will address conformance testing of the geomembrane and geotextile materials.

All seams shall be tested to confirm continuity and a programme of destructive tests will be established to ensure that seam strength criteria are achieved.

On completion of the HDPE layer a sand protection layer shall be placed to the required thickness (min. 0.75 m) taking care not to damage the liner system. Leak location surveys shall be carried out to ensure the integrity of the geomembrane liner prior to the start of filling the lagoon.

	client:	REMPEC			
	project:	Port Reception Facility, Bar, Montenegro			
	title:	Functional Specification Oily Waste Treatment and Port Reception Facility			
office: Velsen	Order: 35305	document: 0	rev.: 0	sheet: 21	of: 48

3 General Specifications

3.1 Responsibility

The Tenderer is responsible for the completeness and accuracy of his design calculations and for compliance with all applicable requirements of this specification.

The Contractor shall be obliged to prepare and submit a Hazard Analysis and Risk Assessment (HARA) for his plant.

If during the Tender preparation unexpected factors may arise which in the judgment of the contractor justify deviations from the specified requirements but which do not affect the guarantees as requested for by this specification, the Tenderer may propose adequate variations and be bound by the same conditions, so far as applicable, as though the said variations were stated in this Specification. The Contractor shall not alter any of the Works except as directed in writing by the Owner.

The Contractor shall in the manufacture of the Plant and in the execution of work on Site observe and comply with and be bound by the laws of the country of manufacture concerning the manufacture of the Plant and the laws of the country where the Plant is to be erected and work to be executed so far as such laws concern the manufacture erection and operation of the Works.

3.2 Detailed Design

Before commencing any part of the Works the Contractor shall submit his detailed design for the approval of the Owner. The detailed design shall be unambiguous and facilitate the assessment of the technical execution.

The grading of a treatment plant and the location of the units and service building can be important factors in its successful operation. The grading must provide protection against storms and natural drainage patterns must be used as far as possible.

Roadways, walkways, and the location of buildings must meet the operational requirements of a site.

Some conceptual information on those items is given in the annex K:

- process Flow Diagrams;
- plot and Site Plans.

3.3 Standards and Regulations

As a minimum shall goods, materials and workmanship comply with the latest issue of the National or International Standards or Code of Practice as referred to in this Specification, or comply with alternative equivalent internationally recognised Standards.



client:	REMPEC
project:	Port Reception Facility, Bar, Montenegro
title:	Functional Specification Oily Waste Treatment and Port Reception Facility

Full details in English//national language of alternative equivalent internationally recognised standards for works proposed shall be provided with the Tender.

All materials, construction, inspection, testing and all aspects of design shall be in compliance with:

- a) Codes and Standards as afore defined;
- b) Current Good Engineering Practices;
- c) European or American Directives (if applicable).

All the possible measures and precautions shall be taken to account during lay-out and installation that operation, maintenance and service can take place without hazards to the personnel.

The equipment shall also be designed to prevent the physical exhaustion of the working personnel in order to minimise the risk of occupational hazards.

More specifically shall the following standards, codes and guidelines be adhered to (as far as reasonably practical):

- European directives such as Machinery Directive, Low Voltage Directive, Electro Magnetic Compatibility Directive, Pressure Equipment Directive (PED), ATEX directive etc.;
- EHEDG design guidelines, especially guidelines 8, 9, 14, 16 and 18 for piping;
- CE marking.

3.4 Battery limits

3.4.1 Basic interface connections

The following basic interface connections are considered:

- The locations and elevations of all Process Battery Limits will be indicated in the requisition (not part of this document).
- The Battery Limits conditions and Utility conditions will be indicated in the requisition (not part of this document).
- All Battery Limits of all piping shall be flanged connections.

3.4.2 Battery Limits Tenderer

- one power cable at the motor control centre or power distribution cabinet located in the building;
- the control panel in the building;
- piping (flanged) at the truck unloading platform;
- vendor is requested to define the battery limits in detail in his proposal;
- tenderer is requested to define the battery limits in detail in his proposal.

	client:	REMPEC			
	project:	Port Reception Facility, Bar, Montenegro			
	title:	Functional Specification Oily Waste Treatment and Port Reception Facility			
office: Velsen	Order: 35305	document: 0	rev.: 0	sheet: 23	of: 48

3.4.3 Battery Limits Packaged units

- one power cable for each packaged unit terminating in the electric motor terminal box or power distribution cabinet;
- one instrument junction box for each individual packaged unit located at the edge of that unit;
- one pressurised instrument air connection for each individual packaged unit located at the edge of that unit;
- piping (flanged) at the edge of the unit;
- vendor is requested to define the battery limits in detail in his proposal.

3.4.4 Details Battery Limits

The vendor shall list all remaining interface connections and specify all relevant details, such as:

- lay-out drawing showing the proposed locations and elevations;
- type of interface;
- detailed dimensional drawings;
- materials used;
- applicable pipe specifications (code, class, material, size schedule, facing finish etc);
- maximum allowable loadings;
- utility consumptions Min operating / Normal operating / Max operating / Peak Load;
- max allowable pressure losses.

3.5 Documentation

Shop drawings and calculations shall be submitted to Owner for approval before starting fabrication. Each shop drawing shall be fully checked and signed as checked by the Contractor or his representative before it can be accepted for approval. Shop drawings shall have the nozzle numbered and lettered, corresponding to the individual vessel drawing or data sheets. The approval of drawings, calculations and welding procedures by Owner does not release the Contractor of his responsibility.

3.5.1 Manufacturing report

The Contractor shall issue a certificate that the equipment has been designed, fabricated and tested in accordance with this specification and the requirements of the local and national rules and regulations. This inspection and test report shall be countersigned by the Inspecting Authority that it has been so constructed and tested accordingly. The countersigned certificate shall be furnished to Owner.

The manufacturing report shall include:

1. index;
2. copy of the purchase order;
3. copy of all shop drawings with equipment lists;
4. copy of the calculations;
5. copy of authority approval letter and other important correspondence;
6. approved welding procedure specification;



client:	REMPEC
project:	Port Reception Facility, Bar, Montenegro
title:	Functional Specification Oily Waste Treatment and Port Reception Facility

7. material certificates with a reference to the drawing and part number;
8. sketch showing the location of radiographs and film numbers;
9. results of non-destructive examination and destructive testing;
10. inspection and test report;
11. photograph of the nameplate and/or number plate.

3.5.2 Documents for regulatory approvals by relevant authorities

The Contractor shall provide drawings needed to apply official permits, certificates, regulatory approvals and licences from relevant authorities. The Owner shall assist in the preparation of such documents.

3.5.3 As-built drawings

As-built drawings shall be prepared of each part of the Works. These drawings shall include but not be limited to the following:

- (a) site map showing the Location of the part of Works on the plot;
- (b) elevations;
- (c) plans and sections;
- (d) details of installations;
- (e) any other drawing as may be agreed between the Owner's Representative and the Contractor.

The scales of the as-built drawings are recommended in section 5.4.7 but shall be specified in the Contract Documents.

3.5.4 Manuals

For each item/equipment supplied by the Contractor, manuals shall be prepared for installation, operation and maintenance instructions. These manuals shall include all installation details and particulars, list of parts and related explosion drawings, catalogues, test certificates and test records, operating instructions and any other information or instructions which may be needed or required or useful in the installation, operation, maintenance, repair, dismantling or assembling of the equipment and for repair and identification of parts for ordering replacements. The manuals shall be collected under a suitable common cover as listed below. If the Contractor's standard bulletins are supplied, they shall be clearly marked to indicate the specifications applicable to the particular equipment which is supplied. Prints of drawings reduced to suitable size shall be included in each instruction book.

Installation Manuals

The Installation Manuals, which shall be issued in A 4 size format, shall simply and clearly define all the installation details, physical dimensions of the Plant and, if necessary, all safety requirements during the installation. The booklets shall have separate sections setting out instructions on a 'do' or 'do not' format.

Operation Manuals

The Operation Reference Manuals, which shall be issued in A 4 size format, shall simply and

	client:	REMPEC			
	project:	Port Reception Facility, Bar, Montenegro			
	title:	Functional Specification Oily Waste Treatment and Port Reception Facility			
office: Velsen	Order: 35305	document: 0	rev.: 0	sheet: 25	of: 48

clearly define all the aspects necessary to enable the user or operator to safely and efficiently operate the plant equipment. The booklets shall have separate sections setting out instructions on a 'do' or 'do not' format.

The Operation Manuals shall be formulated and sectioned appropriately for the Training Programme the Contractor will be utilising when training the Owner's operational staff.

Maintenance manuals

The Maintenance Reference manuals shall be in A 4 size, in loose leaf folder format. The equipment shall be in alphabetic order. Each individual manual shall have main sections for each of the disciplines according to the principle given by the Owner's Representative.

Each main section shall have subsections as follows:

1. general data of each machine or item;
2. condition monitoring and fault diagnosis (trouble shooting guide);
3. schedule of planned maintenance routines (daily, weekly, monthly, annual etc.);
4. detailed description of operation;
5. service procedure;
6. method of component removal (explosion diagrams);
7. repairs including use of special tools;
8. test procedure following maintenance and repairs;
9. schedule of special tool required;
10. lubrication (lubricant, quantity, sequence of change).

Cross reference shall be made to relevant drawings where applicable in the maintenance manual text. Extensive use shall be made of photographs wherever possible to illustrate maintenance procedures.

3.5.5 Submittal, review and approval of documents

The copies (number stated in appropriate clauses) of each drawing shall be submitted to the Owner's Representative to which a log (control) number has been assigned.

If any revision is made to a drawing after it has been approved, the Contractor shall re-submit appropriate number of prints to the Owner's Representative for further approval. The Owner's Representative shall have the right to request for any additional details and to ask the Contractors to make any change in the drawings which are necessary to conform to the provisions and intent of the Owner's Requirements without additional cost.

3.5.6 Other instructions for documents

The drawings and calculations which have to be produced by the Contractor shall be made and submitted in accordance with the following regulations:

A choice of recommendable metric scales are 1:500, 1:100, 1:50, 1:20, 1:10, 1:5, 1:2 or 1:1, depending on the kind of drawing and/or details which have to be drawn.

All costs, related to the supply to the Owner's Representative of the mentioned number of

	client:	REMPEC			
	project:	Port Reception Facility, Bar, Montenegro			
	title:	Functional Specification Oily Waste Treatment and Port Reception Facility			
office: Velsen	Order: 35305	document: 0	rev.: 0	sheet: 26	of: 48

drawings and calculations, shall be included in the Contract Price.

3.6 Coordination and Inspections

In order to ensure that the public health and environmental requirements will be met during the implementation of the project there shall arrangements be made for an 'Engineer' to represent the Owner and to carry out duties that will later be specified in the Contract Documents. The Contractor shall also denominate a responsible representative in his Tender.

The Engineer shall have the right to ask for witness tests on the main components before dispatch to Site. During the period of site installation the Engineer will carry out inspection of the Works to ensure the standards of workmanship meet the Specification and are to his satisfaction. After completion of various parts of the installation the Contractor shall provide a test engineer, labour and materials to demonstrate to the Engineer that the plant meets the agreed target.

All equipment shall be tagged at an accessible point with a nameplate with engraved the following data:

- supplier;
- type;
- year of manufacturing;
- main engineering data.

Vessels and other items which are subject to authority approval need additionally be tagged in accordance with the authority regulations.

3.7 Testing, inspections and guarantees

3.7.1 Quality Requirements, Testing

Shop tests

Tenderer shall perform in his shop all the required tests. Tenderer shall include in his quotation full details of the intended test program including measurement procedure.

It shall be the Contractor's responsibility to liaise with and co-ordinate the activities of his sub-contractors associated with any part of the Works and to ensure that all parties concerned are present during any tests to obligate their responsibilities within the defined limits to their individual contracts.

Test certificates shall be provided giving detailed records of all electrical and mechanical tests carried out on the equipment and material including lifting equipment, tanks, pressure vessels, and cables and cabling both in the manufacturer's works and at Site.

Site tests

Leakage tests at the test pressure shall be carried out on all erected pipe work and valves



client:	REMPEC
project:	Port Reception Facility, Bar, Montenegro
title:	Functional Specification Oily Waste Treatment and Port Reception Facility

immediately after erection and before being built in. The Contractor shall advise the Engineer when these tests are to be carried out.

The site trials shall be carried out under the control of the Contractor's staff and the supervision of the Engineer. The Contractor shall provide all the necessary labour and instrumentation to conduct the tests.

3.7.2 Guarantees

Tenderer shall guarantee that the equipment offered will be free from fault in design, materials and workmanship and will perform satisfactorily in accordance with the service and performance conditions specified.

The Contractor's guarantees given when tendering in respect both of performance and efficiency will be binding and considered part of the Contract.

Contractor shall promptly correct or replace any and all defects found in the mechanical design, materials or workmanship in the purchase order to the full satisfaction of Owner (without any additional costs).

The fulfilment of these guarantees shall be verified at the works test and at Site trials in accordance with the procedure given in the latest editions of ISO 2548 and IEC 60034 etc.

3.7.3 Inspections

The equipment shall be inspected by Owner during construction. Sufficient inspections shall be made to ensure that the materials, construction and testing comply in all respects with the requirements of the local and national authorities and this specification. Any approval given by an Inspection Authority or by the Owner does not absolve the Contractor from his responsibility for compliance with the applicable requirements of this specification.

3.7.4 Performance testing

The site reliability trials shall be carried out in accordance with ISO 1204 under the control of the Contractor's staff and supervision of the Engineer. The purpose of the site tests will be to confirm the works tests for the purpose of comparison with the Guarantees entered in the Contract. In addition performance testing during one year shall be carried out to measure whether the process guarantees will be met based on the basis of design.

Furthermore, the effluent quality will be monitored to determine if the limits for irrigation use of treated industrial wastewater as per JS 202/2003 will be met. However, the Tenderer is not liable for meeting the limits according JS 202/2003 other than the process guarantees. The effluent will be discharged into the sewage system if the limit will be exceeded.

3.8 Spare parts

With the quotation the Vendor shall quote for the recommended spare parts for the complete

	client:	REMPEC			
	project:	Port Reception Facility, Bar, Montenegro			
	title:	Functional Specification Oily Waste Treatment and Port Reception Facility			
office: Velsen	Order: 35305	document: 0	rev.: 0	sheet: 28	of: 48

Packaged System as specified in the Required Documents.
Spare parts shall be available for 20 years after start-up.

3.9 Commissioning and Take Over

The objective of all commissioning activities is to verify that equipment, system(s) and/or facilities meet the design and engineering specifications and to obtain documentary evidence of this.

These objectives are mainly achieved by carrying out inspections, checks and tests and reporting the findings throughout the project.

The commissioning activities start as soon as the construction drawings are issued. These preparatory activities mainly take place at the office and the first pre-commissioning activities at the site will be carried out when the majority of the equipment has been installed. The remaining commissioning activities follow and will end when the plant has been formally accepted by or on behalf of the Owner including any adjustments or variations to the Tender agreed between the Owner and the Contractor.

3.10 Training for operation and maintenance

3.10.1 General

The Contractor shall provide training to personnel assigned by the Owner's Representative. Training shall commence during the construction period and continue throughout the Commissioning period.

3.10.2 Training Programme

The Contractor shall provide a fully detailed training programme, based on the training programme submitted with his Tender, within two (2) months of the commencement of the Contract.

The training programme shall include, but need not be limited to, the following:

- 1) the organisational structure of the personnel required for management, operation and maintenance of the Works;
- 2) the manpower requirements, by skills and trades, necessary for the management, operation and maintenance;
- 3) reference materials and documents to be provided in the training programme.

3.10.3 Contractor's Training Personnel

The Contractor shall provide supervisory personnel for each of the positions required for operation and maintenance of the Works as identified in the training programme. The duties of each of the training personnel, hereinafter referred as Contractor's Counterpart Staff, shall be to supervise and train the staff members to operate and maintain that element or those elements of the Works appropriate to his position. The emphasis shall be on 'hands-on'



client:	REMPEC
project:	Port Reception Facility, Bar, Montenegro
title:	Functional Specification Oily Waste Treatment and Port Reception Facility

training.

The Owner's Representative shall provide sufficient workforce for the operation and maintenance of the Works under the supervision of the Contractor's Counterpart Staff. It is envisaged that no less than 2 persons of such Contractor's Counterpart Staff will be at the Works.

3.10.4 Safety Training

The Contractor shall pay particular attention to safety training for all assigned personnel. Safety training shall not be limited to personal safety but shall also include detailed actions to be taken by all staff in emergency situations and the use of all safety equipment.

3.10.5 Language for Training

Training shall be carried out in the National language or English.



client:	REMPEC
project:	Port Reception Facility, Bar, Montenegro
title:	Functional Specification Oily Waste Treatment and Port Reception Facility

office: Velsen	Order: 35305	document: 0	rev.: 0	sheet: 30	of: 48
----------------	--------------	-------------	---------	-----------	--------

4 Specification for Mechanical Works

4.1 Service life

The facility shall be designed for uninterrupted continuous operation of at least 8000 hours per year with a minimum service life of 20 years for process equipment and 25 years for structures, tanks and other static equipment with the application of planned maintenance.

The Tenderer/Vendor shall design the equipment, select construction materials and apply service factors such that the required service life can be achieved. All analysis, decisions and actions shall be documented and made available for review if requested.

4.2 General Requirements

Vendor is responsible for the material selection suitable for the process duty.

Machinery for outdoor applications shall be equipped with weather protection:

- electrical motors shall be equipped with easily detachable weather shields;
- geared drives of scrapers shall be equipped with easily detachable shield cabinets furnished with cooling air grilles and hinged hatch with snap locks to facilitate the maintenance;
- all the measuring equipment shall be positioned to heated, insulated and splash proof cabinets.

4.3 Tanks

The tanks shall be fabricated according API 200 rules. The tanks will be operated at atmospheric pressure. The design pressure will be terminated during detailed engineering and shall be verified by Vendor through calculations.

The supply shall include:

- internal and external coating;
- nozzles fore breather valves, drain, inlet, outlet, flow indicator;
- flame arrestor;
- cage ladder;
- railing;
- two manhole;
- two earthing lugs;
- nameplate;
- anchor bolts.

The slop oil tank T-103 shall be supplied with a heating coil or equivalent, including insulation or other appropriate provisions.

4.4 Erection of tanks

Welded vertical tanks can be satisfactorily erected in several ways; no single particular



client:	REMPEC
project:	Port Reception Facility, Bar, Montenegro
title:	Functional Specification Oily Waste Treatment and Port Reception Facility

system of erection procedure is specified for use.

Erection contractors normally have their own specific individual method which they have adopted as the result of experience, and have developed the erection technique most suitable for economical working and good workmanship by their field crews.

Provided that the erection contractor employs a method which is known to give good results and that the recommended sequences of erection and welding are followed, the method may be deemed satisfactory. Tenderers shall outline their method of erection before a contract is placed.

During erection, tanks shall be safeguarded adequately against distortion or damage due to wind pressure by the provision of suitable steel wire guys, temporary girders or braces.

Holes in plate work in order to assist in erection are not permitted. Lugs, nuts, clamps, and other devices to assist in erection may be attached to the tank plates by welding, but all such attachments required only for the purposes of erection shall ultimately be removed and any noticeable projections of weld metal remaining shall be carefully ground or chipped away.

The foundation shall remain level as the tank shell is erected. For this reason the foundation shall be checked, not only at the commencement of erection but also several times during the various stages of tank erection. The measurements shall be stated in the manufacturing report.

On site erected tank shells of fixed roof tanks shall be hydrostatically tested after completion of the roof. Testing shall be done by filling the tank with fresh water to the level of the top leg of the top curb angle, and noting any leaks over a period of at least 24 hours.

After the tank shell has been tested with water, the roof shall be tested by pumping air under the roof plates while the tank is still full of water. The influence of sudden barometric changes and possible condensation during the night shall be considered. Non-pressure tank roofs shall be tested to a pressure of 7.5 mbar. For the detection of leaks, soap suds or similar substance shall be applied to all joints.

4.5 Pumps

The pump duty shall be in accordance with the specified Module type in connection with the capacities indicated on the corresponding process flow diagram and the tables 7 to 12.

Tenderer shall as a minimum specify the following criteria for each pump:

- Number of pumps installed (*)
- Pump type (*)
- Total capacity: (*) m³/h
- Estimated differential head: (*) bar
- Casing Material: (*)
- Impeller Material (*)
- Installed power: (*) kW
- Absorbed power: (*) kW



client:	REMPEC
project:	Port Reception Facility, Bar, Montenegro
title:	Functional Specification Oily Waste Treatment and Port Reception Facility

Pumps shall be generally equipped according to the following list with:

- feed valve;
- shut off valve;
- check valve (if applicable);
- air removal valve DN 25 of stainless steel with breather pipe DN 25 to sump;
- drain pipe for stuffing box bleed;
- pressure gauge in pressure pipe between pump and shut-off valve;
- for the pumps equipped with vacuum evacuation system the stuffing boxed shall be equipped with pressurized water lubrication to minimize leakages when vacuum is applied;
- for sludge and sewage pump stuffing boxes the grease lubrication is preferred (all submersible pumps shall be delivered with oil lubrication). The water lubrication may be applied only in cases of very abrasive medium;
- if not otherwise requested all the pumps shall be equipped with dry running protection;
- motors shall be squirrel cage motors, 2800 rpm;
- base plate;
- anchor bolts.

4.6 Pipes

Tenderer is responsible for all piping. The piping part of the packaged units shall be provided by the Vendor. A pipe bridge (4 meter high) shall be included between the tank farm and the slop oil collection sump. Piping standards shall be according DIN, ASTM or equivalent.

The Vendor will define the design load for nozzles of equipment. Tenderer shall calculate the design of the complete piping outside the packaged units, including the location of anchorage and pipe supports.

Interface points at the Battery Limits shall be flanged and shall be anchored in such a way that no additional stress, including temperature stress, will be transferred to piping outside the packaged units.

Pipe work shall be conform classification DIN 11850 (piping) and DIN 11851 for accessories (flanges etc.). For pressures above 1 MPa, the flanges shall be dimensioned according to DIN 2505.

Pipe work exposed to the occurrence of vacuum or destined for a pressure exceeding 0.6 MPa shall be calculated individually according to the instructions for standards of the pressure vessels.

Elbows for dimensions greater than DN 300 may be manufactured of pipe segments. For pipe diameters DN 300 and smaller pressed elbows shall be used.

Tees shall always be factory made or produced with collaring draw method. Extra welding joints shall be avoided by selecting and adjusting the tees to fit in pipe work lengths. Small branches $D:d = 4:1$ and smaller may, however be manufactured on site without collar.

	client:	REMPEC			
	project:	Port Reception Facility, Bar, Montenegro			
	title:	Functional Specification Oily Waste Treatment and Port Reception Facility			
office: Velsen	Order: 35305	document: 0	rev.: 0	sheet: 33	of: 48

The joints in the pipe work shall be made by welding or with weldable collars and flanges, avoiding threaded joints. The threaded joints shall in any case be limited to sizes DN 50 and under.

The flanges and collars shall be as follows:

Collars

- pressed collars may be used in pipe work dimensions below DN 200 with pressures up to 1 MPa and/or dimensions below DN 400 with pressures up to 400 kPa;
- collars formed of angle iron shall be used with pipe work from dimension DN 200 or greater with pressures above 400 kPa; and
- smitten and formed collars or welding rings shall be used exclusively in pipe work with dimensions of DN 200 or greater and pressures above 400 kPa.

Flanges

- aluminium flanges may be used in pipe work dimensions below DN 250 with operation pressures under 1 MPa;
- galvanised steel flanges shall be used exclusively for dimensions DN 300 and greater;
- the flanged joints underground shall be equipped with galvanised steel flanges with 400 µm epoxy tar coating on top of Sa 2 1/2 sand blasted basis and associated primer basecoat.

Nozzles

The Tenderer shall submit allowable nozzle loadings (horizontal and vertical forces and moments) for all nozzles.

Supports

The supports of the pipes shall be installed into the tanks or alike to submerged stresses shall be constructed of stainless steel. The supports in dry rooms and gangways shall be manufactured of mild steel and painted.

The supports shall allow the stripping down of valves and appliances without dismantling the supports.

The ISO -standards shall be observed on applicable parts:

- pipe clamps and their billets;
- hanging supports;
- sliding supports;
- for stainless steel pipes the possible reinforcement of pipe surrounded by fixed support and axial fixing plates shall be calculated case by case.

4.7 Valves

For the installation of valves following aspects shall be observed:

- accessibility for maintenance;
- space requirement for actuator maintenance;
- position of spindle, requirements of medium and operation;
- space required for removal of shaft of check valve;

	client:	REMPEC			
	project:	Port Reception Facility, Bar, Montenegro			
	title:	Functional Specification Oily Waste Treatment and Port Reception Facility			
office: Velsen	Order: 35305	document: 0	rev.: 0	sheet: 34	of: 48

- design of needed lifting points and assembly hatches.

The manual actuators shall be selected so that the required operation force in sustained service shall not exceed 200 N and temporarily 500 N.

Gate valve with resilient wedge gate

- the body of cast iron, lifting spindle;
- gate shall be housed and sealed so that the solid substances are prevented from penetrating to sluice housing;
- flanges and drilling according to PN 10 (DIN 2501);
- internally the valve shall be plastic coated, coating at least 70 µm;
- rated pressure PN 10.

Butterfly valve of sealing construction

- body and flap of cast iron or material of similar rigidity and corrosion resistance;
- rated pressure PN 10 up to DN 500;
- flanges and drilling according to PN 10 (DIN 2501) or in waffle models installation between PN 10 flanges.

If not requested otherwise, the electric motor actuators shall be equipped with following features:

- device for manual operation;
- limit indicators suitable for remote control;
- momentum switches for over load and limit stops;
- adjustable control device to park the valve in intermediate positions.

If the actuator is for outdoors application this shall be suitably equipped for purpose.

For drainage application threaded globe type valves shall be used.

4.8 Corrosion Protection, Painting

The oily waste from ships may contain seawater to a certain extent. The susceptibility to corrosion shall be minimized through the use of corrosion resistant materials or the application of protective internal coatings. Care shall be taken to prevent galvanic corrosion.

The choice of material should be based on life cycle economics, taking into consideration the type of service (water temperature, level of chlorination), the cost of material (noting that higher allowable water velocities imply smaller line sizes), the physical location and the extent of pipe work within the installation. Typical materials which may be considered for an extremely rugged construction include super duplex, high molybdenum stainless steels and glass fibre reinforced thermosetting plastic (GRP).

The following qualities stainless steel are not seawater resistant without further protection:

- AISI 304 corresponding with EN 10088-1...2, DIN 17006 WS No. 4301;
- AISI 316 corresponding with EN 10088-1...2, DIN 17006 WS No. 4436.

The following types of gaskets should be used in seawater systems (in order of preference):

	client:	REMPEC			
	project:	Port Reception Facility, Bar, Montenegro			
	title:	Functional Specification Oily Waste Treatment and Port Reception Facility			
office: Velsen	Order: 35305	document: 0	rev.: 0	sheet: 35	of: 48

- mineral filled gaskets;
- GRE laminated gaskets;
- spiral wound gaskets with graphite filler with an inner ring more cathodic than the adjacent piping.

Plain graphite gaskets shall not be used with corrosion resistant alloys.

The following protection is proposed:

Steel and Cast Iron Surfaces in Submerged Areas

Epoxy bitumen combination: four (4) layers of epoxy paint; one primer, three (3) epoxy bitumen paint. Thickness of final coating 400 µm. Primer applied on the sand blasted dry steel surface, cleaning according to standard SA 2 1/2. The surfaces in contact with concrete shall also be painted.

Steel and Cast Iron Surfaces in Climatic Stresses

Epoxy paint combination: three (3) layers of epoxy paint; one primer, two (2) suitable final epoxy coatings. Thickness of final coating 180 µm. Primer applied on the sand blasted dry steel surface, cleaning according to standard SA 2 1/2.

If the chalking of the epoxy paint is ungainly or harmful, respective polyurethane paint combination shall be used.

Surfaces with Hot Dip Galvanising

The surfaces in Climatic Stresses epoxy with epoxy paint combination: two (2) layers of epoxy paint; one primer, one suitable final epoxy coating. The metal surface must be chemically cleaned of dirt and grease. Thickness of final coating shall be 100 µm.

The hot dip galvanising shall conform to the instructions of ISO 1459 and ISO 1461 standards. In not requested otherwise in Detailed Specifications, the average zinc quantity on 5 mm and thicker steel structure shall conform to the specification ZnK 500 (respective zinc layer 70 µm) and under 5 mm tick structures ZnK 420 (respective zinc layer 60 µm).

The requirements presented in the ISO-standards shall be observed when designing and manufacturing structures.

The corrosion protective painting of machines and equipment shall at least conform the ISO 2064 (Metallic and Other Non-organic Coatings) standards and specifications.

4.9 Noise requirements

For all systems and equipment overall sound power level shall be <65 dB (A)/m².

4.10 Maintenance

The unit shall be designed to operate continuously and unattended with a minimum of inspection and maintenance. Time of uninterrupted operation will be at least two years. Tenderer's inspection and maintenance philosophy including detailed inspection and maintenance schedule shall be submitted with quotation.

	client:	REMPEC			
	project:	Port Reception Facility, Bar, Montenegro			
	title:	Functional Specification Oily Waste Treatment and Port Reception Facility			
office: Velsen	Order: 35305	document: 0	rev.: 0	sheet: 36	of: 48

5 Specification for Civil Works

5.1 General Requirements

The Civil Works shall be designed according to modern internationally accepted codes. The buildings shall be constructed according to the quality requirements of this functional specification following accepted international standards, like ISO, EN, DIN, BS and/or AIA.

5.2 Civil works scope

The civil works shall include but not limited to:

- the building;
- tank farm with curbs;
- truck unloading area with drainage pits;
- tank slaps for the reception tank, slop oil tank and sludge buffer tank;
- pits;
- slop oil collection sump;
- sewers;
- provisions for pipe supports and pumps;
- the two lagoons and lining;
- excavation.

5.3 Earthworks

5.3.1 Levelling and roads

Levelling of the plot will be done by the Owner and is not part of the scope of the Tenderer. Also construction of roads will be provided by the Owner.

5.3.2 Excavations

Excavation shall be carried out to such dimensions as will permit adequate dewatering, proper support of the sides of the excavation, the erection of shuttering, placing of concrete and fill including compacting and any other construction operation. The Contractor shall keep the excavations free from water from whatever source, so that the Works shall be constructed in dry conditions. He shall also prevent slips and falls of material from the sides of the excavations and embankments.

In the event of slips, or falls in the excavations the unsuitable material entered in the trench is to be removed and the additional backfilling that may be required. Water must be kept 500 mm under trench bottom.

5.3.3 Supporting the Excavations

Because of the quality of the soil and especially when difficult ground water situations are present the Contractor shall take extra care when excavating adjacent to existing structures. In order to prevent collapsing the excavation walls and damages to the existing buildings, the



client:	REMPEC
project:	Port Reception Facility, Bar, Montenegro
title:	Functional Specification Oily Waste Treatment and Port Reception Facility

Contractor shall be responsible for the supply and installation of steel sheet piles of sufficient strength and thickness to withstand driving, to obtain required locking, and to resist harmful distortion and/or buckling due to soil pressure.

5.4 Building

The building will be constructed with concrete exterior walls whereas interior walls could be manufacturer's standard. The floor will also be made of liquid resistant concrete. The roof will be constructed with light weight concrete panels. Concrete foundation beams will be provided. All provisions for lighting, earthing, ventilation, air conditioning and refurbishment shall be included. The building will have 5 doors and three overhead doors in such a way that access is possible for erection of equipment. The building shall be painted.

5.5 Concrete and reinforcements

Structural concrete is made of Portland cement or where required or ordered, sulphate resisting cement and clean good quality aggregate. Concrete is classified according to 28-day compressive strength.

Concreting and after treatment (to prevent drying, protect from high temperatures and wind) of surfaces shall be made. Extra vibrating of upper parts of more deep than 0.4 m concrete casts shall be made about 2 hours after cast work to help concrete setting without cracks.

5.5.1 Water Proof Concrete

Water proof concrete for basins and reservoirs shall have a strength of minimum 40 N/mm², water proof tested according to standards and water cement ratio maximum 0.49. The testing of waterproofing shall be made according to the codes and the results shall be presented to the customer. Structural design of water proof structures shall be made for easy casting and spaces for the vibrator. All concrete and reinforcement shall be designed for limited tensile stress to avoid cracks. Water proof construction joints must be equipped with injection tubes. Treatment of fresh water proof concrete surfaces shall be made to avoid fast drying.

Production of structural and water proof concrete shall be made by mechanical mixers and by weight batching. Water to be used for concrete shall be tested to standards. Quality control of concrete is made according to standards.

5.5.2 Reinforcement

Bar reinforcement shall be of hot rolled high yield ribbed steel, grade minimum 400, or cold worked steel deformed bars grade minimum 500. Cold deformed bars shall come with certificate.

Reinforcement shall be clean and free from loose material, loose rust, grease and other which can weaken the bond. Welded reinforcement units shall be to standards.

	client:	REMPEC				
	project:	Port Reception Facility, Bar, Montenegro				
	title:	Functional Specification Oily Waste Treatment and Port Reception Facility				
office: Velsen	Order: 35305	document: 0	rev.: 0	sheet: 38	of: 48	

Concrete cover of reinforcement shall be according to standards, in general minimum 35 mm in columns, beams and water proof structures. If applicable protective coatings shall be applied to concrete structures to protect concrete against acid ground water or other chemical attacks.

5.5.3 Water retaining structures

The inside of shuttering shall be coated with non-staining mineral oil, mould cream emulsion or with other approved material which shall not be allowed to come into contact with adjacent concrete or the reinforcement.

Except where otherwise specified, shuttering for concrete faces which will remain exposed in the Permanent Works, shall be 'wrought' shuttering, i.e. it shall prevent the loss of any ingredients from the concrete and will produce a dense smooth surface without discontinuities of line, texture or appearance.

Also the shuttering for faces which will remain hidden in the Permanent Works, shall be 'back' shuttering, i.e. it shall prevent the loss of any ingredients from the concrete and will produce a dense concrete surface.

5.5.4 Finishing of Concrete Surfaces

All finishing work, either by means of a metal trowel or wooden float, shall be executed directly after the concrete has been cast and before the concrete is set.

The top surfaces of process basins, channels, gullies, walls and concrete fillings of structures which are not to be covered shall be floated off to a smooth finish by means of a flat steel trowel. Floor surfaces shall be floated off by strewing Portland cement onto the concrete surface.

5.5.5 Brick and concrete block work

The bricks, blocks and mortar for exterior walls shall be sound, hard, well baked throughout their mass, have straight edges and be frost resistant. Mortars shall be lime-cement based. Reinforcement over openings shall be of stainless steel.

Bricks and profiles shall be of good quality, sound, hard, well baked, with uniform dimensions and shapes and of an approved type and colour.

Outside surface plasters shall be lime-cement based. Application shall be made in three layers, nominal thickness 20 mm, minimum 15 mm. First layer is splashing with maximum cover 80 %, second 15 mm and third 5 mm. The bond of plaster is to be minimum 0.3 N/mm².

Sealing of facade concrete units and other joints is to be made by elastic polysulfide or polyurethane sealant material according to local standards and/or Euro-codes. A round polyethylene strip is applied to give good bottom shape for joint material. The bond to concrete, plaster, metal or other is controlled according to Standards.



client:	REMPEC
project:	Port Reception Facility, Bar, Montenegro
title:	Functional Specification Oily Waste Treatment and Port Reception Facility

5.6 Roofing

Roofing felt shall comply with the local requirements. Extra guarantee of ten years of no leaking shall be applied to roof structures.

Each roof will be carefully inspected when ready. Roofs with inside water outlet are water tested with minimum 150 mm water near gullies

Where bitumen will be used the elasticity of SBS-bitumen roofing shall be min. 15 % for minus degrees in temperatures. Tensile strength of 2 layers of EPDM roofing is minimum 15 kN/m.

The minimum thickness shall be 1.2 mm and the elasticity 200 % at minus degrees temperature. Mechanical fixings and / or fixings by weight of granulate shall be applied. SBS-bitumen roofing shall be made of minimum 2 layers.

Each layer is overlapped and bonded minimum width 100 mm. First layer is fixed by mechanical fixings or by hot bitumen bond according to base material. Second layer is fixed by flame welding 100 % of area.

The top layer shall be equipped with granulate chipping on top, also in cases of protective granulate layer on the roof.



client:	REMPEC
project:	Port Reception Facility, Bar, Montenegro
title:	Functional Specification Oily Waste Treatment and Port Reception Facility

6 Specification for Electrical Works

6.1 General Requirements

All electrical equipment and installations shall be carried out in accordance with the requirements of the International Electro technical Commission Standard, European Committee for Electro technical Standardisation CENELEC and its Harmonisation Documents or equivalent National Standards.

The polarity and phase colours shall be according to the local electrical regulations. The electrical supply shall be one fused feed cable, three phase, neutral + earth.

The drawing symbols shall adhere with IEC standards.

Explosion proof is to be verified during detailed engineering.

6.2 Electrical equipment

6.2.1 Switchgears

The following requirements shall be applicable to

- main Low Voltage Switchgears of the buildings (MLVS);
- motor Control Boards (MCB);
- building Services Boards (BSB);
- uninterrupted Power Supply (UPS)

Only internationally available equipment according to IEC 947 shall be selected. The construction shall meet the requirements set in standard IEC 439-1, as well as the following.

- General supply voltage, unless stated otherwise, shall be 415/240 V, 3-phase, 50 Hz.
- The degree of the protection shall be IP 54 inside buildings and IP 55 outside.
- Switchgears (MLVS, MCB, and BSB) shall be cubicle type (fixed or withdrawable) where the main feeders and motor starters shall be placed in cabinets having segregated spaces for each feeder and starter.
- The cubicles shall have hinged doors and shall be segregated from each other, supply busbars and cable cubicles, so that it is possible to work safely in one space while the other spaces are engaged.
- Each outgoing vertical switchgear section shall have an adjacent cable compartment running the full height of the switch gear.
- Minor switchboards may be multi-box or enclosed type.
- The boards will be assembled in the factory completed with internal wiring and equipment. All wires going out from the board, up to 10 mm² cross section, will end in terminal blocks. Bigger outgoing cables will be connected directly to the device.
- Also all control wires including reserve wires shall be connected to terminal blocks.
- Metallic parts of boards shall be connected to protective earth busbars or to earth terminals.



client:	REMPEC
project:	Port Reception Facility, Bar, Montenegro
title:	Functional Specification Oily Waste Treatment and Port Reception Facility

All boards shall be equipped with 20 % auxiliary distribution output relevant to total number in use. The plant shall be equipped with preliminary switchgear equipment and/or a Main Low Voltage Switchgear MLVS where necessary.

The electrical cabinet shall as a minimum comprise the following:

- low voltage distribution;
- motor starter;
- overload protection;
- all necessary switches etc.

6.2.2 Electric Motors

All electric motors shall comply with the requirements of IEC.

Constant speed a/c. motors shall be of the induction type suitable for operation on a 3 phase supply and shall be capable of operating continuously, at rated torque, at any voltage between +5 and -10 percent of the nominal value, and nominal frequency +2 and -2 Hertz.

Motors of 0, 4 kV shall be of the squirrel cage rotor type suitable for direct-on-line starting having a starting current not greater than 6 times the full load current.

All motors shall be capable of running continuously at power not less than 10 % excess of that absorbed by the driven plant under any operating conditions. The reserve power requirements shall be added to the calculated power prior to any other adjustments e.g. high ambient temperature at site. In addition all motors of 0.4 kV shall be suitable for 10 starts per hour and motors 0, 6 kV 5 starts per hour.

Submersible pump motors shall afford a degree of mechanical protection not less than IP 68. Enclosures for other motors shall afford a mechanical protection not less than IP 54 for those installed indoor and IP 55 for those installed outdoor.

In location where is a danger of explosion shall the motors be Ex-protected. Variable speed motors rated above 15 kW shall be fitted with PTC type thermistors and all the leads of these thermistors shall be terminated inside a separate terminal box with IP 55 degree of protection, where the thermistors shall be connected in series.

All motors and starters shall be able to be controlled manually and automatically from the Control Room. Motors will be operating in an ambient temperature not exceeding 40 °C. Motor insulation shall be to class F, with the temperature rise (by resistance method) limited to 80 °C.

The motors sound pressure level shall not exceed 80 dB(A) at 1 metre. In addition, the motors shall run free from vibration and their rotors shall be perfectly balanced both statically and dynamically in an approved manner.

All motors shall be given corrosion resistant paint finishes and shall have corrosion resistant parts.

	client:	REMPEC			
	project:	Port Reception Facility, Bar, Montenegro			
	title:	Functional Specification Oily Waste Treatment and Port Reception Facility			
office: Velsen	Order: 35305	document: 0	rev.: 0	sheet: 42	of: 48

6.2.3 Electric Actuators

Electrically operated actuators for valves shall be sized to guarantee closure at the maximum possible differential pressure. The safety margin of motor power available for unseating the door shall be at least 50 percent in excess of maximum closing torque at the nominal supply voltage. The closing and opening shall not be more than 2 minutes for each operation unless otherwise specified.

The electric motors shall be class F insulated and conform to the specification with a timer rating of 15 minutes or twice the valve stroking time whichever is the longer.

A hand wheel shall be provided for emergency operation and shall be arranged such that when the hand wheel is engaged the motor shall be automatically disconnected mechanically and electrically.

6.3 Cables

Power cables of 6 kV shall be PVC insulated and sheathed type typical for underground installations. Conductors shall be of high conductivity solid aluminium. Standards IEC 502 and CENELEC HD class 2. Power cables $U < 1$ kV shall be PVC insulated and sheathed cables, with copper conductors when $A < 16$ mm² and aluminium conductors when $A > 16$ mm². Standards are IEC 502 and CENELEC HD 603-3F.

Installation power cables and control cables shall be PVC insulated and sheathed cables rated voltage 450/750 V according to IEC 227. All control cables shall consist of a suitable number of conductors of Cu 1, 5.6 mm².

Cable installation shall be done as follows:

- Cable trays shall be made with galvanised steel or aluminium, with perforations for ventilation or ladder constructed.
- The trays shall be affixed with factory made parts. Manufacturer's instructions shall apply for affixation point distances, such that deflection does not exceed 1/200 suspension length.
- Power cables shall be separated from cable trays then the instrument regulation cables. Unnecessary crossings shall be avoided by neatly laying the cables on the cable trays. The cables will be fastened with ties at bends.

Cable surface installation shall occur wherever installation rails or cable trays are not available. All cables below 1.5 m from the finished floor level, where the risk of damage is greatest, shall be covered with metallic protection. Surface mounted cables shall be affixed every 20 cm minimum, with either stove enamelled or plastic covered clips. In concrete constructions the clips will be fixed in plastic or plugs with galvanised steel screws. Expansion bolts shall be used when the bearing capacity exceeds that of the plastic clips. If there are three or more parallel cable groups, plastic covered or galvanised steel cleats shall be used. Cable clips for group cleats shall be plastic with galvanised steel screws.



client:	REMPEC
project:	Port Reception Facility, Bar, Montenegro
title:	Functional Specification Oily Waste Treatment and Port Reception Facility

Underground cables shall be installed in cable trenches approximately 0.7 m below the surface with plastic flute protection. The cables shall be imbedded in stone free soil. They shall be laid on a smooth bottomed trench and covered with approximately 200 mm of sand. A plastic caution band shall be placed above the cables, at 0.3 m depth.

6.4 Lighting

Proper lighting promotes safe working conditions, good housekeeping. Lighting is required both inside structures and outside.

For inside lighting, the fullest possible use should be made of natural lighting through windows and skylights. Architectural treatment can do much to improve natural lighting. Artificial lighting is important where many operations have to be conducted during the hours of darkness. Direct lighting from high fixtures avoids glare, while indirect lighting is useful in laboratories and offices. Fixtures should be located so as to be easy of access. Means should be provided whereby high fixtures, such as those outdoors, can be reached or such fixtures should be fitted to units that can be lowered.

In those areas of the plant where moisture may be present, lighting fixtures should be vapour-tight and dust-proof. In enclosed locations, explosion-proof fixtures are required.

Outside lighting is important, as much of the treatment plant is outdoors, and operating platforms and tank walkways are frequently used by operators. Particular attention must be given to outdoor stairways, ladders, building entrances, and outdoor equipment.

In general, indoor lighting should provide 350-450 lux in equipment rooms and 550-850 lux in offices and laboratories. Outside lighting should be in the range 20-50 lux, depending on extent of use and on safety requirements. The lighting of operating stations outdoors should provide 160-220 lux.

Emergency lighting shall be applied in process areas where a break in working lighting may cause harm for process activities. Evacuation lighting shall be installed in the areas such as stairs, corridors etc. with a minimum illumination level of 0.5 lux.

All lighting will mainly be carried with fluorescent fittings. The degree of protection for the fittings will be:

- in process rooms: IP 44;
- in technical rooms: IP 34;
- in aggressive rooms: IP 65 or Ex-protected when needed.

6.5 Earthing

The earthing in the buildings shall be carried out according to the National Standards.

	client:	REMPEC			
	project:	Port Reception Facility, Bar, Montenegro			
	title:	Functional Specification Oily Waste Treatment and Port Reception Facility			
office: Velsen	Order: 35305	document: 0	rev.: 0	sheet: 44	of: 48

7 Specification for Instrumentation and Control

7.1 General Requirements

The minimum level of the instrumentation and automation works of the treatment plant will more closely be described by the Tenderer in a Process Flow Diagram in annex K .

The instruments, cabling and equipment shall be designed, manufactured and installed to ensure the highest standard of operational reliability, suitability for the prevailing ambient conditions at the site and shall be obtained from the manufacturer who has existing adequate facilities, staff and spare parts locally for servicing and maintaining them.

Equipment shall be arranged so that individual equipment may be removed without disturbing the remaining equipment of process operation.

7.2 Measuring Equipment

The flow meter, level transmitters and analysers are part of the packaged units, see table 7 to 12. Note that not all instrument types are indicated

7.2.1 Electromagnetic flow meter

The electromagnetic flow meters shall comply with the following specifications:

Number:	(*) according to Vendor specification
Temperature range:	-2 ... +50 °C
Method of measurement:	electromagnetic flow meter
Measuring range:	according to design
Accuracy:	< ±0.5 % of measured value
Repeatability:	< ±0.1 % of measured value
Output signal:	4 - 20 mA, galvanically isolated
Protection:	IP 65
Power supply:	240 VAC, power feed from nearest distribution board
Other devices:	display in six numbers for actual and cumulative flow indication in [m ³ /h]
Installation:	according to design

7.2.2 Ultrasonic flow meter

The ultrasonic flow meters for closed conduits shall comply with the following specifications:

Number:	(*) according to Vendor specification.
Temperature range:	-2 ... +50 °C
Method of measurement:	ultrasonic flow meter
Measuring range:	according to design
Accuracy:	< ±0.5 % of measured value
Repeatability:	< ±0.1 % of measured value
Output signal:	4 - 20 mA, galvanically isolated
Protection:	IP 65
Power supply:	240 VAC, power feed from nearest distribution board

Other devices: display for actual and cumulative flow indication in m3/h
Installation: according to design

7.2.3 Ultrasonic level meter

The ultrasonic level meters shall comply with the following specifications:

Number: (*) according to Vendor specification
Method of measurement: ultrasonic level meter or for flow in open conduits
Temperature range: -2 ... +50 °C
Measuring range: according to design
Accuracy: < ±0.5 % of measured value
Repeatability: < ±0.1 % of measured value
Response time: < 10 sec.
Output signal: 4 - 20 mA, galvanically isolated
Protection: IP 65
Power supply: 240 VAC, power feed from nearest distribution board
Other devices: display for actual and cumulative flow indication in m3/h
Installation: according to design

7.2.4 Piezoresistive pressure level meter

The piezometric level meters shall comply with the following specifications:

Number: (*) according to Vendor design
Method of measurement: piezoresistive pressure transducer
Temperature range: -2 ... +50 °C
Measuring range: according to design
Accuracy: < ±0.5 % of measured value
Repeatability: < ±0.1 % of measured value
Response time: < 1 sec.
Output signal: 4 - 20 mA, 2-wire
Protection: IP 65
Power supply: 240 VAC, power feed from nearest distribution board
Other devices: display for actual level indication in [m]. Three (3) limit switch units with two (2) changeover outputs relay per unit.
Installation: according to design

7.2.5 Level switches

The level switches shall be of floating type switches. The level switches shall operate on 24 V dc voltage.

7.2.6 IR Spectrometer

The infrared spectrophotometer shall comply with the following specifications:

Number: 1
Method of measurement: absorbance in solutions
Measuring range: 200-850 nm
Optical resolution: about 1.5 nm
Output signal: USB port for use at Windows 98SE/2000/XP

Power supply: 240 VAC, power feed from nearest distribution board
Installation: in laboratory

7.2.7 Water in oil

The capacitance probe oil in water analyser for measuring the percentage of free emulgated water in oil shall comply with the following specifications:

Number: (*) according to Tenderer's design
Method of measurement: capacity
Measuring range: (*) according to Tenderer's design
Output signal: 4 - 20 mA, 2-wire
Power supply: 240 VAC, power feed from nearest distribution board
Installation: in laboratory

7.2.8 Design

All field instruments shall be IP55-enclosed and equipped with tagged nameplates. Tag numbers to be supplied by Owner. Accuracy must be at least 1% full scale. The instruments shall operate on 24 VDC. The power supply to Tenderer will be 220/230-380/400V, 50 Hz. All instruments shall be lined-up completely with ½' steel impulse lines using compression type fittings. Used bracket material shall be steel.

All instruments using instrument air shall be supplied with filter/pressure reducer and air supply pipeline. The sub air header shall be furnished with a shut-off valve to the main air header.

All instruments will be electrically connected via an IP54-enclosed instrument junction box towards the fully wired local control panel. All single cable shall run between each skid and the control panel. The cables shall be numbered according to the instrument tag numbers.

The local panel shall be furnished with all the lamps, push buttons and indicators/controllers for all applied instruments. The interface to the 'plant control system' consists of a 'system failure' all tendered (potential free) via a terminal in the local panel.

Measurement units shall to be according to SI standards.

All process information shall be connected to programmable logic controller (PLC). The PLC shall control all the process equipment. The PLC shall be installed in a separate (air conditioned) control room.

From all equipment which shall be controlled by the PLC shall be connected the minimum information to the PLC as follows:

- position of the control switch: 2xDI (digital input)
- run information: 1xDI
- alarm information: 1xDI
- control: 1xDO (digital output)



client:	REMPEC
project:	Port Reception Facility, Bar, Montenegro
title:	Functional Specification Oily Waste Treatment and Port Reception Facility

The PLC shall be in compliance with the following technical requirements:

- modular structure for enlarging;
- EEPROM or adequate memory backup;
- on-line programming;
- real time clock;
- real time calendar;
- serial RS 232 C interface for radio modem for data communications;
- serial RS 232 C interface for PC (for monitoring the state of technological process, changing control values and programming PLC);
- built-in communication software;
- One common alarm..

The Contractor shall provide an instrumentation earthing system. Each instrumentation system or group of instruments shall be connected individually to this earthing via insulated copper earth cables sized for the maximum prospective fault current. This earthing system shall be independent and shall not form part of the general plant earthing system.

7.3 Automation Works

Under regular circumstances the process shall be controlled automatically by control system with no operating staff. Alarm points shall be programmable to three alarm emergency classes. The PLC shall bear the readiness for the remote control by the central computers later on.

All equipment and measuring instruments connected to the local automation system shall be equipped with possibility to be monitored on the graphic display for supervision. All measuring and set points shall be ready for monitoring in pre-programmed trend displays.

The PLC shall be equipped with power system to retain the software and operation readiness during the power failures and the system shall be designed so that after the cut-off the plant shall start automatically.

Normal voltage 240 V AC, 50 Hz, shall be fed to the PLC.

The basic functions of the PLC program are as follows:

- controlling the process;
- calculating the running time of the machines;
- counting the number of starts and stops;
- calculating/counting the flows;
- calculating the energy consumption;
- generating the alarm signals;
- processing the data storage;
- data communication with the control system;
- visualisation of the process.



client:	REMPEC
project:	Port Reception Facility, Bar, Montenegro
title:	Functional Specification Oily Waste Treatment and Port Reception Facility