



IMO-OMI



UNEP-PNUE

**REGIONAL MARINE POLLUTION EMERGENCY  
RESPONSE CENTRE FOR THE MEDITERRANEAN SEA  
(REMPEC)**

**EURO-MED PARTNERSHIP**



EU - UE



**PROJECT MED.B4.4100.97.0415.8**

**PORT RECEPTION FACILITIES FOR COLLECTING  
SHIP-GENERATED GARBAGE,  
BILGE WATERS AND OILY WASTES**

**ACTIVITY D**

**STANDARD DESIGNS FOR  
(A) OILY WASTES RECEPTION, TREATMENT, STORAGE  
AND DEWATERING FACILITIES  
AND (B) GARBAGE COLLECTION, TREATMENT AND  
DISPOSAL FACILITIES**

**FINAL REPORT**

**October 2004**



**TEBODIN**  
Consultants & Engineers

The present document and related study have been produced with the financial assistance of the European Community. However, the views expressed herein should in no way be taken to reflect the official opinion of the European Community (EC).

This study was executed by Tebodin Consultants & Engineers, The Netherlands, contracted by and under the responsibility of the Regional Marine Pollution Emergency Response Center for the Mediterranean Sea (REMPEC).

The designations employed and the presentation of the material in this publication do not imply the expression of any opinion whatsoever on the part of EC, IMO, UNEP, MAP and REMPEC concerning the legal status of any State, Territory, city or area, or its authorities, or concerning the delimitation of their frontiers or boundaries.

**Port reception facilities for collecting  
ship-generated garbage, bilge water and  
oily wastes-MED.B7.4100.97.0415.8**

**Activity D – Standard designs**

client REMPEC

project Activity D - Standard designs

order number 33202

document number 3312001

revision 0

date 3 September 2004

author M. Hess, A. Snuverink, A.Schoof, A.M de Leeuw

**Tebodin B.V.**

Laan van Nieuw Oost-Indië 25  
2593 BJ The Hague  
P.O. Box 16029  
2500 BA The Hague  
the Netherlands

telephone +31 70 348 03 47  
telefax +31 70 348 05 16  
e-mail a.deleeuw@tebodin.nl

0	03-09-2004	For comments	A.M de Leeuw	A. Schoof
rev.	date	description	author	ckd.

---

<b>Table of contents</b>		page
<b>1</b>	<b>Introduction</b>	<b>4</b>
1.1	Level of detail	4
1.2	General project background	5
<b>2</b>	<b>How to use the documents</b>	<b>7</b>
2.1	Utilization as part of a comprehensive Design Package	7
2.2	Utilization for direct quotation by Contractors	7
<b>3</b>	<b>Which document to use</b>	<b>9</b>
3.1	Recommendations for individual ports	10
<b>4</b>	<b>General tendering information</b>	<b>11</b>
4.1	FIDIC tendering procedures	11
4.2	Typical table of contents	12
4.3	Locally produced goods	13
<b>Appendix A: Functional specification for oily waste treatment plants in port reception facilities</b>		<b>14</b>
<b>Appendix B: Functional specification for Transfer Stations of Garbage</b>		<b>15</b>
<b>Appendix C: Technical drawings for Oily waste treatment in Port reception facilities</b>		<b>16</b>
<b>Appendix D: Technical drawings for Transfer Stations of Garbage</b>		<b>17</b>
<b>Appendix E: Overview of Technical Codes and Standards</b>		<b>18</b>

---

## 1 Introduction

Attached to this covering report you will find standard design documents for port reception facilities and waste treatment plants to be used for collection, treatment and disposal of garbage, bilge waters and oily residues from ships calling at ports.

All information presented in the attached documents is made available for the Mediterranean Coastal States for further implementation in their ports, i.e. the construction of port reception and treatment facilities. To that end, tenders can be launched to invite bids from contractors for supply of equipment and for executing the construction works. Each country may follow its own tendering policy and procedures according to their respective national legislation and/or practice. Drawings and functional specifications have been created with the aim of their (potential) use in tendering packages and the documents are considered suitable to contract bids for supply of equipment. The documents attached can be used free of charge and are not copyright protected.

The documents attached are:

1. functional specifications for oily waste treatment in port reception facilities (appendix A);
2. functional specifications for transfer stations of garbage (appendix B);
3. technical drawings for oily waste treatment in port reception facilities (appendix C);
4. technical drawings for transfer stations of garbage (appendix D).

### 1.1 Level of detail

In most circumstances, the documents attached will be incorporated in a more elaborate and comprehensive Tender Package. For this, local situations and circumstances might give rise to alterations or even removal of less irrelevant or non applicable paragraphs from the functional specifications which are presented in attachment A and B of this report. Documents concerning e.g. 'Instructions to tenderers' and 'General contract conditions' need to be amended to the documents attached in order to make it a complete Tender Package. A draft table of contents of a comprehensive Tender Package is presented in paragraph 4.2.

The documents attached however, do not comprise tender documents for (turn-key) construction of port reception and treatment facilities. The information presented in reports preceding this Activity D report, does not have the appropriate level of detail to prepare harbor specific tender documentation.

Examples in this respect are e.g.:

- construction of port reception facilities will require civil works, but as long as the site for the facilities has not been determined, it is not possible to finalize the site layout, to specify the necessary civil works and to produce an exact bill of quantities;
  - power supply may or may not be existing and/or have sufficient capacity;
  - waste collection services to the ships are the responsibility of a port authority, but in many cases **executed** by a local private company to which these services are contracted. In these cases it may not be necessary to purchase new trucks or barges, even if collection services are not provided in a port in the present situation.
-

To summarize it all: local circumstances may greatly affect by the authority the final Scope of Work for suppliers of equipment and contractors depending the local institutional setting.

Another issue is that a Tender Package logically contains a Technical Part and an Administrative Part. Since every country will follow its own tendering procedures the Administrative Part should be tailor made and can therefore not be presented as a standard document.

The equipment included and presented in the attached documents is available from a variety of suppliers. However, each supplier uses its own specific features and technical details, and most treatment equipment might be procured as a package unit. We have therefore limited the level of detail of the attached documents. However the level of detail is:

- sufficient to ensure proper performance of the facilities;
- not too specific that it would narrow down the number of (potential) suppliers and would obstruct international competitive bidding.

In the following chapters you will find detailed instructions on the utilization of the documents supplied, general project background and additionally some recommendations concerning tendering procedures.

## **1.2 General project background**

This specific Activity D project is part of the larger Meda project on port reception facilities for collecting ship generated garbage, bilge water and oily wastes in the Mediterranean (Project MED/B7/41 00/97/0415/8).

The implementation of MARPOL 73/78 Convention for the prevention of pollution from illegal discharges into the sea is one of the main concerns relating to prevention of the pollution from ships in the Mediterranean Sea. Even though accidental marine pollution still attracts major public attention, operational pollution by illegal discharges into the sea is the main source of pollution by ships of the marine environment. This is particularly true as regards the Mediterranean Sea, a particularly sensitive area in terms of chronic pollution due to the geographical, oceanographic and ecological specificities of the area.

In addition to operational oil pollution, the MARPOL Convention also addresses pollution by chemicals, substances carried in packaged form, sewage, garbage and air pollution from ships. According to the provisions of Annex I and Annex V of MARPOL, the Mediterranean Sea is defined as a 'special area', where more stringent measures for the prevention of operational pollution are applied. Ships are not, therefore, allowed to discharge oil or garbage into the Mediterranean Sea, and thus:

- ships are requested to retain on board and treat such wastes, and;
- the wastes and residues have to be discharged into adequate reception facilities provided by States in their ports and terminals.

While significant improvement has been reached in ship design and equipment which permits retention on board of residues, the requirement concerning the transfer of residues to reception facilities on shore is not fulfilled due to the lack of adequate reception facilities in certain ports and terminals of the Mediterranean.

---

It is recognized that the establishment of adequate port reception facilities has to be given due consideration by competent national administrations, especially when considering recent developments in new ports in the Mediterranean region, as it is agreed that the developments in respect of national regulations in the field of prosecution for illegal discharges can only be found justified if possibility is given to the masters to use adequate port reception facilities.

Mediterranean coasts are still suffering from a serious lack of adequate port reception facilities for collecting ship-generated wastes, despite the fact that Annex I and Annex V of MARPOL 73/78 entered into force in 1983 and in 1988 respectively. Solving this problem calls for close cooperation among all Mediterranean coastal States and for a joint action that cannot be further postponed.

A technical assistance project funded by the MEDA financial mechanism of the European Commission was granted to the Regional Marine Pollution Emergency Response Centre for the Mediterranean Sea (REMPEC), on behalf of the International Maritime Organization (IMO), for the implementation of MARPOL 73/78 as regards to port reception facilities for collecting ship-generated garbage, bilge waters and oily wastes.

The Project involves ten Mediterranean countries: Algeria, Cyprus, Egypt, Israel, Lebanon, Malta, Morocco, Syria, Tunisia and Turkey and has been conceived to comprise five activities:

1. Activity A: Identifying the required capacities for collection and treatment of relevant types of solid and liquid wastes.
2. Activity B: Study concerning optimum solutions for collecting, treatment and disposal of relevant types of ship generated solid and liquid wastes.
3. Activity C: Identifying the required capacities for collection and treatment of oily ballast waters from tankers.
4. Activity D: Preparation of standard designs for port reception facilities.
5. Activity E: Regional Seminar.

Activities A and C aimed at assessing, by project-consultants and national experts, the present situation in these countries concerning port reception facilities and at identifying required capacities for collection and treatment of relevant types of solid and liquid wastes and oily ballast waters from tankers, taking into consideration the type and capacity of existing installations and specific nature of traffic in each country and port concerned, as well as specific requirements resulting from such differences. The implementation of these two activities has been completed. The results of abovementioned two activities provided the basis for Activity B which consisted of the preparation of a study concerning optimum solutions for collecting, treatment and disposal of relevant types of ship generated solid and liquid wastes. This Activity B has also been completed. The present Activity D report deals with the preparation of standard designs for port reception facilities and waste treatment plants, for collection, treatment and disposal of garbage, bilge water and oily residues, that are made available free of charge, to all Mediterranean coastal States, for implementation in their ports.

At the end of the Project, a Regional Seminar (Activity E) will be organized, bringing together all parties involved, to discuss the results of the Project and to recommend a course of action for future implementation.

---



## 2 How to use the documents

The documents presented in the appendices attached can be used in two different ways:

- as part of a comprehensive Design Package;
- as bid document for direct quotation by Contractors.

Both ways of utilizing the documents attached is elucidated in more detail in sections 2.1 and 2.2.

Many different tendering procedures can be applied. In general terms and based on our experience in Mediterranean and Arabic countries it can be stated that the 'FIDIC ©<sup>1</sup> conditions' (Green Book - Short Form of Contract - and Yellow Book – Plant and Design-Build Projects) are recommended as basis for Employers tendering procedures, being Employers best guarantee to timely and budgetary completion of projects. In chapter 4 some key features of the FIDIC tendering procedure are presented.

### 2.1 Utilization as part of a comprehensive Design Package

In case the functional specifications and the design drawings attached are used as part of a comprehensive Design Package (or Project Development Package) the actual parameters of the project (like volumes of waste to be disposed of, type of waste, method of disposal, etc) need to be specified and the equipment might need to be resized.

Tenderers may decide to use the given parameters by this functional specification and the corresponding results of the 'Rempec'-reporting under Activities A, B and C in their own tendering procedures (either public announcement, using European Bidding Rules or using FIDIC conditions) This can be done either for a large-scale development program, an international development program, or only for the scale of the scope of work as described in this specification and limited to the specific location.

### 2.2 Utilization for direct quotation by Contractors

Secondly the documents can be utilized as technical bid documents for direct quotation by Contractors, using the given sizing in these specifications for each location, or alternatively defining the parameters to the local requirements and "size" the equipment or services to be offered/supplied on the basis of the principles as presented in these functional specifications and technical drawings.

In this case Contractors may decide how to interpret the contents of these specifications and technical drawings; however, they should restrict themselves to the 'sizing' of the given solutions in these documents (parameters per location).

These specifications shall preferably be quoted for only on the basis of an 'Open-Estimate' and NOT on a 'lumpsum-turnkey bases. The reason for this is that the solutions described, local circumstances and equipment requirements will differ for each location considerably and the various components as described for each port may not be available locally. Consequently one selected local supplier/contractor might have difficulties supplying the required equipment. Tenderers might split bidding over several sub-suppliers and equipment manufacturers.

---

<sup>1</sup> FIDIC © - Fédération des Ingenieurs-Conseils - International Federation of Consulting Engineers

Tebodin recommends 'lumpsum-turnkey' bidding only after careful and comprehensive pre-qualification of tenderers, towards their capability in fulfilling Employers tendering procedures, verification of financial soundness, and understanding of the complexity of the specifications and their solvability for the duration of the project. Furthermore Employer should review tenderers resources and mechanical equipment, quality and safety records and their engineering capacities.

### 3 Which document to use

The design concept of the Oily Waste Treatment Facilities is modular. For these modules, three different model capacities were elaborated. The general contents of the specifications to be prepared do not depend on the design treatment capacity, other than that the correct figures (tank volumes, treatment capacities, etc.) must be filled in.

For the garbage transfer stations drawings for three capacities were elaborated.

Table 3.1 shows a selection table that can be used by the ports involved. With this table the ports can select the applicable drawings that have to be attached to the functional specifications in their Tender Package.

**Table 3.1: Selection table for technical drawings to be included in the Tender Package**

		Oily Waste		Garbage	
		Module <sup>1)</sup>	Drawings	Capacity <sup>2)</sup>	Drawings <sup>7)</sup>
Algeria	Algiers	A-I B-I <sup>3)</sup> C-1 <sup>3)</sup>	1342005 sheet 1 and 1342010 1342005 sheet 2 <sup>4)</sup>	n.a.	
	Arzew & Bethioua	A-I B-I <sup>3)</sup> C-1 <sup>3)</sup>	1342005 sheet 1 and 1342010 1342005 sheet 2 <sup>4)</sup>	n.a.	
	Skikda	A-III B-III <sup>3)</sup> C-III <sup>3)</sup>	1342007 sheet 1 and 1342011 1342007 sheet 2 <sup>4)</sup>	M	33002051
Egypt	Alexandria & Dhekelia	A-I B-I <sup>3)</sup> C-1 <sup>3)</sup>	1342005 sheet 1 and 1342010 1342005 sheet 2 <sup>4)</sup>	L	33002052
	Port Said	A-I B-I <sup>3)</sup> C-1	1342005 sheet 1 and 1342010 1342005 sheet 2 <sup>4)</sup>	n.a.	
Israel	Hadera	<sup>5)</sup>		n.a.	
Lebanon	Beirut	A-I C-1	1342005 sheet 1 and 1342010 <sup>4)</sup>	n.a.	
	Tripoli	A-I C-1	1342005 sheet 1 and 1342010 <sup>4)</sup>	n.a.	
Morocco	Nador	A-I C-1	1342005 sheet 1 and 1342010 <sup>4)</sup>	n.a.	

Port reception facilities for collecting ship-generated garbage, bilge water and oily wastes - Activity D

		Oily Waste		Garbage	
		Module <sup>1)</sup>	Drawings	Capacity <sup>2)</sup>	Drawings <sup>7)</sup>
Syria	Banias	A <sup>6)</sup>		n.a.	
	Tartous Oil Terminal	B-III <sup>3)</sup> C-III <sup>3)</sup>	1342007 sheet 2 <sup>4)</sup>		
	Tartous	A-I B-I <sup>3)</sup> C-1	1342005 sheet 1 and 1342010 1342005 sheet 2 <sup>4)</sup>	n.a.	
Tunisia	La Goulette	A-I B-I <sup>3)</sup> C-1	1342005 sheet 1 and 1342010 1342005 sheet 2 <sup>4)</sup>	n.a.	
	Sfax	A-I B-I <sup>3)</sup> C-1	1342005 sheet 1 and 1342010 1342005 sheet 2 <sup>4)</sup>	n.a.	
Cyprus	Limassol	n.a.		L	33002052
Malta	Valetta	n.a.		L	33002052
Turkey	Bodrum	n.a.		M	33002051

**Notes referring to Table 3.1:**

<sup>1)</sup>	Module A: oily water treatment; Module B: slop oil treatment; Module C: residual sludge treatment.
<sup>2)</sup>	The sizing of the garbage transfer station is divided according three ranges of capacities: Small (S): <1000 m <sup>3</sup> /a; Medium (M): 1000-2000 m <sup>3</sup> /a; Large (L): >2000 m <sup>3</sup> /a.
<sup>3)</sup>	Not required according the findings of Activity B. Based on the possibly changing local situation and circumstances the port authorities could consider to implement this type of treatment as the standard design including drawings are also provided within this standard design package for your information.
<sup>4)</sup>	A description of the residual sludge treatment, with the principal dimensions can be found in section 4.3 of the Functional Specification for Oily Waste Treatment.
<sup>5)</sup>	As oily water treatment is not needed only a reception tank is proposed; no drawings are included.
<sup>6)</sup>	In this case a special designed common plant is required based on Module A; no drawings are included.
<sup>7)</sup>	The applicable garbage transfer capacities comprise medium and large sized transfer stations. In case of smaller garbage transfer demand reference is made to standard design represented by drawing nr. 33002050.
n.a.	not applicable

### 3.1 Recommendations for individual ports

The reports on Activity A and B also provide recommendations for several individual ports. Appropriate implementation of these recommendations requires a detailed assessment of the local situation by means of site visits and inspections.

## **4 General tendering information**

A Tender Package has to be in line with the nature of the project and the character of the Employers organization, not in the last place when it is a project 'for and on behalf of the Employer'. Of course it must also comply with (inter)national legal standards and practices.

### **4.1 FIDIC tendering procedures**

Next to other tendering methodologies FIDIC regulations have demonstrated to gain good results in Mediterranean and Arabic countries. FIDIC makes distinctions between four different Tender Packages aimed to be selected from in order to fit Employers requirements best.

#### **Green Book**

These Conditions of Contract are recommended for engineering and building work of relatively small capital value. However, depending on the type of work and the circumstances, the Conditions may be suitable for contracts of considerably greater value. They are considered most likely to be suitable for fairly simple or repetitive work or work of short duration without the need for specialist sub-contracts. This form may also be suitable for contracts which include, or wholly comprise, contractor-designed civil engineering, building, mechanical and/or electrical works.

#### **Yellow Book**

Conditions of Contract for Plant and Design-Build, which are recommended for the provision of electrical and/or mechanical plant, and for the design and execution of building or engineering works. Under the usual arrangements for this type of contract, the Contractor designs and provides, in accordance with the Employer's requirements, plant and/or other works; which may include any combination of civil, mechanical, electrical and/or construction works.

#### **Silver Book**

Conditions of Contract for EPC Turnkey Projects, which are recommended where one entity takes total responsibility for the design and execution of an engineering project. Under the usual arrangements for this type of contract, the entity carries out all the Engineering, Procurement and Construction: providing a fully-equipped facility, ready for operation (at the 'turn of the key'). This type of contract is usually negotiated between the parties.

#### **Red Book**

Conditions of Contract for Construction, which are recommended for building or engineering works designed by the Employer or by his representative, the Engineer. Under the usual arrangements for this type of contract, the Contractor constructs the works in accordance with a design provided by the Employer. However, the works may include some elements of Contractor-designed civil, mechanical, electrical and/or construction works.

For the garbage transfer stations the Green Book (Short Form of Contract) is recommended, because of the relatively small contract price and because it is a relatively simple project.

For the oily waste treatment facilities the Green Book or Yellow Book (Conditions of Contract for Plant and Design-Build) is recommended.

---

## 4.2 Typical table of contents

Based on FIDIC tendering procedures a complete set of Tender Documents would comprise the following volumes and sections. It should be noted that this is a typical table of content whereas the scope and extent of the project could be such that specific sections are not required or other deviations should be made. It remains the duty and the responsibility of the port authorities to consider and decide upon the content of the tender documents.

### Invitation to Tender (cover letter)

#### Volume I:

1. Instructions to Tenderers;
2. Form of Tender;
3. Appendix to Form of Tender;
4. Form of Breakdown of Price;
5. Specimen of Tender Bond/Security;
6. Qualifications Forms;
7. Form of Contract Agreement;
8. Form of Performance Guarantee;
9. Form of Advance Payment Guarantee;
10. Applicable Standards.

#### Volume II:

Part I: General Conditions of Contract (e.g. Green or Yellow Book).  
Part II: Conditions of Particular Application.

#### Volume III a: Functional Specification Oily Waste Treatment (appendix A);

1. General Requirements;
2. Description of the Works;
3. General Specifications;
4. Specification for Mechanical Works;
5. Specification for Civil Works;
6. Specification for Electrical Works;
7. Specification for Instrumentation and Control;
8. Exclusions from Delivery.

#### Volume III b: Functional Specification Garbage Treatment (appendix B)

1. General Requirements;
  2. Description of the Works;
  3. General Specifications;
  4. Specification for Mechanical Works;
  5. Specification for Civil Works;
  6. Specification for Electrical Works;
  7. Specification for Instrumentation and Control;
  8. Exclusions from Delivery.
-

**Attachments:**

I: Drawings (appendices C and D);

II: Requisitions.

### **4.3 Locally produced goods**

It may (or may not) be possible to purchase main equipment (tanks, piping) manufactured by local suppliers. This does not have any effect on the design of the facilities, but it can have a significant impact on the tendering procedure, contracting strategy and of course costs. For example: if storage tanks can be manufactured locally (but not the treatment equipment) and if it is preferred to purchase locally, it may be required to separately tender the design, delivery and construction of the tanks. This then also requires evaluating separate bids and to supervise and manage several suppliers and contractors during the construction stage. We recommend the following approach:

- not to distinguish between local and international suppliers/contractors in the design stage;
- when launching tenders, to ensure that it is included in the tender documents that locally manufactured goods are preferred;
- to prepare a list of interested local manufacturers as information for international contractors.

Furthermore it is noted that 'local bidding' may give fast solutions to local waste issues and should prevail when real urgency is experienced.

## **Appendix A: Functional specification for oily waste treatment plants in port reception facilities**

- document number 3181001, rev. A.



## Functional Specification for Oily Waste Treatment in Port Reception Facilities

B	01-10-2004	Comments Rempec	M. Hess	A.de Leeuw
A	04-09-2004	Updated	M. Hess	A. de Leeuw
0	28-08-2004	For Quotation/Comments		
rev.	date	description / issued for	author	ckd.
	client:	REMPEC		
	project:	Port Reception Facilities		
	title:	Functional Specification Oily Waste Treatment		
office: Hengelo		Order: 33202	document: 3181001	rev.: B sheet: 1 of: 49

<b>Table of contents</b>	<b>page</b>
<b>Definitions</b>	<b>5</b>
<b>1 General Requirements</b>	<b>6</b>
1.1 Introduction	6
1.2 Tenders	7
1.3 Information	8
1.4 Coordination and Inspections	8
<b>2 Description of the Works</b>	<b>9</b>
2.1 Modules	9
2.2 Design Basis	10
2.3 Guarantees	11
2.4 Detailed Design	11
2.5 Inspections	12
<b>3 Employer's Requirements</b>	<b>13</b>
3.1 Module A (reception and treatment facilities)	13
3.1.1 Reception and holding tanks	13
3.1.2 Oil removal	14
3.2 Module B (slop oil dewatering facilities)	15
3.3 Module C (sludge treatment facilities)	15
<b>4 Technical Requirements</b>	<b>17</b>
4.1 Modules for Tendering	17
4.2 Design Objectives	18
4.2.1 Module Specification	19
4.2.2 Removal efficiencies	19
4.3 Lagoon design	20
<b>5 General Specifications</b>	<b>25</b>
5.1 Responsibility	25
5.2 Standards and Regulations	25
5.3 General Requirements	26
5.4 Documentation	26
5.4.1 Manufacturing report	26
5.4.2 Documents for regulatory approvals by relevant authorities	27
5.4.3 As-built drawings	27
5.4.4 Manuals	27
5.4.5 Submittal, review and approval of documents	28
5.4.6 Other instructions for documents	29
5.5 Quality Requirements, Testing	29
5.6 Commissioning and Take Over	29
5.7 Training for operation and maintenance	30
5.7.1 General	30
5.7.2 Training Programme	30

5.7.3 Contractor's Training Personnel	30
5.7.4 Facilities and Location for Training	31
5.7.5 Safety Training	31
5.7.6 Language for Training	31
<b>6 Specification for Mechanical Works</b>	<b>32</b>
6.1 General Requirements	32
6.2 Tanks	32
6.3 Pumps	33
6.4 Pipes	33
6.5 Valves	34
6.6 Corrosion Protection, Painting	35
6.7 Noise requirements	36
6.8 Maintenance	37
<b>7 Specification for Civil Works</b>	<b>38</b>
7.1 General Requirements	38
7.2 Demolition works	38
7.3 Earthworks	38
7.3.1 Excavations	38
7.3.2 Supporting the Excavations	38
7.4 Concrete and reinforcements	38
7.4.1 Water Proof Concrete	39
7.4.2 Reinforcement	39
7.4.3 Water retaining structures	39
7.4.4 Finishing of Concrete Surfaces	40
7.4.5 Brick and concrete block work	40
7.5 Roofing	40
<b>8 Specification for Electrical Works</b>	<b>42</b>
8.1 General Requirements	42
8.2 Electrical equipment	42
8.2.1 Switchgears	42
8.2.2 Electric Motors	43
8.2.3 Electric Actuators	44
8.3 Cables	44
8.4 Lighting	45
8.5 Earthing	45
<b>9 Specification for Instrumentation and Control</b>	<b>46</b>
9.1 General Requirements	46
9.2 Measuring Equipment	46
9.2.1 Flow meters	46
9.2.2 Electromagnetic flow meter	46
9.2.3 Ultrasonic flow meter	47
9.2.4 Ultrasonic level meter	47
9.2.5 Piezoresistive pressure level meter	47

9.2.6 Level switches	48
9.2.7 Design	48
9.3 Automation Works	49



client:	REMPEC
project:	Port Reception Facility
title:	Functional Specification Oily Waste Treatment

## Definitions

The following notes and expressions in this specification shall have the meaning hereby assigned to them for the purpose of this request except where the context otherwise requires:

**'Government'** means the Government of ..... and its authorised agents.

**'Employer'** means the National Organisation issuing the Tender Documents for these works.

**'Works'** and **'Permanent Works'** means all Plant to be provided and all work to be executed in accordance with the Contract including if necessary the design, manufacture, delivery, supply, erection, construction setting to work, commissioning, testing, operation and maintenance.

**'Temporary Works'** means all temporary works of every kind required in or about the execution of the Works.

**'Specification'** means the technical specification according to which the works are to be executed referred to in the Contract Documents and any other specification agreed thereon.

**'Tenderer'** means the Company who delivers a proposal on behalf of this invitation for tendering.

**'Contractor'** means the person or persons, firm or company whose proposal has been accepted by the Employer and includes the Tenderer's authorised representatives, successors and permitted assigns.

**'Sub-Contractor'** means any person or persons, firm or company entering into an agreement with the Contractor for performance of work under this Assignment.

**'Terms of Reference'** (ToR) means the statement issued by the Employer giving the definition of its requirements and objectives of the services, including, where applicable, the methods and means to be used and/or results.

**'Schedule'** means the Schedule or Schedules in which the Works are described for the purpose of evaluating the items of the Works to be executed under the Assignment by the Contractor.

**'Site'** means the land and other places, on, under, in or through which the Works are to be executed or carried out and any other lands or places provided by the Employer for the purposes of the assignment together with such other places as may be specifically designated in the Contract as forming part of the Site.

Words implying persons or parties shall include firms and corporations. Words implying the singular only also include the plural and vice versa where the context requires.

	client:	REMPEC			
	project:	Port Reception Facility			
	title:	Functional Specification Oily Waste Treatment			
office: Hengelo	Order: 33202	document: 3181001	rev.: B	sheet: 5	of: 49

# 1 General Requirements

## 1.1 Introduction

The implementation of MARPOL 73/78 Convention for prevention of pollution from illegal discharges into the sea is one of the main concerns relating to prevention of the pollution from ships in the Mediterranean Sea. Even though accidental marine pollution still attracts major public attention, operational pollution by illegal discharges into the sea is the main source of pollution by ships of the marine environment.

The IMO/UNEP Regional Marine Pollution Emergency Response Centre for the Mediterranean Sea (REMPEC), a Regional Activity Centre within the Mediterranean Action Plan (MAP) of the United Nations Environment Program (UNEP) administered by the International Maritime Organisation (IMO), is currently implementing an EU funded MEDA Project on port reception facilities for collecting ship-generated garbage, bilge waters and oily wastes in the Mediterranean (MED.B7.410097.0415.8). This project contains several activities.

Activities A and C assessed the present situation of port reception facilities in the involved countries, while Activity B presented the solution for collection, treatment and disposal of relevant types of ship generated solid and liquid waste for a number of relevant ports/terminals. That report compiled experience about port reception facilities in many ports worldwide as well as waste management techniques (BAT – Best Available Techniques).

This Technical Specification, Activity D of the project, represents the functional specification of the required facilities in the relevant ports.

Collection of wastes from ships is in many ports done by private contractors. In a number of ports additional collections means as trucks and barges are recommended in the reports of activity A and C. Any modification or extension of collection activities is no subject to this specification.

This technical specification, Activity D of the Project, was developed with the objective that the National Organisation issuing the Tender Documents, hereunder referred to as the 'Employer', either finances the construction of the facilities, or seeks funding from donor agencies and financial institutions for the setting up of facilities for the reception and treatment of oily wastes in typical facilities with standard holding volumes and treatment capacities.

The cost of building/constructing reception facilities will include the costs of the material purchased from overseas under Design-Built type contract, as well as additional works conducted locally for the entire reception and treatment facilities. These Employers Requirements will concern the modules to be delivered and the work to be conducted for the realization of the entire reception and treatment facility for oily waste in the relative ports.



client:	REMPEC
project:	Port Reception Facility
title:	Functional Specification Oily Waste Treatment

## 1.2 Tenders

It is the intention of the Employer to place a Contract at later stage for the whole or a part of the works in accordance with a Tendering package, in which detailed duty specifications have been developed on the basis of these functional specifications or a after bidding on basis of this specification alone.

For this purpose the Employer issues the 'Operational and Functional Design Criteria' of the project in this Functional Specification.

The scope of services and supply shall comprise, but is not limited to, the following:

- the detailed design, construction, supply and installation, process start-up and testing for operation parameters and handing over to the Employer a complete, reliable, safe and operational system including all items, services and documents except those specifically indicated as 'Exclusion' in paragraph 5 (Technical Requirements);
- a complete detailed description of each part of the equipment offered;
- a description of the design principles and the materials of construction;
- quality and safety objectives and operational conditions;
- the method of operation;
- the relevant standards applicable to the design;
- listing of applicable international and local law pertaining the complexity of the plant and environmental conditions;
- a complete set of performance data and characteristics;
- a computation of equipment capacities and sizing where required;
- a list of particular process guarantees;
- a complete set of drawings;
- a training schedule for the Employers personnel in operation and maintenance;
- a time schedule for completion.

The Tenderer is required to submit a Tender which fully complies with all volumes of this Specification. To comply with this requirement the Tenderer must fully understand the Specification which includes the Conditions of Contract.

On the condition that a Tender is submitted in accordance with the above, the Tenderer may submit for consideration an alternative Tender incorporating an alternative technical proposal. The alternative proposal must be submitted as an alternative Tender and the departures from the specified requirements must be clearly stated. The Tenderer shall also state his reasons for proposing such deviations. The departures shall be individually priced which shall enable the Employer at his option to adjust the Tender price where he considers any particular departure to be acceptable.



client:	REMPEC
project:	Port Reception Facility
title:	Functional Specification Oily Waste Treatment

### 1.3 Information

The Tenderer should inspect the Site and its surroundings and have to satisfy himself completely before submitting his Tender as to the nature of the ground and sub-soil, the hydrological and climatic conditions, the form and nature of the site, the quantities and nature of the Work and materials necessary for completion of the Works and the means of access to the Site by land and sea, to have himself obtained all necessary information as to risks, contingencies and other circumstances which may influence or affect his Tender.

All information in this Functional Specification denoted with an asterisk (\*) shall be supplied by the Tenderer in return with his Tender, which means that a marked copy of this specification including all requested data needs to be submitted.

### 1.4 Coordination and Inspections

In order to ensure that the public health and environmental requirements will be met during the implementation of the project there shall arrangements be made for an 'Engineer' to represent the Employer and to carry out duties that will later be specified in the Contract Documents. The Contractor shall also denominate a responsible representative in his Tender.

The Engineer shall have the right to ask for witness tests on the main components before dispatch to Site. During the period of site installation the Engineer will carry out inspection of the Works to ensure the standards of workmanship meet the Specification and are to his satisfaction. After completion of various parts of the installation the Contractor shall provide a test engineer, labour and materials to demonstrate to the Engineer that the plant meets the agreed target.

The site trials shall be carried out under the control of the Contractor's staff and the supervision of the Engineer. The Contractor shall provide all the necessary labour and instrumentation to conduct the tests.



client:	REMPEC
project:	Port Reception Facility
title:	Functional Specification Oily Waste Treatment



## 2 Description of the Works

The design concept of the works is modular. However, local conditions may have an impact on the design of facilities for a specific site. It is therefore at the Tenderers discretion to inform himself as stated in paragraph 1.3.

### 2.1 Modules

The works comprise three elementary building blocks:

- module A: oily water reception and treatment facilities;
- module B: slop oil dewatering facilities;
- module C: oily sludge dewatering facilities.

Module A may require three typical capacities:

- A-I: Flow capacity 10 m<sup>3</sup>/h with a reception/holding tank of 100 m<sup>3</sup>;
- A-II: Flow capacity 20 m<sup>3</sup>/h with a reception/holding tank of 150 m<sup>3</sup>;
- A-III: Flow capacity 50 m<sup>3</sup>/h with a reception/holding tank of 500 m<sup>3</sup>.

Modules A will be required in any case where a port reception and treatment facility is established, Modules B and C are optional.

A simplified diagram is shown below.

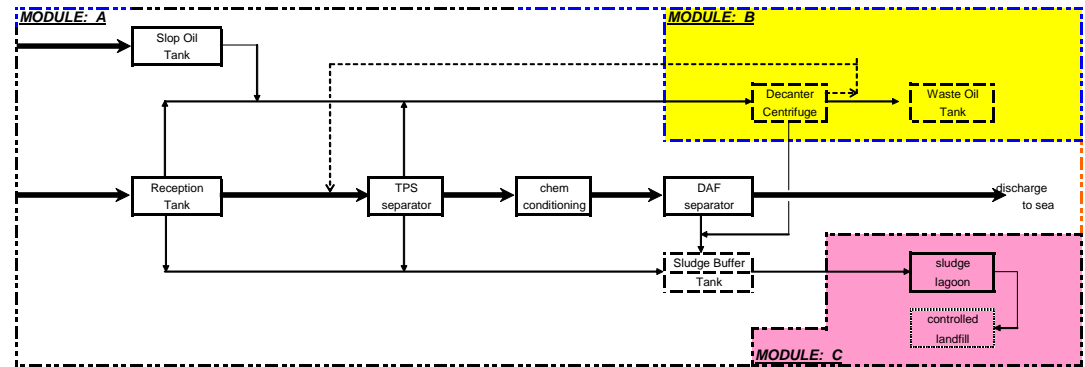

#### Module A: oily water treatment facilities

Oily wastes with high water content (bilge water, tank washings) are transferred to a reception tank, equipped with a skimmer to remove the bulk of free oil. After sufficient residence time, the water fraction shall be withdrawn and pumped to a tilted plate separator (TPS or equal) to remove the remaining free oil.

In some ports an API separator already exists. If that is the case, it may be used to replace the TPS, but this can be recommended only after investigating the equipment to determine whether it is fit for purpose. It is generally assumed that a new TPS will be required.

The second treatment step is coagulation-flocculation followed by flotation (DAF or equal). Metering pumps add the required chemicals to the waste water, air saturated recycle water will be added into a DAF-unit, where all the flocculated oil and solids are separated.

A waste oil holding tank shall be provided for collecting the free oil separated in the holding tank and the TPS. Also slops and other oily residues (with high oil content) are pumped into this tank. Water that settles in this tank shall intermittently be drained and led to the TPS.

A sludge tank shall be provided for holding the sludge's collected in the oil/water separator and the DAF unit. The treated effluent shall contain less than 10 ppm oil and shall be discharged to a sewer or the sea, occasionally the effluent oil content can be subject to stricter applicable local/national requirements (for example, in Greece, the standard is 5 ppm).

**Module B: slop oil treatment facilities**

Module B can be an optional item based on the local circumstances. If the waste oil needs to meet specifications for further use a centrifuge shall be applied. Water which is separated (3-phase decanter) will be re-routed to the TPS; the solids will be transferred to the sludge buffer tank and ultimately stored in a landfill. The oil, free of solids and water is stored in a buffer tank ready for further use.

Again, module B should only be built if the need for it has been firmly established, and this can only be done by the employer, investigating locally how the oil can be disposed of. If eventually it appears that the oil cannot be used by anyone, it may then be required to install a dedicated incinerator for waste. In that case any residual effluent discharged to a sewer or the sea shall contain less than 10 ppm oil. Moreover the effluent oil content can occasionally be subject to stricter applicable local/national requirements (for example, in Greece, the standard is 5 ppm).

**Module C: residual sludge treatment facilities**

Dewatering of sludge, separated in the modules A and B, shall take place in a lagoon from where the sediments shall be sent to a controlled landfill for final disposal. If not stated otherwise, Module C will be built locally.

**2.2 Design Basis**

Ship-related operational oily waste can come from numerous sources. Annex I of MARPOL 73/78 contains certain regulations and interpretations related to procedures for the retention onboard, treatment, discharge at sea and disposal of oily mixtures generated in the machinery spaces of all ships and the cargo areas of oil tankers.

**Oily Waste Characteristics**

Oil is defined as petroleum in any form including crude oil, fuel oil, sludge, oil refuse and refined products other than petrochemicals:

- oily wastes mean oil residues (sludge) and oily bilge-water:
- oil residues (sludge) mean:
  - separated sludge, which means sludge resulting from purification of fuel and lubricating oil;
  - drain and leakage oil, which means oil resulting from drainages and leakages in machinery spaces; and
  - exhausted oils, which means exhausted lubricating oil, hydraulic or other hydrocarbon-based liquid which are not suitable for use due to deterioration and contamination.

	client:	REMPEC				
	project:	Port Reception Facility				
	title:	Functional Specification Oily Waste Treatment				
office: Hengelo	Order: 33202	document: 3181001	rev.: B	sheet: 10	of: 49	

- oily bilge water means an oil – water mixture potentially containing sea and fresh water, fuel oil, cooling water, leakage and lubricating oil, accumulated either in designated holding tank/s or bilge wells:
- oily Mixture means a mixture of aforementioned oil components.

The loading figures are based on the global data presented the study reports of Activities A and C as summarised in paragraph 4.1, Tables 1 and 2.

Oil - water mixtures can have varying characteristics depending on their density and appearance (free/emulsified).

**Free oil**

Oil may be present in water as free oil, forming a surface layer or as small oil droplets dispersed in water by (vigorous) mixing.

**Emulsified oil**

Seawater acts as a natural emulsifier, increasing the viscosity of the oil-water waste, which makes it difficult to pump the oily waste from the barges to shore tanks for processing. Crudes and slops often contain chemical emulsions which have been stabilized by inorganic impurities, viscosity stabilizers, etc. Tank cleaning operations also may results in an oil-water emulsion.

**2.3 Guarantees**

Tenderer shall guarantee that the equipment offered will be free from fault in design, materials and workmanship and will perform satisfactorily in accordance with the service and performance conditions specified.

The Contractor's guarantees given when tendering in respect both of performance and efficiency will be binding and considered part of the Contract.

Contractor shall promptly correct or replace any and all defects found in the mechanical design, materials or workmanship in the purchase order to the full satisfaction of Employer (without any additional costs).

The fulfilment of these guarantees shall be verified at the works test and at Site trials in accordance with the procedure given in the latest editions of ISO 2548 and IEC 60034 etc.

**2.4 Detailed Design**

Before commencing any part of the Works the Contractor shall submit his detailed design for the approval of the Employer. The detailed design shall be unambiguous and facilitate the assessment of the technical execution.

The grading of a treatment plant and the location of the units and service building can be important factors in its successful operation. The grading must provide protection against storms and natural drainage patterns must be used as far as possible.

	client:	REMPEC				
	project:	Port Reception Facility				
	title:	Functional Specification Oily Waste Treatment				
office: Hengelo	Order: 33202	document: 3181001	rev.: B	sheet: 11	of: 49	

Roadways, walkways, and the location of buildings must meet the operational requirements of a site.

Some conceptual information on those items is given in the following Attachments:

- attachment I to III: Process Flow Diagrams;
- attachment IV and V: Principle lay-outs, Plot Plans.

## 2.5 Inspections

The equipment shall be inspected by Employer during construction. Sufficient inspections shall be made to ensure that the materials, construction and testing comply in all respects with the requirements of the local and national authorities and this specification. Any approval given by an Inspection Authority or by the Employer does not absolve the Contractor from his responsibility for compliance with the applicable requirements of this specification.

	client:	REMPEC			
	project:	Port Reception Facility			
	title:	Functional Specification Oily Waste Treatment			
office: Hengelo	Order: 33202	document: 3181001	rev.: B	sheet: 12	of: 49

### 3 Employer's Requirements

The Government of ..... has decided to install at ..... a port reception facility for the needs of the Port Authorities.

In accordance with the MEDA Project, Reports of Activity A, B and C (port reception facilities for collecting ship-generated garbage, bilge waters and oily wastes in the Mediterranean) this Specification provides the functional requirements of modularly designed facilities.

#### 3.1 Module A (reception and treatment facilities)

Module A consists of the following main components:

- reception tank with floating skimming device (T-101/T-201/T-301)<sup>1</sup>;
- slop oil tank (T-103/T-203/T303);
- sludge buffer tank (T-104/T-204/T-304);
- static oil separation (API or enhanced separator);
- dissolved air flotation;
- transfer and recycle pumps;
- sludge draw-off pumps.

Oily waste shall be delivered to the reception tank or to the slop oil tank. The delivery circumstances are locally specific and must be clarified in detail with the Employer.

##### 3.1.1 Reception and holding tanks

Tanks shall be designed as aboveground storage tank with fixed roof for class K3 combustible liquid.

Tank foundation shall be stable and capable of supporting the total weight of the tank and its contents. The tank system's exterior and interior must be protected with an appropriate coating or paint.

Tanks shall generally be equipped with a normal and an emergency ventilation system, fill port, suction device with expansion relief valve and drainage facilities. Design and Performance Standards shall conform API 200 or equivalent. Tanks shall have two manholes, walkway and stairs where appropriate. Railings shall be in accordance with the safety requirements.

Tanks shall be located in a hydrocarbon resistant dike or a concrete bund wall which is capable to contain 110% of the tank volume.

Tanks must have a local filling indication and shall be labelled or marked so that the filling grade and substance stored can be easily identified from outside the containment area.

<sup>1</sup> The TAG numbers refer to the numbers as presented in the attached drawings

 <b>TEBODIN</b> Consultants & Engineers	client:	REMPEC			
	project:	Port Reception Facility			
	title:	Functional Specification Oily Waste Treatment			
office: Hengelo	Order: 33202	document: 3181001	rev.: B	sheet: 13	of: 49

Generally the following incoming oily waste streams shall be sent to the corresponding tanks:

**Reception Tank (T-101/T-201/T-301)**

- ballast water;
- untreated bilge water;
- tank washings.

**Slop oil tank (T-103/T-203/T303)**

- slop oil from ships;
- slop oil from treatment plant.

**Sludge Buffer Tank (T-104/T-204/T304)**

- oily sediments from Static oil separator;
- oily sediments from flotation unit;
- floating matter from flotation unit;
- oily concentrates from decanter centrifuge;
- oily mud from TPS;
- mud from tank cleaning operations.

**3.1.2 Oil removal**

Since the works shall be designed for heavy duty concerning the mineral oil contamination, it is strongly advised to install a two step oil removal treatment. In order to minimise the sludge production the dosage of iron salts and flocculant aid should be as low as reasonably achievable. The Tenderer shall specify and guarantee the average and the maximum chemicals consumption.

It might be essential to conduct a number of trial runs on laboratory scale prior to the ultimate design in order to select the appropriate dosing agents for the flotation treatment.

**Enhanced gravity separation**

The enhanced gravity separators have a certain similarity with API separators but include additional internal features that enhance the separation of oil and water.

A lamella type separator (tilted/corrugated plates) will be preferred.

**Flotation (DAF-unit)**

A lamella separator shall be used to increase the effective separation surface of the plant so that its maximum admissible hydraulic load is higher than that of traditional plants of equal dimensions. Surface scrapers shall remove the scum while the settled solids shall be discharged by pump or by gravity.

The clear water flows behind the submerged scum board into the clear water chamber from where it exits over a height-adjustable weir into the clear water outlet. The water level in the flotation tank and consequently the immersion depth of the scraper bars shall be adjustable by means of this weir.

 <b>TEBODIN</b> Consultants & Engineers	client:	REMPEC			
	project:	Port Reception Facility			
	title:	Functional Specification Oily Waste Treatment			
office: Hengelo	Order: 33202	document: 3181001	rev.: B	sheet: 14	of: 49

A partial flow of clarified water shall be reused as pressure water. The air (over)pressure for dissolving purpose should be 6 bar minimum. The micro bubbles that are produced on release of pressure should preferably have a diameter of 40-70 µm.

Air addition can be achieved by a compressor feeding directly into the rotor casing of the pump.

The required rejection rates and effluent concentrations are presented in section 4.2.2, table 4. These figures must be guaranteed at a chemical consumption to be specified by the Tenderer.

### 3.2 Module B (slop oil dewatering facilities)

For the separation of oil, water and mud a three phase machine might be applicable. However for the reliability of operation a two phase machine might be preferable. In that case the centrate will contain water and mud which can easily be separated in the flotation unit. The Tenderer shall compute the remaining water in the oil phase.

Module B consists of the following main components:

#### Dewatering unit with

- transfer and feed pump;
- decanter centrifuge (2-phase optional 3-phase);
- flocculant aid preparation and dosage system;
- centrate pump pit;
- water and oil discharge pumps;
- waste oil holding tank (prior to re-use).

The centrifuge shall be of the solid bowl (decanter) type. The achievable rejection rates and effluent concentrations shall be filled in in section 4.2.2, table 5. These figures must be guaranteed at a chemical consumption to be specified by the Tenderer.

#### Waste oil holding tank

See section 3.1.1 intake and holding tanks.

### 3.3 Module C (sludge treatment facilities)

Lagoons should be located at least 500 m downwind from the nearest housing area and away from any likely area of future expansion. Otherwise odour release is most likely to become a problem even for a well designed and properly maintained system.

There should be vehicular access to and around the lagoons and, so as to minimise earthworks, the site should be flat or gently sloping.

	client:	REMPEC				
	project:	Port Reception Facility				
	title:	Functional Specification Oily Waste Treatment				
office: Hengelo	Order: 33202	document: 3181001	rev.: B	sheet: 15	of: 49	

Geotechnical aspects of lagoon design are important. The principal objectives of a geotechnical investigation are to ensure correct embankment design and to determine whether the soil is sufficiently permeable to require the lagoon to be lined. The maximum height of the groundwater table should be determined, and the following properties of the soil at the proposed lagoon location must be measured:

- particle size distribution;
- maximum dry density and optimum moisture content (modified Proctor test);
- layer thickness (must exceed 2.0 m);
- Atterberg limits;
- organic content;
- coefficient of permeability.

At least four soil samples should be taken per lagoon, and they should be as undisturbed as possible. The samples should be representative of the soil profile to a depth 1 m greater than the envisaged lagoon depth.

The Tenderer shall be aware that the local circumstances can influence the lagoon dimension. The Tenderer must calculate embankments, lining, inlet and outlet structures. It must be decided, which security equipment (fencing, lifesavers and notices) is generally required, and which operator facilities must be provided.

The construction and operation of the lagoon shall include a high level of environmental protection measures, which have been determined on the basis of the assessment of potential impacts and mitigation measures. Environmental protection shall be a key factor in the design and operation of the site.

The environmental protection measures are inherent in the design and operations. An important aspect of the work will be to ensure that the high standards are passed to any future operator. This will include setting up an accessible training programme.

In addition to following good practice, this high level of regard for the environment will also minimise future liability for damages or clean-up costs. This will be especially important if a commercial operator and its subsequent customers are to be attracted to the site.

A Health and Safety Plan shall be finalised in cooperation with the Contractor and shall contain the details of the emergency response plan. A limited number of potential emergency situations are envisaged for project operations. These are:

- spillage of waste outside the lagoon;
- fire in the offices or on board vehicles;
- accidents involving moving vehicles.

These emergencies must be anticipated and, as much as possible, prevented by operational procedures.

	client:	REMPEC			
	project:	Port Reception Facility			
	title:	Functional Specification Oily Waste Treatment			
office: Hengelo	Order: 33202	document: 3181001	rev.: B	sheet: 16	of: 49



## 4 Technical Requirements

### 4.1 Modules for Tendering

Summarizing the results of the recommendations made in the Activity B report (MED.B7.410097.0415.8) technical plants as specified in the tables 1 and 2 are required.

The required delivery items are separated in procedures for international or national Tendering. Exclusions from delivery are specified and indicated in terms of complete modules.

According to the Activity B report, the following ports shall be equipped with oily water treatment facilities:

**Table 1: Module Requirements (MED.B7.410097.0415.8 - Activity B)**

Country	Port	Module			Remarks
		International Tender		National Tender	
		Delivery	Exclusion	Delivery	
Algeria	Algiers	A-I	B-I, C-I	none	
	Arzew & Bethioua	A-I	B-I, C-I	none	
	Skikda	A-III	B-III, C-III	none	
Egypt	Alexandria	A-I	B-I, C-I	none	
	Dhekelia <sup>2</sup>	A-II	B-II, C-II	none	
	Port Said	A-I	B-I, C-I	C-I	
Israel	Hadera	none	none	Reception Tank Volume 50 m <sup>3</sup>	Component of A-I
Lebanon	Beirut	A-I	C-I	C-I	Final oil disposal to be clarified
	Tripoli	A-I	C-I	C-I	
Morocco	Nador <sup>2</sup>	A-II	C-II	C-II	
Syria	Banias	1Mod.A 300 m <sup>3</sup> /h	B-III, C-III	none	Special designed Common Plant
	Tartous Oil Terminal				
	Tartous	A-I	B-I, C-I	C-I	
Tunisia	La Goulette	A-I	B-I, C-I	C-I	
	Sfax	A-I	B-I, C-I	C-I	

<sup>2</sup> Although module A-I might be appropriate, module A-II seems to be more convenient for this port.

Country	Port	Module			Remarks
		International Tender		National Tender	
		Delivery	Exclusion	Delivery	
Turkey	Antalya	A-I	B-I, C-I	C-I	Final oil disposal to be clarified
	Bordum	A-I	B-I, C-I	None	Final oil disposal to be clarified
	Izmir	A-I (mod)	B-I, C-I	none	No Reception Tank No Slop Oil Tank
	Nemrut Bay	A-I	B-I, C-I	C-I	
Cyprus	none	none		none	
Malta	none	none		none	

## 4.2 Design Objectives

The Design of the Port Reception Facility Modules is based on the physical and chemical properties of waste oil which can have varying properties with specific gravities between 0.85 up to 1.15 [kg/dm<sup>3</sup>]. Crudes may contain alkanes, alkenes, aromatic compounds or asphaltic compounds. Refined products have an even greater range of properties, because many have molecular structures not even found in nature. Both natural and refined products may also contain sulphur or nitrogen compounds that change their characteristics. Small concentrations of metals may also be present.

Table 2 summarizes the main characteristics of waste oil that shall be expected at delivery to the Reception Facilities.

**Table 2: Typical composition of oily wastes**

	Composition				Type of oil to be treated
	Oil		Water	Solids	
	[ppm]	[%]	[%]	[%]	
Dirty ballast	100	0.01	Approx. 100	Traces	Free (mainly crude)
Bilge water untreated	20,000	2	98	Traces	Free and emulsified oil (mixtures)
Tank washings	30,000	3	97	Traces	Free and emulsified oil (mixtures)
Slops/oily residues	300,000	30	65	5	Free and emulsified oil (mixtures)

#### 4.2.1 Module Specification

Table 3 presents the specification of the main components required for the Modules as aforescribed.

**Table 3: Main Component Specification per Module**

Module	Item	Volume/Flow	Module	Item	Volume/Flow	Module	Item	Volume/Flow
A I	Reception Tank	100 m <sup>3</sup>	B I	Decanter	1...5 m <sup>3</sup> /h	C I	Lagoon	500 m <sup>3</sup>
A I	CPS	10 m <sup>3</sup> /h	B I	Waste Oil Tank	50 m <sup>3</sup>		Floating Pump	5 m <sup>3</sup> /h
A I	DAF	10 m <sup>3</sup> /h		Waste Oil Pump	10 m <sup>3</sup> /h			
A I	Sludge Buffer Tk	50 m <sup>3</sup>						
A I	Slop Oil Tank	50 m <sup>3</sup>						
A II	Reception Tank	150 m <sup>3</sup>	B II	Decanter	1...5 m <sup>3</sup> /h	C II	Lagoon	1000 m <sup>3</sup>
A II	CPS	20 m <sup>3</sup> /h	B II	Waste Oil Tank	50 m <sup>3</sup>		Floating Pump	5 m <sup>3</sup> /h
A II	DAF	21 m <sup>3</sup> /h		Waste Oil Pump	15 m <sup>3</sup> /h			
A II	Sludge Buffer Tk	100 m <sup>3</sup>						
A II	Slop Oil Tank	100 m <sup>3</sup>						
A III	Reception Tank	500 m <sup>3</sup>	B III	Decanter	5...10 m <sup>3</sup> /h	C III	Lagoon	4000 m <sup>3</sup>
A III	CPS	50 m <sup>3</sup> /h	B III	Waste Oil Tank	200 m <sup>3</sup>		Floating Pump	10 m <sup>3</sup> /h
A III	DAF	55 m <sup>3</sup> /h		Waste Oil Pump	25 m <sup>3</sup> /h			
A III	Sludge Buffer Tk	200 m <sup>3</sup>						
A III	Slop Oil Tank	100 m <sup>3</sup>						

#### 4.2.2 Removal efficiencies

The influent oil content of the oily water intake as presented in table 2 is very conservatively estimated. The required degradation efficiencies shown in table 4 and 5 are regarded to be achievable with the selected treatment technologies.

**Table 4: Percentage of degradation required**

Pollutant	Average Effluent [mg/l]	Required Degradation			Matter
		API/CPS	DAF	Over-all	
Suspended Solids	20.0	80%	90%	98.0%	SS
Floating Particles	0.0	50%	99.9%	99.7%	Float
pH <sup>1)</sup>	6...9	(*)	(*)	(*)	pH
Oil&Grease	< 10.0	85%	>99.5%	>99.5%	Oil/Grease
Hydrocarbons (IR)	0.1	20%	90%	92.0%	HC

- <sup>1)</sup> Tenderer is requested to consider the need of pH correction with his system prior to effluent discharge. Tenderer shall guarantee the degradation rates and/or effluent concentrations. These figures will become subject of the Contract Documents.

**Table 5: Effluent quality of slop oil after dewatering**

Pollutant	Max. Influent [mg/l]	Achievable Degradation <sup>2)</sup>		Circa Effluent [mg/l]
		2-phase decanter	3-phase decanter	
Suspended Solids	50,000	(*)	(*)	(*)
Oil	300,000	(*)	(*)	(*)
Water	650,000	(*)	(*)	(*)

2) Tenderer shall guarantee the achievable rejection rates and effluent concentrations at chemical Consumptions (to be specified by Tenderer). These figures will become subject of the Contract Documents.

### 4.3 Lagoon design

The lagoon required for Module C shall be designed and constructed for the disposal of oil contaminated sludge arising from the Port reception Facilities in ..... Oily sludge of different kind shall be collected in the Sludge Buffer Tank from where it will be transferred to the lagoon for further dewatering.

In the lagoon the water content of the sludge will be reduced by evaporation, dried sludge will pile up and must be removed as hazardous waste to the local landfill.

It must be emphasized that the ultimate dimensions of the lagoon might be influenced by local circumstances. An indication of the required lagoon capacity can be obtained from table 3.

As shown in Figure 1, the Tenderer shall base his calculation of the ultimate lagoon dimensions on a mid-depth area. The top and the bottom dimensions shall be calculated as demonstrated in figure 1. These mid-depth dimensions need to be corrected for the slope of the embankment.

**Figure 1: Principal lagoon dimensions**

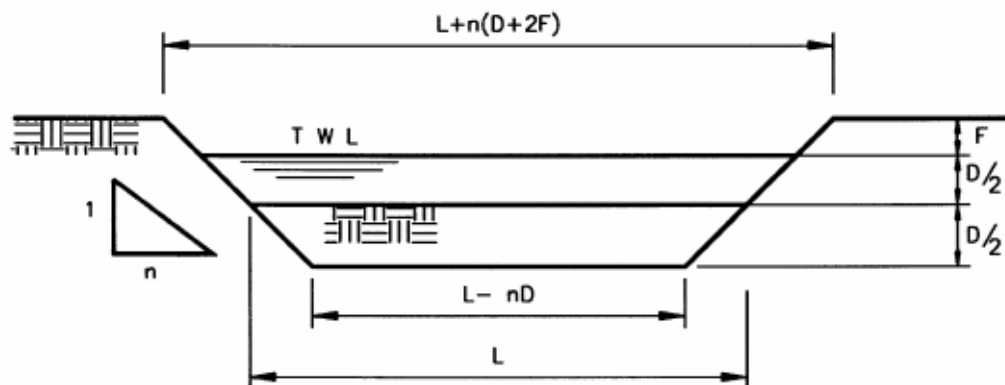

The minimum freeboard (F) that should be provided shall be decided on the basis of preventing waves, induced by the wind, from overtopping the embankment. For small lagoons a minimum of 0.5 m freeboard should be provided.

The depth (D) chosen for any particular lagoon depends on site considerations (presence of shallow rock, minimisation of earthworks). The depth should exceed 1.5 m so that dried sludge resulting from water evaporation can be deposited for approximately one year.

Ideally, embankments should be constructed from the soil excavated from the Site, and there should be a balance between cut and fill, although it is worth noting that lagoons constructed completely in cut may be a cheaper alternative, especially if embankment construction costs are high.

The soil used for embankment construction should be compacted in 150-250 mm layers to 90% of the maximum dry density as determined by the modified Proctor test. Shrinkage of the soil occurs during compaction (10-30 percent) and excavation estimates must take this into account. After compaction, the soil should have a coefficient of permeability, as determined in situ, of  $<10^{-7}$  m/s.

Wherever possible, embankment design should allow for vehicle access to facilitate maintenance. Embankment slopes are commonly 1 to 3 internally and 1 to 1.5-2 externally. Steeper slopes may be used if the soil is suitable; slope stability should be ascertained according to standard soil mechanics procedures for small earth dams. Embankments should be planted with grass to increase stability: a slow-growing rhizomatous species should be used to minimize maintenance.

External embankments should be protected from storm water erosion by providing adequate drainage. Internal embankments require protection against erosion by wave action, and this is best achieved by in situ concrete or stone rip-rap at top water level. Such protection also prevents vegetation from growing.

**Prevention of soil contamination**

To protect the environment against the possible migration of hazardous substances the pathways and geological barriers must be identified.

As a general guide for the sub-soil permeability, the following interpretations may be placed on values obtained for the in situ permeability coefficient:

- $k > 10^{-6}$  m/s: the soil is too permeable and the lagoons must be lined;
- $k > 10^{-7}$  m/s: some seepage may occur, it is advisory to use a geotextile liner;
- $k < 10^{-8}$  m/s: the sub-soil will seal naturally; but still use a geotextile liner for safety reasons;
- $k < 10^{-9}$  m/s: there is no risk of groundwater contamination, if the groundwater is used for potable supplies use a geotextile liner for safety reasons;
- $k > 10^{-9}$  m/s and the groundwater is used for potable supplies, a geotextile liner is not essential.

	client:	REMPEC			
	project:	Port Reception Facility			
	title:	Functional Specification Oily Waste Treatment			
office: Hengelo	Order: 33202	document: 3181001	rev.: B	sheet: 21	of: 49

In order to prevent soil contamination or to affect the groundwater quality the lagoon shall be lined. The liner construction shall comprise the haulage and placement of selected materials suitable for liner construction. The liner materials will be spread in thin lifts and thoroughly compacted.

The Contractor will be required to control the moisture content and compaction of the fill to ensure that the required fill density is achieved, A QA plan shall be provided to confirm that the required moisture content, density and permeability are achieved on each lift of the clay liner.

Particular care must be taken to ensure that the sump is properly lined with clay and that the surface of the clay liner throughout the lagoon excavation is suitable to receive a geomembrane liner. The Contractor will be required to spray the surface of the clay liner periodically with clean water to prevent the formation of desiccation cracks.

A variety of lining materials is available and local costs dictate which should be used. Satisfactory lining can be achieved with ordinary Portland cement (8 kg/m<sup>2</sup>) or with plastic membranes on 150- 300 mm layers of low-permeability soil.

If plastic membranes are used the preference will be given to a HDPE geotextile liner. The installation of this liner shall be carried out by a specialist Sub-Contractor experienced in the supply, deployment and seaming of HDPE geomembrane liners.

If plastic membranes are used the Contractor will be required to use plant and operating procedures that ensure that the protection layers are placed to the required thickness without causing damage to or displacement of the underlying liner materials. The Contractor will not be permitted to operate plant within 1.0 m of the geomembrane liner.

The geotextile protection layer shall be anchored with sandbags. If this work is carried out during the summer months it is probable that night working will be required as daytime temperatures may be too high. The QA programme will address conformance testing of the geomembrane and geotextile materials.

All seams shall be tested to confirm continuity and a programme of destructive tests will be established to ensure that seam strength criteria are achieved.

On completion of the HDPE layer a sand protection layer shall be placed to the required thickness (min. 0.75 m) taking care not to damage the liner system. Leak location surveys shall be carried out to ensure the integrity of the geomembrane liner prior to the start of filling the lagoon.



client:	REMPEC				
project:	Port Reception Facility				
title:	Functional Specification Oily Waste Treatment				
office: Hengelo	Order: 33202	document: 3181001	rev.: B	sheet: 22	of: 49

Figure 2 shows a typical excavation for a lagoon at a selected site.



**Figure 2: Lagoon excavation**

Two typical inner embankment constructions are shown in Figure 3 and Figure 4.

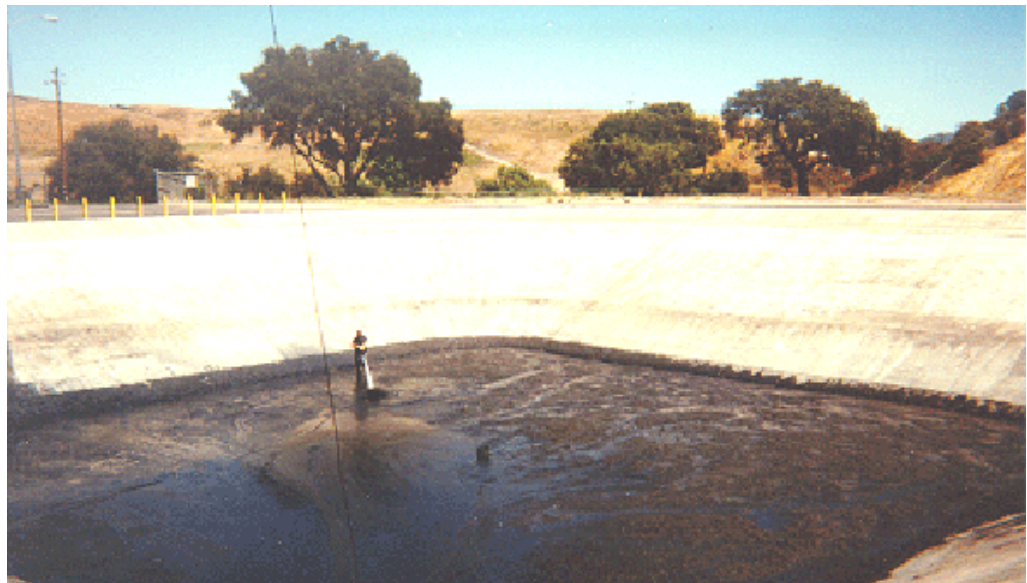

**Figure 3: Lagoon with proper concrete inner embankment protection**



Figure 4: Lagoon with sand embankment on HDPE geotextile liner



## 5 General Specifications

### 5.1 Responsibility

The Tenderer is responsible for the completeness and accuracy of his design calculations and for compliance with all applicable requirements of this specification.

The Contractor shall be obliged to prepare and submit a Hazard Analysis and Risk Assessment (HARA) for his plant.

If during the Tender preparation unexpected factors may arise which in the judgment of the contractor justify deviations from the specified requirements but which do not affect the guarantees as requested for by this specification, the Tenderer may propose adequate variations and be bound by the same conditions, so far as applicable, as though the said variations were stated in this Specification. The Contractor shall not alter any of the Works except as directed in writing by the Employer.

The Contractor shall in the manufacture of the Plant and in the execution of work on Site observe and comply with and be bound by the laws of the country of manufacture concerning the manufacture of the Plant and the laws of the country where the Plant is to be erected and work to be executed so far as such laws concern the manufacture erection and operation of the Works.

### 5.2 Standards and Regulations

As a minimum shall goods, materials and workmanship comply with the latest issue of the National or International Standards or Code of Practice as referred to in this Specification, or comply with alternative equivalent internationally recognised Standards.

Full details in English/French/national language of alternative equivalent internationally recognised standards for works proposed shall be provided with the Tender.

All materials, construction, inspection, testing and all aspects of design shall be in compliance with:

- a) Codes and Standards as afore defined;
- b) Current Good Engineering Practices;
- c) European Directives (if applicable).

All the possible measures and precautions shall be taken to account during lay-out and installation that operation, maintenance and service can take place without hazards to the personnel.

The equipment shall also be designed to prevent the physical exhaustion of the working personnel in order to minimise the risk of occupational hazards.



client:	REMPEC
project:	Port Reception Facility
title:	Functional Specification Oily Waste Treatment

More specifically shall the following standards, codes and guidelines be adhered to (as far as reasonably practical):

- European directives such as Machinery Directive, Low Voltage Directive, Electro Magnetic Compatibility Directive, Pressure Equipment Directive (PED), ATEX directive etc.;
- EHEDG design guidelines, especially guidelines 8, 9, 14, 16 and 18 for piping;
- CE marking.

### 5.3 General Requirements

Battery limits are basically defined at:

- delivery nozzles;
- fused feed cable;
- earthing cables;
- terminal box for common alarm and reset.

Tenderer is requested to define the battery limits in detail in his proposal.

All equipment shall be tagged at an accessible point with a nameplate with engraved the following data:

- supplier;
- purchase order number;
- type Year of manufacturing;
- main engineering data.

Vessels and other items which are subject to authority approval need additionally be tagged in accordance with the authority regulations.

### 5.4 Documentation

All documentation shall be furnished in the National language, English or French.

Shop drawings and calculations shall be submitted to Employer for approval before starting fabrication. Each shop drawing shall be fully checked and signed as checked by the Contractor or his representative before it can be accepted for approval. Shop drawings shall have the nozzle numbered and lettered, corresponding to the individual vessel drawing or data sheets. The approval of drawings, calculations and welding procedures by Employer does not release the Contractor of his responsibility.

#### 5.4.1 Manufacturing report

The Contractor shall issue a certificate that the equipment has been designed, fabricated and tested in accordance with this specification and the requirements of the local and national rules and regulations. This inspection and test report shall be countersigned by the Inspecting Authority that it has been so constructed and tested accordingly. The countersigned certificate shall be furnished to Employer.



client:	REMPEC
project:	Port Reception Facility
title:	Functional Specification Oily Waste Treatment

The manufacturing report shall include:

1. index;
2. copy of the purchase order;
3. copy of all shop drawings with equipment lists;
4. copy of the calculations;
5. copy of authority approval letter and other important correspondence;
6. approved welding procedure specification;
7. material certificates with a reference to the drawing and part number;
8. sketch showing the location of radiographs and film numbers;
9. results of non-destructive examination and destructive testing;
10. inspection and test report;
11. photograph of the nameplate and/or number plate.

#### **5.4.2 Documents for regulatory approvals by relevant authorities**

The Contractor shall provide drawings needed to apply official permits, certificates, regulatory approvals and licences from relevant authorities. The Employer shall assist in the preparation of such documents.

#### **5.4.3 As-built drawings**

As-built drawings shall be prepared of each part of the Works. These drawings shall include but not be limited to the following:

- (a) site map showing the Location of the part of Works on the plot;
- (b) elevations;
- (c) plans and sections;
- (d) details of installations;
- (e) any other drawing as may be agreed between the Employer's Representative and the Contractor.

The scales of the as-built drawings are recommended in section 5.4.7 but shall be specified in the Contract Documents.

#### **5.4.4 Manuals**

For each item/equipment supplied by the Contractor, manuals shall be prepared for installation, operation and maintenance instructions. These manuals shall include all installation details and particulars, list of parts and related explosion drawings, catalogues, test certificates and test records, operating instructions and any other information or instructions which may be needed or required or useful in the installation, operation, maintenance, repair, dismantling or assembling of the equipment and for repair and identification of parts for ordering replacements. The manuals shall be collected under a suitable common cover as listed below. If the Contractor's standard bulletins are supplied, they shall be clearly marked to indicate the specifications applicable to the particular equipment which is supplied. Prints of drawings reduced to suitable size shall be included in each instruction book.



client:	REMPEC
project:	Port Reception Facility
title:	Functional Specification Oily Waste Treatment

**Installation Manuals**

The Installation Manuals, which shall be issued in A 4 size format, shall simply and clearly define all the installation details, physical dimensions of the Plant and, if necessary, all safety requirements during the installation. The booklets shall have separate sections setting out instructions on a 'do' or 'do not' format.

**Operation Manuals**

The Operation Reference Manuals, which shall be issued in A 4 size format, shall simply and clearly define all the aspects necessary to enable the user or operator to safely and efficiently operate the plant equipment. The booklets shall have separate sections setting out instructions on a 'do' or 'do not' format.

The Operation Manuals shall be formulated and sectioned appropriately for the Training Programme the Contractor will be utilising when training the Employer's operational staff.

**Maintenance manuals**

The Maintenance Reference manuals shall be in A 4 size, in loose leaf folder format. The equipment shall be in alphabetic order. Each individual manual shall have main sections for each of the disciplines according to the principle given by the Employer's Representative.

Each main section shall have subsections as follows:

1. general data of each machine or item;
2. condition monitoring and fault diagnosis (trouble shooting guide);
3. schedule of planned maintenance routines (daily, weekly, monthly, annual etc.);
4. detailed description of operation;
5. service procedure;
6. method of component removal (explosion diagrams);
7. repairs including use of special tools;
8. test procedure following maintenance and repairs;
9. schedule of special tool required;
10. lubrication (lubricant, quantity, sequence of change).

Cross reference shall be made to relevant drawings where applicable in the maintenance manual text. Extensive use shall be made of photographs wherever possible to illustrate maintenance procedures.

**5.4.5 Submittal, review and approval of documents**

The copies (number stated in appropriate clauses) of each drawing shall be submitted to the Employer's Representative to which a log (control) number has been assigned.

If any revision is made to a drawing after it has been approved, the Contractor shall re-submit appropriate number of prints to the Employer's Representative for further approval. The Employer's Representative shall have the right to request for any additional details and to ask the Contractors to make any change in the drawings which are necessary to conform to the provisions and intent of the Employer's Requirements without additional cost.

	client:	REMPEC				
	project:	Port Reception Facility				
	title:	Functional Specification Oily Waste Treatment				
office: Hengelo	Order: 33202	document: 3181001	rev.: B	sheet: 28	of: 49	

#### 5.4.6 Other instructions for documents

The drawings and calculations which have to be produced by the Contractor shall be made and submitted in accordance with the following regulations:

A choice of recommendable metric scales are 1:500, 1:100, 1:50, 1:20, 1:10, 1:5, 1:2 or 1:1, depending on the kind of drawing and/or details which have to be drawn.

All costs, related to the supply to the Employer's Representative of the mentioned number of drawings and calculations, shall be included in the Contract Price.

### 5.5 Quality Requirements, Testing

#### Shop tests

Tenderer shall perform in his shop all the required tests. Tenderer shall include in his quotation full details of the intended test program including measurement procedure.

It shall be the Contractor's responsibility to liaise with and co-ordinate the activities of his sub-contractors associated with any part of the Works and to ensure that all parties concerned are present during any tests to obligate their responsibilities within the defined limits to their individual contracts.

Test certificates shall be provided giving detailed records of all electrical and mechanical tests carried out on the equipment and material including lifting equipment, tanks, pressure vessels, and cables and cabling both in the manufacturer's works and at Site.

#### Site tests

Leakage tests at the test pressure shall be carried out on all erected pipe work and valves immediately after erection and before being built in. The Contractor shall advise the Engineer when these tests are to be carried out.

The site trials shall be carried out under the control of the Contractor's staff and the supervision of the Engineer. The Contractor shall provide all the necessary labour and instrumentation to conduct the tests.

The site reliability trials shall be carried out in accordance with ISO 1204 under the control of the Contractor's staff and supervision of the Engineer. The purpose of the site tests will be to confirm the works tests and to determine the fuel consumption for the purpose of comparison with the Guarantees entered in the Contract.

### 5.6 Commissioning and Take Over

The objective of all commissioning activities is to verify that equipment, system(s) and/or facilities meet the design and engineering specifications and to obtain documentary evidence of this.

These objectives are mainly achieved by carrying out inspections, checks and tests and reporting the findings throughout the project.



client:	REMPEC
project:	Port Reception Facility
title:	Functional Specification Oily Waste Treatment

The commissioning activities start as soon as the construction drawings are issued. These preparatory activities mainly take place at the office and the first pre-commissioning activities at the site will be carried out when the majority of the equipment has been installed. The remaining commissioning activities follow and will end when the plant has been formally accepted by or on behalf of the Employer including any adjustments or variations to the Tender agreed between the Employer and the Contractor.

## 5.7 Training for operation and maintenance

### 5.7.1 General

The Contractor shall provide training to personnel assigned by the Employer's Representative. Training shall commence during the construction period and continue throughout the Commissioning period.

### 5.7.2 Training Programme

The Contractor shall provide a fully detailed training programme, based on the training programme submitted with his Tender, within two (2) months of the commencement of the Contract.

The training programme shall include, but need not be limited to, the following:

- 1) the organisational structure of the personnel required for management, operation and maintenance of the Works;
- 2) the manpower requirements, by skills and trades, necessary for the management, operation and maintenance;
- 3) reference materials and documents to be provided in the training programme.

### 5.7.3 Contractor's Training Personnel

The Contractor shall provide supervisory personnel for each of the positions required for operation and maintenance of the Works as identified in the training programme. The duties of each of the training personnel, hereinafter referred as Contractor's Counterpart Staff, shall be to supervise and train the staff members to operate and maintain that element or those elements of the Works appropriate to his position. The emphasis shall be on 'hands-on' training.

The Employer's Representative shall provide sufficient workforce for the operation and maintenance of the Works under the supervision of the Contractor's Counterpart Staff. It is envisaged that no less than 2 persons of such Contractor's Counterpart Staff will be at the Works.

In addition to the counterpart staff, the Contractor shall also provide specialist trainers who shall be responsible for formal classroom or workshop training.

	client:	REMPEC			
	project:	Port Reception Facility			
	title:	Functional Specification Oily Waste Treatment			
office: Hengelo	Order: 33202	document: 3181001	rev.: B	sheet: 30	of: 49

**5.7.4 Facilities and Location for Training**

The Contractor shall provide all necessary facilities for training. The training shall take place in premises of .....

**5.7.5 Safety Training**

The Contractor shall pay particular attention to safety training for all assigned personnel. Safety training shall not be limited to personal safety but shall also include detailed actions to be taken by all staff in emergency situations and the use of all safety equipment.

**5.7.6 Language for Training**

Training shall be carried out in the National language, English or French.

## 6 Specification for Mechanical Works

### 6.1 General Requirements

Machinery for outdoor applications shall be equipped with weather protection:

- electrical motors shall be equipped with easily detachable weather shields;
- geared drives of scrapers shall be equipped with easily detachable shield cabinets furnished with cooling air grilles and hinged hatch with snap locks to facilitate the maintenance;
- all the measuring equipment shall be positioned to heated, insulated and splash proof cabinets.

### 6.2 Tanks

Welded vertical tanks can be satisfactorily erected in several ways; no single particular system of erection procedure is specified for use.

Erection contractors normally have their own specific individual method which they have adopted as the result of experience, and have developed the erection technique most suitable for economical working and good workmanship by their field crews.

Provided that the erection contractor employs a method which is known to give good results and that the recommended sequences of erection and welding are followed, the method may be deemed satisfactory. Tenderers shall outline their method of erection before a contract is placed.

During erection, tanks shall be safeguarded adequately against distortion or damage due to wind pressure by the provision of suitable steel wire guys, temporary girders or braces.

Holes in plate work in order to assist in erection are not permitted. Lugs, nuts, clamps, and other devices to assist in erection may be attached to the tank plates by welding, but all such attachments required only for the purposes of erection shall ultimately be removed and any noticeable projections of weld metal remaining shall be carefully ground or chipped away.

The foundation shall remain level as the tank shell is erected. For this reason the foundation shall be checked, not only at the commencement of erection but also several times during the various stages of tank erection. The measurements shall be stated in the manufacturing report.

On site erected tank shells of fixed roof tanks shall be hydrostatically tested after completion of the roof. Testing shall be done by filling the tank with fresh water to the level of the top leg of the top curb angle, and noting any leaks over a period of at least 24 hours.

After the tank shell has been tested with water, the roof shall be tested by pumping air under the roof plates while the tank is still full of water. The influence of sudden barometric changes and possible condensation during the night shall be considered. Non-pressure tank roofs shall be tested to a pressure of 7.5 mbar. For the detection of leaks, soap suds or similar substance shall be applied to all joints.



client:	REMPEC
project:	Port Reception Facility
title:	Functional Specification Oily Waste Treatment



### 6.3 Pumps

The pump duty shall conform the specified Module type in connection with the capacities indicated on the corresponding process flow diagram.

Tenderer shall as a minimum specify the following criteria for each pump:

- Number of pumps installed (\*)
- Total capacity: (\*) m<sup>3</sup>/h
- Estimated differential head: (\*) bar
- Casing Material: (\*)
- Impeller Material (\*)
- Installed power: \* (\*) kW

Pumps shall be generally equipped according to the following list with:

- Feed valve.
- Sluice valve.
- Check valve (if applicable).
- Air removal valve DN 25 of stainless steel with breather pipe DN 25 to sump.
- Drain pipe for stuffing box bleed;
- Pressure gauge in pressure pipe between pump and shut-off valve.
- For the pumps equipped with vacuum evacuation system the stuffing boxes shall be equipped with pressurized water lubrication to minimize leakages when vacuum is applied.
- For sludge and sewage pump stuffing boxes the grease lubrication is preferred (all submersible pumps shall be delivered with oil lubrication). The water lubrication may be applied only in cases of very abrasive medium.
- If not otherwise requested all the pumps shall be equipped with dry running protection.

### 6.4 Pipes

Pipe work shall conform classification DIN 11850 (piping) and DIN 11851 for accessories (flanges etc.). For pressures above 1 MPa, the flanges shall be dimensioned according to DIN 2505.

Pipe work exposed to the occurrence of vacuum or destined for a pressure exceeding 0.6 MPa shall be calculated individually according to the instructions for standards of the pressure vessels.

Elbows for dimensions greater than DN 300 may be manufactured of pipe segments. For pipe diameters DN 300 and smaller pressed elbows shall be used.

Tees shall always be factory made or produced with collaring draw method. Extra welding joints shall be avoided by selecting and adjusting the tees to fit in pipe work lengths. Small branches D:d = 4:1 and smaller may, however be manufactured on site without collar.

The joints in the pipe work shall be made by welding or with weldable collars and flanges, avoiding threaded joints. The threaded joints shall in any case be limited to sizes DN 50 and under.



client:	REMPEC
project:	Port Reception Facility
title:	Functional Specification Oily Waste Treatment

The flanges and collars shall be as follows:

**Collars**

- pressed collars may be used in pipe work dimensions below DN 200 with pressures up to 1 MPa and/or dimensions below DN 400 with pressures up to 400 kPa;
- collars formed of angle iron shall be used with pipe work from dimension DN 200 or greater with pressures above 400 kPa; and
- smitten and formed collars or welding rings shall be used exclusively in pipe work with dimensions of DN 200 or greater and pressures above 400 kPa.

**Flanges**

- aluminium flanges may be used in pipe work dimensions below DN 250 with operation pressures under 1 MPa;
- galvanised steel flanges shall be used exclusively for dimensions DN 300 and greater;
- the flanged joints underground shall be equipped with galvanised steel flanges with 400 µm epoxy tar coating on top of Sa 2 1/2 sand blasted basis and associated primer basecoat.

**Nozzles**

The Tenderer shall submit allowable nozzle loadings (horizontal and vertical forces and moments) for all nozzles.

**Supports**

The supports of the pipes shall be installed into the tanks or alike to submerged stresses shall be constructed of stainless steel. The supports in dry rooms and gangways shall be manufactured of mild steel and painted.

The supports shall allow the stripping down of valves and appliances without dismantling the supports.

The ISO -standards shall be observed on applicable parts:

- Pipe clamps and their billets;
- Hanging supports;
- Sliding supports;
- For stainless steel pipes the possible reinforcement of pipe surrounded by fixed support and axial fixing plates shall be calculated case by case.

**6.5 Valves**

For the installation of valves following aspects shall be observed:

- accessibility for maintenance;
- space requirement for actuator maintenance;
- position of spindle, requirements of medium and operation;
- space required for removal of shaft of check valve;
- design of needed lifting points and assembly hatches.

	client:	REMPEC			
	project:	Port Reception Facility			
	title:	Functional Specification Oily Waste Treatment			
office: Hengelo	Order: 33202	document: 3181001	rev.: B	sheet: 34	of: 49

The manual actuators shall be selected so that the required operation force in sustained service shall not exceed 200 N and temporarily 500 N.

**Sluice gate valve with resilient wedge gate**

- the body of cast iron, lifting spindle;
- gate shall be housed and sealed so that the solid substances are prevented from penetrating to sluice housing;
- flanges and drilling according to PN 10 (DIN 2501);
- internally the valve shall be plastic coated, coating at least 70 µm;
- rated pressure PN 10.

**Butterfly valve of sealing construction**

- body and flap of cast iron or material of similar rigidity and corrosion resistance;
- rated pressure PN 10 up to DN 500;
- flanges and drilling according to PN 10 (DIN 2501) or in waffle models installation between PN 10 flanges.

If not requested otherwise, the electric motor actuators shall be equipped with following features:

- device for manual operation;
- limit indicators suitable for remote control;
- momentum switches for over load and limit stops;
- adjustable control device to park the valve in intermediate positions.

If the actuator is for outdoors application this shall be suitably equipped for purpose.

For drainage application threaded globe type valves shall be used.

**6.6 Corrosion Protection, Painting**

The oily waste from ships may contain seawater to a certain extent. Seawater is a highly corrosive liquid. Therefore the susceptibility to corrosion shall be minimized through the use of corrosion resistant materials or the application of protective internal coatings. Care shall be taken to prevent galvanic corrosion.

The choice of material should be based on life cycle economics, taking into consideration the type of service (water temperature, level of chlorination), the cost of material (noting that higher allowable water velocities imply smaller line sizes), the physical location and the extent of pipe work within the installation. Typical materials which may be considered for an extremely rugged construction include super duplex, high molybdenum stainless steels and glass fibre reinforced thermosetting plastic (GRP).

The following qualities stainless steel are not seawater resistant without further protection:

- AISI 304 corresponding with EN 10088-1...2, DIN 17006 WS No. 4301;
- AISI 316 corresponding with EN 10088-1...2, DIN 17006 WS No. 4436.

	client:	REMPEC			
	project:	Port Reception Facility			
	title:	Functional Specification Oily Waste Treatment			
office: Hengelo	Order: 33202	document: 3181001	rev.: B	sheet: 35	of: 49

The following types of gaskets should be used in seawater systems (in order of preference):

- mineral filled gaskets;
- GRE laminated gaskets;
- spiral wound gaskets with graphite filler with an inner ring more cathodic than the adjacent piping.

Plain graphite gaskets shall not be used with corrosion resistant alloys.

The following protection is proposed:

#### **Steel and Cast Iron Surfaces in Submerged Areas**

Epoxy bitumen combination: four (4) layers of epoxy paint; one primer, three (3) epoxy bitumen paint. Thickness of final coating 400 µm. Primer applied on the sand blasted dry steel surface, cleaning according to standard SA 2 1/2. The surfaces in contact with concrete shall also be painted.

#### **Steel and Cast Iron Surfaces in Climatic Stresses**

Epoxy paint combination: three (3) layers of epoxy paint; one primer, two (2) suitable final epoxy coatings. Thickness of final coating 180 µm. Primer applied on the sand blasted dry steel surface, cleaning according to standard SA 2 1/2.

If the chalking of the epoxy paint is ungainly or harmful, respective polyurethane paint combination shall be used.

#### **Surfaces with Hot Dip Galvanising**

The surfaces in Climatic Stresses epoxy with epoxy paint combination: two (2) layers of epoxy paint; one primer, one suitable final epoxy coating. The metal surface must be chemically cleaned of dirt and grease. Thickness of final coating shall be 100 µm.

The hot dip galvanising shall conform to the instructions of ISO 1459 and ISO 1461 standards. In not requested otherwise in Detailed Specifications, the average zinc quantity on 5 mm and thicker steel structure shall conform to the specification ZnK 500 (respective zinc layer 70 µm) and under 5 mm tick structures ZnK 420 (respective zinc layer 60 µm).

The requirements presented in the ISO-standards shall be observed when designing and manufacturing structures.

The corrosion protective painting of machines and equipment shall at least conform the ISO 2064 (Metallic and Other Non-organic Coatings) standards and specifications.

### **6.7 Noise requirements**

For all systems and equipment overall sound power level re  $10^{-12}$  Watt shall be less than 65 dB (A)/m<sup>2</sup>.

	client:	REMPEC			
	project:	Port Reception Facility			
	title:	Functional Specification Oily Waste Treatment			
office: Hengelo	Order: 33202	document: 3181001	rev.: B	sheet: 36	of: 49

## 6.8 Maintenance

The unit shall be designed to operate continuously and unattended with a minimum of inspection and maintenance. Time of uninterrupted operation will be at least two years. Tenderer's inspection and maintenance philosophy including detailed inspection and maintenance schedule shall be submitted with quotation.

	client:	REMPEC			
	project:	Port Reception Facility			
	title:	Functional Specification Oily Waste Treatment			
office: Hengelo	Order: 33202	document: 3181001	rev.: B	sheet: 37	of: 49

## 7 Specification for Civil Works

### 7.1 General Requirements

The Civil Works shall be designed according to modern internationally accepted codes. The buildings shall be constructed according to the quality requirements of this functional specification following accepted international standards, like ISO, EN, DIN, BS and/or AIA.

### 7.2 Demolition works

If demolition works are deemed to be necessary for the commencement of the Works, they shall be carried out in a careful manner in order to prevent further damages to adjacent structures and/or environment. All materials to be removed and demolished parts shall be dumped or prepared for recycling as directed by the Employer's Representative.

### 7.3 Earthworks

#### 7.3.1 Excavations

Excavation shall be carried out to such dimensions as will permit adequate dewatering, proper support of the sides of the excavation, the erection of shuttering, placing of concrete and fill including compacting and any other construction operation. The Contractor shall keep the excavations free from water from whatever source, so that the Works shall be constructed in dry conditions. He shall also prevent slips and falls of material from the sides of the excavations and embankments.

In the event of slips, or falls in the excavations the unsuitable material entered in the trench is to be removed and the additional backfilling that may be required. Water must be kept 500 mm under trench bottom.

#### 7.3.2 Supporting the Excavations

Because of the quality of the soil and especially when difficult ground water situations are present the Contractor shall take extra care when excavating adjacent to existing structures. In order to prevent collapsing the excavation walls and damages to the existing buildings, the Contractor shall be responsible for the supply and installation of steel sheet piles of sufficient strength and thickness to withstand driving, to obtain required locking, and to resist harmful distortion and/or buckling due to soil pressure.

### 7.4 Concrete and reinforcements

Structural concrete is made of Portland cement or where required or ordered, sulphate resisting cement and clean good quality aggregate. Concrete is classified according to 28-day compressive strength.

Concreting and after treatment (to prevent drying, protect from high temperatures and wind) of surfaces shall be made. Extra vibrating of upper parts of more deep than 0.4 m concrete casts shall be made about 2 hours after cast work to help concrete setting without cracks.



client:	REMPEC
project:	Port Reception Facility
title:	Functional Specification Oily Waste Treatment

#### 7.4.1 Water Proof Concrete

Water proof concrete for basins and reservoirs shall have a strength of minimum 40 N/mm<sup>2</sup>, water proof tested according to standards and water cement ratio maximum 0.49. The testing of waterproofing shall be made according to the codes and the results shall be presented to the customer. Structural design of water proof structures shall be made for easy casting and spaces for the vibrator. All concrete and reinforcement shall be designed for limited tensile stress to avoid cracks. Water proof construction joints must be equipped with injection tubes. Treatment of fresh water proof concrete surfaces shall be made to avoid fast drying.

Production of structural and water proof concrete shall be made by mechanical mixers and by weight batching. Water to be used for concrete shall be tested to standards. Quality control of concrete is made according to standards.

#### 7.4.2 Reinforcement

Bar reinforcement shall be of hot rolled high yield ribbed steel, grade minimum 400, or cold worked steel deformed bars grade minimum 500. Cold deformed bars shall come with certificate.

Reinforcement shall be clean and free from loose material, loose rust, grease and other which can weaken the bond. Welded reinforcement units shall be to standards.

Concrete cover of reinforcement shall be according to standards, in general minimum 35 mm in columns, beams and water proof structures. If applicable protective coatings shall be applied to concrete structures to protect concrete against acid ground water or other chemical attacks.

#### 7.4.3 Water retaining structures

The inside of shuttering shall be coated with non-staining mineral oil, mould cream emulsion or with other approved material which shall not be allowed to come into contact with adjacent concrete or the reinforcement.

Except where otherwise specified, shuttering for concrete faces which will remain exposed in the Permanent Works, shall be 'wrought' shuttering, i.e. it shall prevent the loss of any ingredients from the concrete and will produce a dense smooth surface without discontinuities of line, texture or appearance.

Also the shuttering for faces which will remain hidden in the Permanent Works, shall be 'back' shuttering, i.e. it shall prevent the loss of any ingredients from the concrete and will produce a dense concrete surface.



client:	REMPEC
project:	Port Reception Facility
title:	Functional Specification Oily Waste Treatment

#### 7.4.4 Finishing of Concrete Surfaces

All finishing work, either by means of a metal trowel or wooden float, shall be executed directly after the concrete has been cast and before the concrete is set.

The top surfaces of process basins, channels, gullies, walls and concrete fillings of structures which are not to be covered shall be floated off to a smooth finish by means of a flat steel trowel. Floor surfaces shall be floated off by strewing Portland cement onto the concrete surface.

#### 7.4.5 Brick and concrete block work

The bricks, blocks and mortar for exterior walls shall be sound, hard, well baked throughout their mass, have straight edges and be frost resistant. Mortars shall be lime-cement based. Reinforcement over openings shall be of stainless steel.

Bricks and profiles shall be of good quality, sound, hard, well baked, with uniform dimensions and shapes and of an approved type and colour.

Outside surface plasters shall be lime-cement based. Application shall be made in three layers, nominal thickness 20 mm, minimum 15 mm. First layer is splashing with maximum cover 80 %, second 15 mm and third 5 mm. The bond of plaster is to be minimum 0.3 N/mm<sup>2</sup>.

Sealing of facade concrete units and other joints is to be made by elastic polysulfide or polyurethane sealant material according to local standards and/or Euro-codes. A round polyethylene strip is applied to give good bottom shape for joint material. The bond to concrete, plaster, metal or other is controlled according to Standards.

#### 7.5 Roofing

Roofing felt shall comply with the local requirements. Extra guarantee of ten years of no leaking shall be applied to roof structures.

Each roof will be carefully inspected when ready. Roofs with inside water outlet are water tested with minimum 150 mm water near gullies

Where bitumen will be used the elasticity of SBS-bitumen roofing shall be min. 15 % for minus degrees in temperatures. Tensile strength of 2 layers of EPDM roofing is minimum 15 kN/m.

The minimum thickness shall be 1.2 mm and the elasticity 200 % at minus degrees temperature. Mechanical fixings and / or fixings by weight of granulate shall be applied. SBS-bitumen roofing shall be made of minimum 2 layers.



client:	REMPEC
project:	Port Reception Facility
title:	Functional Specification Oily Waste Treatment



Each layer is overlapped and bonded minimum width 100 mm. First layer is fixed by mechanical fixings or by hot bitumen bond according to base material. Second layer is fixed by flame welding 100 % of area.

The top layer shall be equipped with granulate chipping on top, also in cases of protective granulate layer on the roof.



client:	REMPEC
project:	Port Reception Facility
title:	Functional Specification Oily Waste Treatment

office: Hengelo	Order: 33202	document: 3181001	rev.: B	sheet: 41	of: 49
-----------------	--------------	-------------------	---------	-----------	--------

## 8 Specification for Electrical Works

### 8.1 General Requirements

All electrical equipment and installations shall be carried out in accordance with the requirements of the International Electro technical Commission Standard, European Committee for Electro technical Standardisation CENELEC and its Harmonisation Documents or equivalent National Standards.

The polarity and phase colours shall be according to the local electrical regulations. The electrical supply shall be one fused feed cable, three phase, neutral + earth.

The drawing symbols shall adhere with IEC standards.

### 8.2 Electrical equipment

#### 8.2.1 Switchgears

The following requirements shall be applicable to

- Main Low Voltage Switchgears of the buildings (MLVS)
- Motor Control Boards (MCB)
- Building Services Boards (BSB)
- Uninterrupted Power Supply (UPS)

Only internationally available equipment according to IEC 947 shall be selected. The construction shall meet the requirements set in standard IEC 439-1, as well as the following.

- General supply voltage, unless stated otherwise, shall be 400/240 V, 3-phase, 50 Hz.
- The degree of the protection shall be IP 54 inside buildings and IP 55 outside.
- Switchgears (MLVS, MCB, and BSB) shall be cubicle type (fixed or withdrawable) where the main feeders and motor starters shall be placed in cabinets having segregated spaces for each feeder and starter.
- The cubicles shall have hinged doors and shall be segregated from each other, supply busbars and cable cubicles, so that it is possible to work safely in one space while the other spaces are engaged.
- Each outgoing vertical switchgear section shall have an adjacent cable compartment running the full height of the switch gear.
- Minor switchboards may be multi-box or enclosed type.
- The boards will be assembled in the factory completed with internal wiring and equipment. All wires going out from the board, up to 10 mm<sup>2</sup> cross section, will end in terminal blocks. Bigger outgoing cables will be connected directly to the device.
- Also all control wires including reserve wires shall be connected to terminal blocks.
- Metallic parts of boards shall be connected to protective earth busbars or to earth terminals.

All boards shall be equipped with 20 % auxiliary distribution output relevant to total number in use. The plant shall be equipped with preliminary switchgear equipment and/or a Main Low Voltage Switchgear MLVS where necessary.



client:	REMPEC
project:	Port Reception Facility
title:	Functional Specification Oily Waste Treatment

The electrical cabinet shall as a minimum comprise the following:

- low voltage distribution;
- motor starter;
- overload protection;
- all necessary switches etc.

### 8.2.2 Electric Motors

All electric motors shall comply with the requirements of IEC.

Constant speed a/c. motors shall be of the induction type suitable for operation on a 3 phase supply and shall be capable of operating continuously, at rated torque, at any voltage between +5 and -10 percent of the nominal value, and nominal frequency +2 and -2 Hertz.

Motors of 0, 4 kV shall be of the squirrel cage rotor type suitable for direct-on-line starting having a starting current not greater than 6 times the full load current.

All motors shall be capable of running continuously at power not less than 10 % excess of that absorbed by the driven plant under any operating conditions. The reserve power requirements shall be added to the calculated power prior to any other adjustments e.g. high ambient temperature at site. In addition all motors of 0.4 kV shall be suitable for 10 starts per hour and motors 0, 6 kV 5 starts per hour.

Submersible pump motors shall afford a degree of mechanical protection not less than IP 68. Enclosures for other motors shall afford a mechanical protection not less than IP 54 for those installed indoor and IP 55 for those installed outdoor.

In location where is a danger of explosion shall the motors be Ex-protected. Variable speed motors rated above 15 kW shall be fitted with PTC type thermistors and all the leads of these thermistors shall be terminated inside a separate terminal box with IP 55 degree of protection, where the thermistors shall be connected in series.

All motors and starters shall be able to be controlled manually and automatically from the Control Room. Motors will be operating in an ambient temperature not exceeding 40 °C. Motor insulation shall be to class F, with the temperature rise (by resistance method) limited to 80 °C.

The motors sound pressure level shall not exceed 80 dB(A) at 1 metre. In addition, the motors shall run free from vibration and their rotors shall be perfectly balanced both statically and dynamically in an approved manner.

All motors shall be given corrosion resistant paint finishes and shall have corrosion resistant parts.

	client:	REMPEC			
	project:	Port Reception Facility			
	title:	Functional Specification Oily Waste Treatment			
office: Hengelo	Order: 33202	document: 3181001	rev.: B	sheet: 43	of: 49

### 8.2.3 Electric Actuators

Electrically operated actuators for valves shall be sized to guarantee closure at the maximum possible differential pressure. The safety margin of motor power available for unseating the door shall be at least 50 percent in excess of maximum closing torque at the nominal supply voltage. The closing and opening shall not be more than 2 minutes for each operation unless otherwise specified.

The electric motors shall be class F insulated and conform to the specification with a timer rating of 15 minutes or twice the valve stroking time whichever is the longer.

A hand wheel shall be provided for emergency operation and shall be arranged such that when the hand wheel is engaged the motor shall be automatically disconnected mechanically and electrically.

### 8.3 Cables

Power cables of 6 kV shall be PVC insulated and sheathed type typical for underground installations. Conductors shall be of high conductivity solid aluminium. Standards IEC 502 and CENELEC HD class 2. Power cables  $U < 1$  kV shall be PVC insulated and sheathed cables, with copper conductors when  $A < 16$  mm<sup>2</sup> and aluminium conductors when  $A > 16$  mm<sup>2</sup>. Standards are IEC 502 and CENELEC HD 603-3F.

Installation power cables and control cables shall be PVC insulated and sheathed cables rated voltage 450/750 V according to IEC 227. All control cables shall consist of a suitable number of conductors of Cu 1, 5.6 mm<sup>2</sup>.

Cable installation shall be done as follows:

- Cable trays shall be made with galvanised steel or aluminium, with perforations for ventilation or ladder constructed.
- The trays shall be affixed with factory made parts. Manufacturer's instructions shall apply for affixation point distances, such that deflection does not exceed 1/200 suspension length.
- Power cables shall be separated from cable trays then the instrument regulation cables. Unnecessary crossings shall be avoided by neatly laying the cables on the cable trays. The cables will be fastened with ties at bends.

Cable surface installation shall occur wherever installation rails or cable trays are not available. All cables below 1.5 m from the finished floor level, where the risk of damage is greatest, shall be covered with metallic protection. Surface mounted cables shall be affixed every 20 cm minimum, with either stove enamelled or plastic covered clips. In concrete constructions the clips will be fixed in plastic or plugs with galvanised steel screws. Expansion bolts shall be used when the bearing capacity exceeds that of the plastic clips. If there are three or more parallel cable groups, plastic covered or galvanised steel cleats shall be used. Cable clips for group cleats shall be plastic with galvanised steel screws.



client:	REMPEC
project:	Port Reception Facility
title:	Functional Specification Oily Waste Treatment

Underground cables shall be installed in cable trenches approximately 0.7 m below the surface with plastic flute protection. The cables shall be imbedded in stone free soil. They shall be laid on a smooth bottomed trench and covered with approximately 200 mm of sand. A plastic caution band shall be placed above the cables, at 0.3 m depth.

## 8.4 Lighting

Proper lighting promotes safe working conditions, good housekeeping. Lighting is required both inside structures and outside.

For inside lighting, the fullest possible use should be made of natural lighting through windows and skylights. Architectural treatment can do much to improve natural lighting. Artificial lighting is important where many operations have to be conducted during the hours of darkness. Direct lighting from high fixtures avoids glare, while indirect lighting is useful in laboratories and offices. Fixtures should be located so as to be easy of access. Means should be provided whereby high fixtures, such as those outdoors, can be reached or such fixtures should be fitted to units that can be lowered.

In those areas of the plant where moisture may be present, lighting fixtures should be vapour-tight and dust-proof. In enclosed locations, explosion-proof fixtures are required.

Outside lighting is important, as much of the treatment plant is outdoors, and operating platforms and tank walkways are frequently used by operators. Particular attention must be given to outdoor stairways, ladders, building entrances, and outdoor equipment.

In general, indoor lighting should provide 350-450 lux in equipment rooms and 550-850 lux in offices and laboratories. Outside lighting should be in the range 20-50 lux, depending on extent of use and on safety requirements. The lighting of operating stations outdoors should provide 160-220 lux.

Emergency lighting shall be applied in process areas where a break in working lighting may cause harm for process activities. Evacuation lighting shall be installed in the areas such as stairs, corridors etc. with a minimum illumination level of 0.5 lux.

All lighting will mainly be carried with fluorescent fittings. The degree of protection for the fittings will be:

- in process rooms: IP 44;
- in technical rooms: IP 34;
- in aggressive rooms: IP 65 or Ex-protected when needed.

## 8.5 Earthing

The earthing in the buildings shall be carried out according to the National Standards.

	client:	REMPEC			
	project:	Port Reception Facility			
	title:	Functional Specification Oily Waste Treatment			
office: Hengelo	Order: 33202	document: 3181001	rev.: B	sheet: 45	of: 49

## 9 Specification for Instrumentation and Control

### 9.1 General Requirements

The minimum level of the instrumentation and automation works of the treatment plant will more closely be described by the Tenderer in a Process Flow Diagram annexed to this Tender.

The instruments, cabling and equipment shall be designed, manufactured and installed to ensure the highest standard of operational reliability, suitability for the prevailing ambient conditions at the site and shall be obtained from the manufacturer who has existing adequate facilities, staff and spare parts locally for servicing and maintaining them.

Equipment shall be arranged so that individual equipment may be removed without disturbing the remaining equipment of process operation.

### 9.2 Measuring Equipment

#### 9.2.1 Flow meters

The flow of untreated and treated sewage in closed conduit can be measured by:

- ultrasonic flow meter;
- electromagnetic flow meter.

The open channel flow measurement can be translated to level or level difference measurement with either venturi flume or V-notch weir (and are specified in appropriate section) by:

- ultrasonic level metering;
- pressure level/level difference metering;
- bubbling tube level metering.

#### 9.2.2 Electromagnetic flow meter

The electromagnetic flow meters shall comply with the following specifications:

Number:	(*) according to Tenderer's specification
Temperature range:	-2 ... +50 °C
Method of measurement:	electromagnetic flow meter
Measuring range:	according to design
Accuracy:	< ±0.5 % of measured value
Repeatability:	< ±0.1 % of measured value
Output signal:	4 - 20 mA, galvanically isolated
Protection:	IP 65
Power supply:	240 VAC, power feed from nearest distribution board
Other devices:	display in six numbers for actual and cumulative flow indication in [m <sup>3</sup> /h]
Installation:	according to design

### 9.2.3 Ultrasonic flow meter

The ultrasonic flow meters for closed conduits shall comply with the following specifications:

Number:	(*) according to Tenderer's specification.
Temperature range:	-2 ... +50 °C
Method of measurement:	ultrasonic flow meter
Measuring range:	according to design
Accuracy:	< ±0.5 % of measured value
Repeatability:	< ±0.1 % of measured value
Output signal:	4 - 20 mA, galvanically isolated
Protection:	IP 65
Power supply:	240 VAC, power feed from nearest distribution board
Other devices:	display for actual and cumulative flow indication in m <sup>3</sup> /h
Installation:	according to design

### 9.2.4 Ultrasonic level meter

The ultrasonic level meters shall comply with the following specifications:

Number:	(*) according to Tenderer's specification
Method of measurement:	ultrasonic level meter or for flow in open conduits
Temperature range:	-2 ... +50 °C
Measuring range:	according to design
Accuracy:	< ±0.5 % of measured value
Repeatability:	< ±0.1 % of measured value
Response time:	< 10 sec.
Output signal:	4 - 20 mA, galvanically isolated
Protection:	IP 65
Power supply:	240 VAC, power feed from nearest distribution board
Other devices:	display for actual and cumulative flow indication in m <sup>3</sup> /h
Installation:	according to design

### 9.2.5 Piezoresistive pressure level meter

The piezometric level meters shall comply with the following specifications:

Number:	(*) according to Tenderer's design
Method of measurement:	piezoresistive pressure transducer
Temperature range:	-2 ... +50 °C
Measuring range:	according to design
Accuracy:	< ±0.5 % of measured value
Repeatability:	< ±0.1 % of measured value
Response time:	< 1 sec.
Output signal:	4 - 20 mA, 2-wire
Protection:	IP 65
Power supply:	240 VAC, power feed from nearest distribution board
Other devices:	display for actual level indication in [m]. Three (3) limit switch units with two (2) changeover outputs relay per unit.
Installation:	according to design

### 9.2.6 Level switches

The level switches shall be of floating type switches. The level switches shall operate on 24 V dc voltage.

### 9.2.7 Design

All field instruments shall be IP55-enclosed and equipped with tagged nameplates. Tag numbers to be supplied by Employer. Accuracy must be at least 1% full scale. The instruments shall operate on 24 VDC. The power supply to Tenderer will be 220/230-380/400V, 50 Hz. All instruments shall be lined-up completely with ½" steel impulse lines using compression type fittings. Used bracket material shall be steel.

All instruments using instrument air shall be supplied with filter/pressure reducer and air supply pipeline. The sub air header shall be furnished with a shut-off valve to the main air header.

All instruments will be electrically connected via an IP54-enclosed instrument junction box towards the fully wired local control panel. All single cable shall run between each skid and the control panel. The cables shall be numbered according to the instrument tag numbers.

The local panel shall be furnished with all the lamps, push buttons and indicators/controllers for all applied instruments. The interface to the 'plant control system' consists of a 'system failure' all tendered (potential free) via a terminal in the local panel.

Measurement units shall to be according to SI standards.

- Flow m<sup>3</sup>/h
- Volume m<sup>3</sup>
- Level %
- Low pressure mbar
- Pressure bar
- Temperature °C
- Frequency Hz
- Currents A
- Voltage V

All process information shall be connected to programmable logic controller (PLC). The PLC shall control all the process equipment. The PLC shall be installed in a separate (air conditioned) control room.

From all equipment which shall be controlled by the PLC shall be connected the minimum information to the PLC as follows:

- position of the control switch: 2xDI (digital input)
- run information: 1xDI
- alarm information: 1xDI
- control: 1xDO (digital output)



client:	REMPEC
project:	Port Reception Facility
title:	Functional Specification Oily Waste Treatment



The PLC shall be in compliance with the following technical requirements:

- modular structure for enlarging;
- EEPROM or adequate memory backup;
- on-line programming;
- real time clock;
- real time calendar;
- serial RS 232 C interface for radio modem for data communications;
- serial RS 232 C interface for PC (for monitoring the state of technological process, changing control values and programming PLC);
- built-in communication software.

The Contractor shall provide an instrumentation earthing system. Each instrumentation system or group of instruments shall be connected individually to this earthing via insulated copper earth cables sized for the maximum prospective fault current. This earthing system shall be independent and shall not form part of the general plant earthing system.

### 9.3 Automation Works

All program outputs, alarms, legends, labels and other text format data shall be in English and French language. In normal circumstances process shall be controlled automatically by control system with no operating staff. Alarm points shall be programmable to three alarm emergency classes. The PLC shall bear the readiness for the remote control by the central computers later on.

All equipment and measuring instruments connected to the local automation system shall be equipped with possibility to be monitored on the graphic display for supervision. All measuring and set points shall be ready for monitoring in pre-programmed trend displays.

The PLC shall be equipped with power system to retain the software and operation readiness during the power failures and the system shall be designed so that after the cut-off the plant shall start automatically.

Normal voltage 240 V AC, 50 Hz, shall be fed to the PLC.

The basic functions of the PLC program are as follows:

- controlling the process;
- calculating the running time of the machines;
- counting the number of starts and stops;
- calculating/counting the flows;
- calculating the energy consumption;
- generating the alarm signals;
- processing the data storage;
- data communication with the control system;
- visualisation of the process.



client:	REMPEC
project:	Port Reception Facility
title:	Functional Specification Oily Waste Treatment

## **Appendix B: Functional specification for Transfer Stations of Garbage**

- document number 3381001, rev. A.

## Functional Specification for Transfer Station for Garbage

A	08-10-2004 27-08-2004	Final updated	HH	ALUW
0	17-06-2004	Comments	ASVK	ALUW
rev.	date	description / issued for	author	ckd.
	client: REMPEC			
	project: MED.B7.4100.97.0415.8			
	title: Functional Specification Transfer Station for Garbage			
office: The Hague		Order: 33202	document: 3381001	rev.:A
		sheet: 1	of: 22	

<b>Table of contents</b>	<b>page</b>
Table of contents	2
Definitions	4
<b>1 General Requirements</b>	<b>5</b>
1.1 Introduction	5
1.2 Scope of Work	6
1.3 Information	7
1.4 Coordination and Inspections	7
<b>2 Description of the Works</b>	<b>8</b>
2.1 Design Basis	8
2.1.1 Waste Characteristics	8
2.1.2 Location and access	8
2.2 Guarantees	8
2.3 Detailed Design	9
2.4 Inspections	9
<b>3 Employer's Requirements</b>	<b>10</b>
<b>4 General Specifications</b>	<b>11</b>
4.1 Responsibility	11
4.2 Standards and Regulations	11
4.3 General Requirements	11
4.4 Documentation	12
4.4.1 Documents for regulatory approvals by relevant authorities	12
4.4.2 As-built drawings	12
4.4.3 Review and Approvals of design documents	12
4.5 Take Over	12
<b>5 Specification for Civil/Structural Works</b>	<b>13</b>
5.1 General Data and Requirements	13
5.2 Demolition Works	13
5.3 Earthworks	13
5.3.1 Excavations	13
5.3.2 Supporting the Excavations	13
5.3.3 Backfill	13
5.4 Concrete and reinforcement	13
5.4.1 General	13
5.4.2 Materials	14
5.4.3 Formwork	14
5.4.4 Finishing of Concrete Surfaces	14
5.5 Structural steelwork and cladding	14
5.5.1 General	14
5.5.2 Materials	14
5.5.3 Roof sheeting and cladding	15

5.5.4 Roof gutters	15
5.6 Paving and fencing	15
5.6.1 Paving	15
5.6.2 Sewer system	15
5.6.3 Fencing and gate	16
<b>6 Specification for Electrical Works</b>	<b>17</b>
6.1 General Requirements	17
6.2 Electrical equipment	17
6.2.1 Switchgears	17
6.2.2 Electrical installations	18
6.3 Electrical cabling	18
<b>7 Specification of Equipment</b>	<b>19</b>
7.1 Containers	19
7.2 Compacting equipment	21
7.3 Receptacles	22



client:	REMPEC				
project:	MED.B7.4100.97.0415.8				
title:	Functional Specification Transfer Station for Garbage				
office: The Hague	Order: 33202	document: 3381001	rev.: A	sheet: 3	of: 23

## Definitions

The following notes and expressions in this specification shall have the meaning hereby assigned to them for the purpose of this request except where the context otherwise requires:

**'Government'** means the Government of ..... and its authorized agents.

**'Employer'** means the National Organization issuing the Tender Documents for these works.

**'Works'** and **'Permanent Works'** means all Plant to be provided and all work to be executed in accordance with the Contract including if necessary the design, manufacture, delivery, supply, erection, construction setting to work, commissioning, testing, operation and maintenance.

**'Temporary Works'** means all temporary works of every kind required in or about the execution of the Works.

**'Specification'** means the technical specification according to which the works are to be executed referred to in the Contract Documents and any other specification agreed thereon.

**'Tenderer'** means the Company who delivers a proposal on behalf of this invitation for tendering.

**'Contractor'** means the person or persons, firm or company whose proposal has been accepted by the Employer and includes the Tenderer's authorized representatives, successors and permitted assigns.

**'Sub-Contractor'** means any person or persons, firm or company entering into an agreement with the Contractor for performance of work under this Assignment.

**'Terms of Reference'** (ToR) means the statement issued by the Employer giving the definition of its requirements and objectives of the services, including, where applicable, the methods and means to be used and/or results.

**'Schedule'** means the Schedule or Schedules in which the Works are described for the purpose of evaluating the items of the Works to be executed under the Assignment by the Contractor.

**'Site'** means the land and other places, on, under, in or through which the Works are to be executed or carried out and any other lands or places provided by the Employer for the purposes of the assignment together with such other places as may be specifically designated in the Contract as forming part of the Site.

Words implying persons or parties shall include firms and corporations. Words implying the singular only also include the plural and vice versa where the context requires.

	client:	REMPEC			
	project:	MED.B7.4100.97.0415.8			
	title:	Functional Specification Transfer Station for Garbage			
office: The Hague	Order: 33202	document: 3381001	rev.: A	sheet: 4	of: 23

# 1 General Requirements

## 1.1 Introduction

The implementation of MARPOL 73/78 Convention for prevention of pollution from illegal discharges into the sea is one of the main concerns relating to prevention of pollution from ships in the Mediterranean Sea. Even though accidental marine pollution still attracts major public attention, operational pollution by illegal discharges of ships into the sea is the main source of pollution of the marine environment.

The IMO/UNEP Regional Marine Pollution Emergency Response Centre for the Mediterranean Sea (REMPEC), a Regional Activity Centre within the Mediterranean Action Plan (MAP) of the United Nations Environment Program (UNEP) administered by the International Maritime Organization (IMO), is currently implementing an EU funded MEDA Project on port reception facilities for collecting ship-generated garbage, bilge waters and oily wastes in the Mediterranean (MED.B7.410097.0415.8). This project contains several activities.

Activities A and C of the project assessed the present situation of port reception facilities in the involved countries, while Activity B presented the solution for collection, treatment and disposal of relevant types of ship generated solid and liquid waste for a number of relevant ports/terminals. The reporting of activity B compiled experiences of port reception facilities in many ports worldwide as well as waste management techniques (BAT – Best Available Techniques).

The report of Activity A suggested that the following ports might need a garbage transfer station:

- Alexandria (Egypt);
- Limassol (Cyprus);
- Valetta (Malta);
- Bodrum (Turkey);
- Skikda (Algeria).

This Technical Specification, part of Activity D of the project, represents the functional specification of the required garbage transfer facilities in the ports mentioned above.

Drawings showing Typical layout and Section of Garbage Transfer Stations for respectively garbage quantities of  $\leq 1000$ ,  $1000 - 2000$  and  $\geq 2000$  m<sup>3</sup> per year are attached to this specification.

Collection of wastes from ships is in many ports done by private contractors. In a number of ports additional collection equipment such as trucks and barges is recommended in the reports of Activity A and C. However, the modifications or extensions of these collection activities are not part of this specification.



client:	REMPEC
project:	MED.B7.4100.97.0415.8
title:	Functional Specification Transfer Station for Garbage

This technical specification, Activity D of the Project, was developed with the objective that the National Organisation issuing the Tender Documents, hereunder referred to as the 'Employer', either finances the construction of the facilities, or seeks funding from donor agencies and financial institutions for the setting up of facilities for the reception and transfer of garbage in typical facilities with standard capacities.

The cost of building/constructing reception facilities will include the costs of the material purchased from overseas under Design-Built type contract, as well as additional works conducted locally for the entire reception and treatment facilities. These Employers Requirements will concern the modules to be delivered and the work to be conducted for the realization of the entire reception and transfer stations in the relative ports.

## 1.2 Scope of Work

It is the intention of the Employer to place a Contract at later stage for the whole or a part of the works in accordance with a Tendering package, in which detailed duty specifications have been developed on the basis of these functional specifications or after a tender based only on this specification.

For this purpose the Employer issues the 'Operational and Functional Design Criteria' of the project in this Functional Specification.

The scope of services and supply shall comprise, but is not limited to, the following:

- the detailed design, construction, supply and installation and handing over to the Employer a complete, reliable, safe and operational system including all items, services and documentation;
- a detailed description of each part of the equipment offered;
- a description of the design principles and the construction materials;
- quality and safety objectives and operational conditions;
- a description of the method of operation;
- the relevant standards applicable to the design and construction;
- listing of applicable international and local law pertaining the complexity of the plant and environmental conditions.
- a computation of equipment capacities and sizing where required;
- a listing of particular guarantees;
- a complete set of detailed drawings;
- a training schedule for the Employer's personnel in operation and maintenance;
- a time schedule for completion.

The Tenderer is required to submit a Tender which fully complies with this Specification and with the Conditions of Contract, included in the Tender Package.

	client:	REMPEC			
	project:	MED.B7.4100.97.0415.8			
	title:	Functional Specification Transfer Station for Garbage			
office: The Hague	Order: 33202	document: 3381001	rev.: A	sheet: 6	of: 23



On the condition that a Tender is submitted in accordance with the above, the Tenderer may submit an alternative technical proposal. The alternative proposal must be submitted as an alternative Tender and the deviations from the specified requirements must be clearly stated. The Tenderer shall also state the justification for the proposed deviations. The alternative technical proposal shall be separately priced by the Tenderer in order to enable the Employer to assess the alternative proposal.

### 1.3 Information

Before submitting his Tender the Tenderer shall be deemed to have inspected the Site and its surroundings and to have satisfied himself completely as to the nature of the ground and sub-soil, the hydrological and climatic conditions, the form and nature of the site, the quantities and nature of the Work and materials necessary for completion of the Works and the means of access to the Site by land and sea. Also the Tenderer shall have obtained all necessary information as to risks, contingencies and other circumstances which may influence or affect his Tender.

### 1.4 Coordination and Inspections

In order to ensure that the public health and environmental requirements will be met during the implementation of the project the Employer shall appoint an 'Engineer' to represent the Employer and to carry out duties specified in the Contract Documents. The Contractor shall also nominate a responsible representative in his Tender.

	client:	REMPEC			
	project:	MED.B7.4100.97.0415.8			
	title:	Functional Specification Transfer Station for Garbage			
office: The Hague	Order: 33202	document: 3381001	rev.: A	sheet: 7	of: 23

## 2 Description of the Works

The works comprise a transfer station for garbage, consisting of a concrete paved ramp leading to a concrete platform. The platform shall have a canopy consisting of a light steel structure covered with corrugated steel sheeting. Garbage collection trucks shall drive onto the platform and discharge the garbage in larger waste containers (e.g. 40 m<sup>3</sup>) located around the platform.

The site around the platform shall be asphalt paved, except for the location of the containers, which shall have a liquid-tight concrete paving. A rain water system, connected to the communal system, shall be incorporated in the asphalt paving. The potentially contaminated water from the concrete paving shall be collected in a concrete pit, which is to be emptied by a vacuum truck.

The site shall be lighted as well as the platform under the canopy.

Around the site a wire link fence shall be installed with a double access gate. The site shall be connected to the local road system by means of a surfaced access road.

Local conditions may have an impact on the design of the facilities for a specific site. It is therefore at the Tenderers discretion to collect information as stated in section 1.3.

### 2.1 Design Basis

#### 2.1.1 Waste Characteristics

Density: .....kg/m<sup>3</sup>  
Moisture content: .....%

#### 2.1.2 Location and access

The port ..... is located in ..... on the ..... Sea, approximately ..... km from the city of ..... The location of the site is shown in the drawings attached to this Tender.

Weather conditions are as follows:

Maximum annual temperature ..... °C  
Minimum annual temperature ..... °C  
Mean annual temperature, about ..... °C  
Annual rainfall, approx. .... mm

### 2.2 Guarantees

Contractor shall guarantee that the facilities offered will be free from deficiencies in design, materials and workmanship and will perform satisfactorily for the specified purpose.

## 2.3 Detailed Design

Before commencing any part of the Works the Contractor shall submit his detailed design for approval to the Engineer. The detailed design shall be unambiguous and facilitate the assessment of the technical execution.

The grading elevation of the transfer station, connected to the location is an important factor in its successful operation. The grading must provide protection against storms and natural drainage patterns must be used as far as possible.

The access road and the location of the facilities must meet the operational requirements. Conceptual layouts of the transfer station are given on drawing number 33002050/33002051/33002052. A total number of three typical lay-outs of garbage transfer stations for different quantities of garbage is presented.

## 2.4 Inspections

The facilities shall be regularly inspected by the Employer during construction. Sufficient inspections shall be made to ensure that the materials and construction comply in all respects with the requirements of the local and national authorities and this specification. Any approval given by an Inspection Authority or by the Employer does not absolve the Contractor from his responsibility for the Works.

	client:	REMPEC			
	project:	MED.B7.4100.97.0415.8			
	title:	Functional Specification Transfer Station for Garbage			
office: The Hague	Order: 33202	document: 3381001	rev.: A	sheet: 9	of: 23

### 3 Employer's Requirements

The Government of ..... has decided to implement a ship-generated garbage transfer station for the port of .....

In accordance with the MEDA Project, Reports A, B and C (port reception facilities for collecting ship-generated garbage, bilge waters and oily wastes in the Mediterranean) this Specification provides the functional requirements of a garbage transfer station.

The transfer station consists of the following main components:

- a ramp for garbage collection trucks to access the platform;
- a raised platform from which the garbage is tipped in larger containers.

The garbage shall be delivered to the transfer station by local waste collection companies. The delivery circumstances are specific for each port location and must be clarified in detail with the Employer.

	client:	REMPEC			
	project:	MED.B7.4100.97.0415.8			
	title:	Functional Specification Transfer Station for Garbage			
office: The Hague	Order: 33202	document: 3381001	rev.: A	sheet: 10	of: 23

## 4 General Specifications

### 4.1 Responsibility

The Contractor is responsible for the completeness and accuracy of his design calculations and for compliance with the requirements of this Specification.

If during the Tender preparation unexpected factors may arise which in the judgment of the Tenderer justify deviation from the specified requirements, the Tenderer may propose an alternative and be bound by the same conditions, so far as applicable, as though the said alternatives were stated in this Specification.

The Contractor shall in the execution of work on Site observe and comply with and be bound by the national laws.

### 4.2 Standards and Regulations

As a minimum requirement materials and workmanship shall comply with the latest issue of the National or International Standards or Code of Practice as referred to in this Specification, or comply with alternative equivalent internationally recognized Standards.

Full details in English/French/national language of proposed alternative equivalent internationally recognized standards for works shall be provided with the Tender by the Tenderer.

All materials, construction, inspection, testing and all aspects of design shall be in compliance with:

- a) Codes and Standards as defined above;
- b) current Good Engineering Practices;
- c) European Directives (if applicable).

All possible measures and precautions shall be taken into account in the design as well as during the construction works that operation, maintenance and service can take place without hazards to the operational personnel.

Construction equipment shall also be used which will minimize the risk of occupational physical hazards for the construction personnel.

### 4.3 General Requirements

Battery limits are basically defined at:

- Fused feed cable;
- Access road connection to municipal road system;
- Rain water discharge connection to municipal sewer if any.

Tenderer is requested to define any further battery limits in detail in his Tender.

As part this Contract the Contractor shall order a geotechnical soil investigation with a specialized firm in order to define the foundation type of the platform and ramp.

#### **4.4 Documentation**

All design documentation shall be furnished in the National language, English or French. The approval of drawings, calculations and welding procedures by the Employer does not release the Contractor of his overall responsibility for the whole of the works.

##### **4.4.1 Documents for regulatory approvals by relevant authorities**

The Contractor shall prepare drawings and the documentation necessary for the application of official permits, certificates, regulatory approvals and licences from relevant authorities. The Employer shall assist in obtaining the permits and official approvals. All costs related to the application of official permits and approvals shall be included in the Contract.

##### **4.4.2 As-built drawings**

The Contractor shall prepare as-built documentation of each part of the Works as part of the Contract.

##### **4.4.3 Review and Approvals of design documents**

All drawings, calculations and documentation to be prepared by the Contractor under the Contract shall be submitted to the Engineer for approval in 5-fold.

Comments on the design documentation by the Engineer, if any, shall be revised on the documents by the Contractor and resubmitted.

All fabrication and construction works shall only be carried out after approval by the Employer of the design documentation.

All costs, related to the supply to the Engineer of the mentioned number of drawings and calculations, shall be included in the Contract.

#### **4.5 Take Over**

The take-over procedure and completion of outstanding work with remedying defect shall follow the procedures as laid down in the Conditions of Contract. The maintenance period for the works shall be 12 months



client:	REMPEC
project:	MED.B7.4100.97.0415.8
title:	Functional Specification Transfer Station for Garbage

## 5 Specification for Civil/Structural Works

### 5.1 General Data and Requirements

The civil/structural works shall be designed and constructed according to the quality requirements of this functional specification following accepted international standards, such as ISO, EN, DIN, BS and/or AIA.

### 5.2 Demolition Works

If demolition works are necessary for the implementation of the Works, they shall be carried out in a careful manner in order to prevent damages to adjacent structures and/or environment. All materials to be removed and demolished parts shall be dumped as directed by the Engineer.

### 5.3 Earthworks

#### 5.3.1 Excavations

Excavations shall be carried out to such dimensions as will permit adequate dewatering, proper support of the sides of the excavation, the erection of shuttering, placing of concrete and fill including compacting and any other construction operation. The Contractor shall keep the excavations free from water from whatever source, so that the Works can be constructed in dry conditions.

#### 5.3.2 Supporting the Excavations

Contractor shall take all necessary measures when excavating adjacent to existing structures in order to prevent damage to these existing buildings.

#### 5.3.3 Backfill

Backfill for the site and access road shall be clean sand and/or a mixture of clean sand and gravel to be compacted adequately for the approval of the Engineer.

### 5.4 Concrete and reinforcement

#### 5.4.1 General

The materials and construction of the reinforced concrete ramp and platform shall be in accordance with relevant European norms (EN) or equivalent.



client:	REMPEC
project:	MED.B7.4100.97.0415.8
title:	Functional Specification Transfer Station for Garbage

#### 5.4.2 Materials

Bar reinforcement shall be of hot rolled high yield ribbed steel, grade minimum 400, or cold worked steel deformed bars grade minimum 500. Reinforcement shall be clean and free from loose material, loose rust, grease and other which can weaken the bond. Welded reinforcement units shall be to standards.

Concrete cover of reinforcement shall be according to standards; in general minimum 40 mm. Concrete quality shall be minimum B35.

The mixture composition of cement, aggregate and water of the concrete shall be determined to meet the required strength, exposure conditions and desired workability.

#### 5.4.3 Formwork

The inside of shuttering shall be coated with non-staining mineral oil, mould cream emulsion or with other approved material which shall not be allowed to come into contact with adjacent concrete or the reinforcement.

#### 5.4.4 Finishing of Concrete Surfaces

All finishing work, either by means of a metal trowel or wooden float, shall be executed directly after the concrete has been cast and before the concrete is set.

All external corners of the concrete to be chamfered 20 mm.

### 5.5 Structural steelwork and cladding

#### 5.5.1 General

All structural steelwork shall be designed according to the relevant European norms or equivalent.

The canopy for the platform shall be designed, supplied and installed, complete with fasteners, anchor bolts, grouting, flashings, gutters, etc. All connections of the structural steel members shall be bolted. No field-welding is allowed.

#### 5.5.2 Materials

The steel structure for the canopy shall be steel quality S235JR92 according to the European norms (EN) and hot dip galvanized with the following requirements:

- $Si\% \leq 0.03$
- $Si\% + 2.5P \leq 0.09$

All materials shall be of new stock and the surfaces of the profiles shall meet the requirements of ISO 8501-1, grade A or B. Bolts shall be grade 8.8 and hot dip galvanized.



client:	REMPEC
project:	MED.B7.4100.97.0415.8
title:	Functional Specification Transfer Station for Garbage



### 5.5.3 Roof sheeting and cladding

Sheeting for the roof and sidings of the platform canopy shall be corrugated steel sheeting, cold formed and sendzimir galvanized, with minimum thickness of 0.7 mm.

The sheeting shall be pre-painted on both faces with a PVDF-coating, thickness 25 micron, color in consultation with the Engineer.

Flashings shall be sendzimir galvanized steel sheet minimum 0.7 mm thick, prepainted identical to the cladding.

### 5.5.4 Roof gutters

Roof gutters along the roof of the canopy shall be rectangular shaped, with minimum dimensions  $b \times h = 250 \times 125$  mm, and made of identical material as the flashings.

The down-pipes shall be PVC.

## 5.6 Paving and fencing

### 5.6.1 Paving

The top surface of the platform and ramp shall be part of a concrete structure and shall be brush-finished in order to create a rough surface to provide sufficient grip for the tires of the garbage collection trucks.

The area where the containers are to be placed is to be paved with a concrete paving designed for heavy traffic and with a hardened top layer to withstand damage from the handling of the containers.

The remaining surface of the site shall have asphalt paving on a suitable base layer, designed and constructed for heavy traffic.

All paving design and construction shall be for approval of the Engineer.

### 5.6.2 Sewer system

The concrete paving area, where the containers are to be located, shall be provided with a waste water system for potentially contaminated water.

The system consists of prefabricated concrete catch basins with removable ductile iron inlet grilles mounted on ductile iron frames, suitable for heavy traffic. The catch basins shall form an integral part of the paving with water-tight connections. The connecting piping shall be HDPE suitable for heavy traffic.

The collection pit for the waste water shall be a prefabricated concrete pit, volume  $6 \text{ m}^3$ , with a ductile iron manhole cover and frames, suitable for heavy traffic.



client:	REMPEC
project:	MED.B7.4100.97.0415.8
title:	Functional Specification Transfer Station for Garbage

The asphalt paving of the site shall be provided with a rain water system consisting of prefabricated concrete catch basins, with removable ductile iron inlet grilles and frames, suitable for heavy traffic and connected with PVC-piping. The site rain water system shall be connected to the municipal sewer system.

### 5.6.3 Fencing and gate

The fence around the site shall be of the chain link wire netting type, 2300 mm high including three barbed wires, with posts, wires and braces.

The double swing gate shall be 6 m wide and consist of chain link wire netting type, 2250 mm high, with posts, wires, braces and struts.

The gate shall be provided with a safety lock.

	client:	REMPEC			
	project:	MED.B7.4100.97.0415.8			
	title:	Functional Specification Transfer Station for Garbage			
office: The Hague	Order: 33202	document: 3381001	rev.: A	sheet: 16	of: 23

## 6 Specification for Electrical Works

### 6.1 General Requirements

All electrical equipment and installations shall be carried out in accordance with the requirements of the International Electro technical Commission Standard, European Committee for Electro technical Standardization CENELEC and its Harmonization Documents and local electrical regulations.

The polarity and phase colors shall be according to the local electrical regulations. The electrical supply shall be one fused feed cable, three phase, neutral + earth.

The drawing symbols shall adhere with IEC standards.

### 6.2 Electrical equipment

#### 6.2.1 Switchgears

The following requirements shall be applicable to the Main Low Voltage Switchgears of the buildings (MLVS).

Only internationally available equipment according to IEC 947 shall be selected. The construction shall meet the requirements set in standard IEC 439-1, as well as the following:

- general supply voltage, unless stated otherwise, shall be 400/240 V, 3-phase, 50 Hz, neutral grounded;
- the degree of the protection shall be IP 44;
- minor switchboards may be multi-box or enclosed type;
- the boards will be assembled in the factory completed with internal wiring and equipment. All wires going out from the board, up to 10 mm<sup>2</sup> cross section, will end in terminal blocks;
- also all control wires including reserve wires shall be connected to terminal blocks;
- all board compartments where there are fuses and timers will be equipped with hinged covers;
- metallic parts of boards shall be connected to protective earth busbars or to earth terminals.

All boards shall be equipped with 20 % auxiliary distribution output relevant to total number in use. The plant shall be equipped with only one Main Low Voltage Switchgear MLVS.

The electrical cabinet shall as a minimum comprise the following:

- low tension distribution;
- overload protection;
- fuses;
- all necessary switches etc.

### 6.2.2 Electrical installations

Sufficient lighting shall be provided. The level of outside lighting shall be at least 20 lux on roads and paving and 150 lux under the canopy. Switching on/off outside lighting shall be by means of dark/light automatic system. Also manual switching shall be possible.

Provide sufficient wall sockets for maintenance purposes. The applicable standards are IEC 364 and CENELEC HD 384 or equivalent.

### 6.3 Electrical cabling

Power cables  $U < 1$  kV shall be PVC insulated and sheathed cables, with copper conductors when  $A < 16$  mm<sup>2</sup> and aluminum conductors when  $A > 16$  mm<sup>2</sup>.

Standards are IEC 502 and CENELEC HD 603-3F.

Installation power cables and control cables shall be PVC insulated and sheathed cables rated voltage 450/750 V according to IEC 227.

Cable surface installation shall occur wherever installation rails or cable trays are not available. All cables below 1.5 m from the finished floor level, where the risk of damage is greatest, shall be covered with metallic protection. Surface mounted cables shall be affixed every 20 cm minimum, with either stove enameled or plastic covered clips. In concrete constructions the clips will be fixed in plastic or plugs with galvanized steel screws. Expansion bolts shall be used when the bearing capacity exceeds that of the plastic clips. If there are three or more parallel cable groups, plastic covered or galvanized steel cleats shall be used. Cable clips for group cleats shall be plastic with galvanized steel screws.

Underground cables shall be installed in cable trenches approximately 0.7 m below the surface with plastic flute protection. The cables shall be imbedded in stone free soil. They shall be laid on a smooth bottomed trench and covered with approximately 200 mm of sand. A plastic caution band shall be placed above the cables, at 0.3 m depth.



client:	REMPEC
project:	MED.B7.4100.97.0415.8
title:	Functional Specification Transfer Station for Garbage

## 7 Specification of Equipment

### 7.1 Containers

The steel containers shall be suitable for transport of waste over larger distances. The containers shall be liquid proof. The design, content and maximum loading capacity shall be defined locally, depending on the design of available local trucks and local road transport regulations.

Figure 7.1 and Figure 7.2 show 30 and 40 m<sup>3</sup> containers for transport from the transfer station to the disposal site.



Figure 7.1: 30 m<sup>3</sup> bulk container



Figure 7.2: 40 m<sup>3</sup> bulk container

Figure 7.3 and Figure 7.4 show different demountable systems for containers on trucks. The first picture is a cablelift system, the second one a hook system.



Figure 7.3: Cable lift system



Figure 7.4: Hook lift system

## 7.2 Compacting equipment

In order to reduce the storage capacity and the number of shipments from the transfer station to the final disposal site, compacting equipment can be considered. This compacting equipment can be installed in the garbage transfer station and hydraulic cylinders push the garbage into closed waste containers. By pushing the waste into the container the waste is compacted.

A stationary press consists of:

- a chute;
- a press with coupling devices to containers;
- a hydraulic unit.

These units are on the market as complete package units.

Figure 7.5 shows an example of a stationary press.



Figure 7.5: Stationary press connected to a press container

 <b>TEBODIN</b> Consultants & Engineers	client:	REMPEC			
	project:	MED.B7.4100.97.0415.8			
	title:	Functional Specification Transfer Station for Garbage			
office: The Hague	Order: 33202	document: 3381001	rev.: A	sheet: 21	of: 23

### 7.3 Receptacles

The type and number of receptacles shall be assessed in cooperation with the Port Authority and the waste collection company, if applicable.

Figure 7.6, Figure 7.7 and Figure 7.8 show a number of possible receptacles.

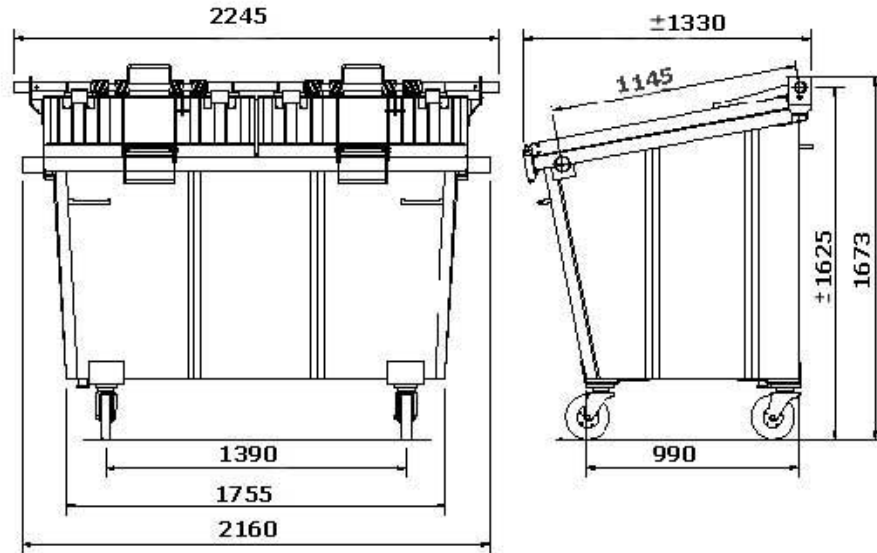

Figure 7.6: 2.5 m<sup>3</sup> container

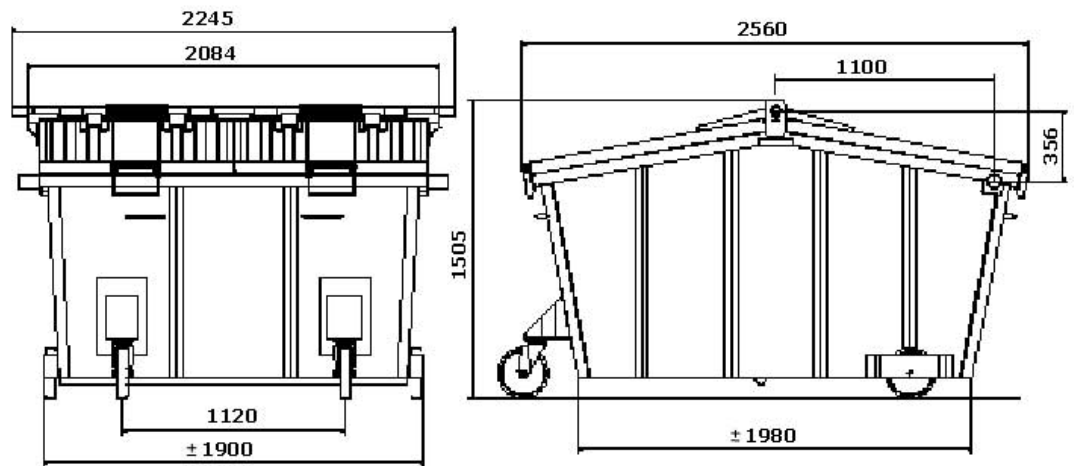

Figure 7.7: 5 m<sup>3</sup> container



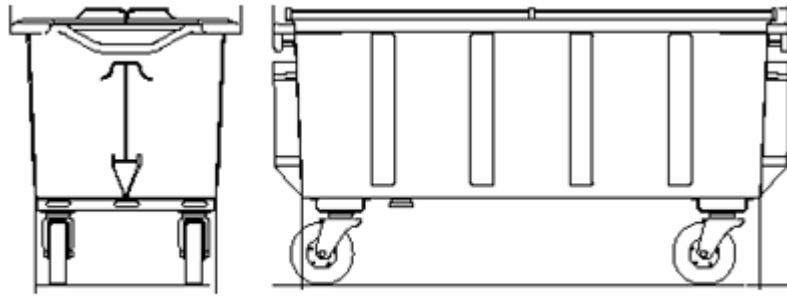
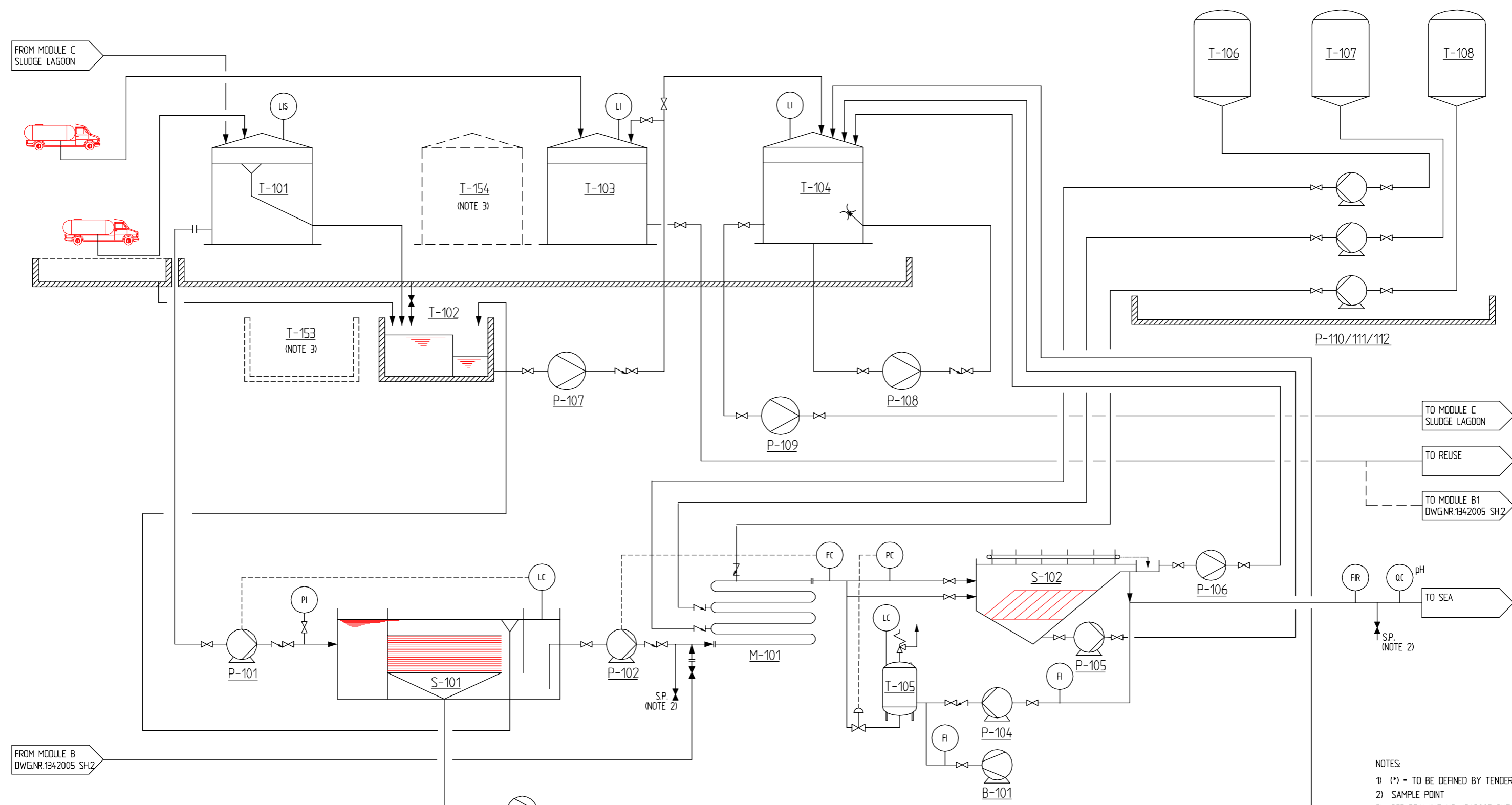

Figure 7.8: 0.5 – 1.6 m<sup>3</sup> container

## **Appendix C: Technical drawings for Oily waste treatment in Port reception facilities**

1. process Flow Diagram Oily Waste Treatment, Module A I; Drawing No. 1342005, Sheet 1 of 2, rev. 0;
2. process Flow Diagram Oily Waste Treatment, Module B I; Drawing No. 1342005, Sheet 2 of 2, rev. 0;
3. process Flow Diagram Oily Waste Treatment, Module A II; Drawing No. 1342006, Sheet 1 of 2, rev. 0;
4. process Flow Diagram Oily Waste Treatment, Module B II; Drawing No. 1342006, Sheet 2 of 2, rev. 0;
5. process Flow Diagram Oily Waste Treatment, Module A III; Drawing No. 1342007, Sheet 1 of 2, rev. 0;
6. process Flow Diagram Oily Waste Treatment, Module B III; Drawing No. 1342007, Sheet 2 of 2, rev. 0;
7. typical lay-out and section, Plot Plan, Oily Waste Treatment, Module A I/B I; Drawing No. 1342010, Sheet 1 of 1, rev. 0;
8. typical lay-out and section, Plot Plan, Oily Waste Treatment, Module A III/B III; Drawing No. 1342011, Sheet 1 of 1, rev. 0.
9. Legend sheet; Drawing No 134200, sheet 1 of 1, rev. 0.

<b>T-101</b> RECEPTION	<b>S-101</b> CORRUGATED PLATE SEPARATOR	<b>T-102</b> SLOP OIL COLLECTION TANK	<b>T-103</b> SLOP OIL TANK	<b>M-101</b> PIPE FLOCCULATOR	<b>S-102</b> DISSOLVED AIR FLOTATION	<b>T-104</b> SLUDGE BUFFER TANK	<b>T-105</b> AIR SATURATION TANK	<b>T-106</b> CHEM. DOSAGE TANK FeCl <sub>3</sub>	<b>T-107</b> CHEM. DOSAGE TANK Na(OH)	<b>T-108</b> CHEM. DOSAGE TANK FLOCCULANT AID
DIAMETER 4.6 m HEIGHT (cyl.) 6.0 m VOLUME 100 m <sup>3</sup>	CAPACITY 10 m <sup>3</sup> /h	LENGTH/WIDTH 3.0 m DEPTH 2.5 m VOLUME 20 m <sup>3</sup>	DIAMETER 3.6 m HEIGHT (cyl.) 5.0 m VOLUME 50 m <sup>3</sup>	CAPACITY 10 m <sup>3</sup> /h	CAPACITY 10 m <sup>3</sup> /h	DIAMETER 3.6 m HEIGHT (cyl.) 5.0 m VOLUME 50 m <sup>3</sup>	CAPACITY 20..100 % CAPACITY 2..10 m <sup>3</sup> /h	VOLUME NOTE 1 (*) m <sup>3</sup>	VOLUME NOTE 1 (*) m <sup>3</sup>	VOLUME NOTE 1 (*) m <sup>3</sup>



- NOTES:
- (\*) = TO BE DEFINED BY TENDERER
  - SAMPLE POINT
  - SEE DRAWING NO. 1342005 SHT.2

<b>P-101</b> C P S FEED PUMP	<b>P-102</b> D A F FEED PUMP	<b>P-103</b> SLUDGE TRANSFER PUMP	<b>P-104</b> RECYCLE PUMP	<b>P-105</b> SLUDGE TRANSFER PUMP	<b>P-106</b> SCUM TRANSFER PUMP	<b>P-107</b> SLOP OIL TRANSFER PUMP	<b>P-108</b> SLUDGE RECYCLE PUMP	<b>P-109</b> SLUDGE DRAIN OFF PUMP	<b>P-110</b> DOSING PUMP	<b>P-111</b> DOSING PUMP	<b>P-112</b> DOSING PUMP
CAPACITY 10 m <sup>3</sup> /h	CAPACITY 10 m <sup>3</sup> /h	CAPACITY NOTE 1 (*) m <sup>3</sup> /h	CAPACITY NOTE 1 (*) m <sup>3</sup> /h	CAPACITY NOTE 1 (*) m <sup>3</sup> /h	CAPACITY NOTE 1 (*) m <sup>3</sup> /h	CAPACITY NOTE 1 (*) m <sup>3</sup> /h	CAPACITY NOTE 1 (*) m <sup>3</sup> /h	CAPACITY NOTE 1 (*) m <sup>3</sup> /h	CAPACITY NOTE 1 (*) l/h	CAPACITY NOTE 1 (*) l/h	CAPACITY NOTE 1 (*) l/h

Rev	Date	Description	Drawn by	Chk	Seen by
A	08-10-04	Rempec Comments			JBRR
0	24-08-04	Comments			VWJK
Client: REMPEC					
Project: Port Reception Facilities					
			Title: Process Flow Diagram Oily Waste Treatment Module A I		
Branch/office	Dept	Scale	Size	Ordernumber	Sub
HENGLO	33	----	A-1	33202	00
				Drawnnumber	Sh
				1342005	1   2   A

**T-150**  
CENTRATE TANK  
(OILY WATER)  
LENGTH/WIDTH 2.0 m  
DEPTH 2.5 m  
VOLUME 10 m<sup>3</sup>

**T-151**  
CHEM. DOSAGE TANK  
FLOCCULANT AID  
VOLUME NOTE 1  
(\* ) m<sup>3</sup>

**S-150**  
DECANTER  
CENTRIFUGE  
CAPACITY 1.5 m<sup>3</sup>/h

**T-152**  
PRODUCT TANK  
(OIL, WATER FREE)  
LENGTH/WIDTH 2.0 m  
DEPTH 2.5 m  
VOLUME 10 m<sup>3</sup>

**T-153**  
DRAIN  
TANK  
LENGTH/WIDTH 2.0 m  
DEPTH 2.5 m  
VOLUME 10 m<sup>3</sup>

**T-154**  
WASTE OIL  
TANK  
DIAMETER 3.6 m  
HEIGHT (CYL.) 5.0 m  
VOLUME 50 m<sup>3</sup>

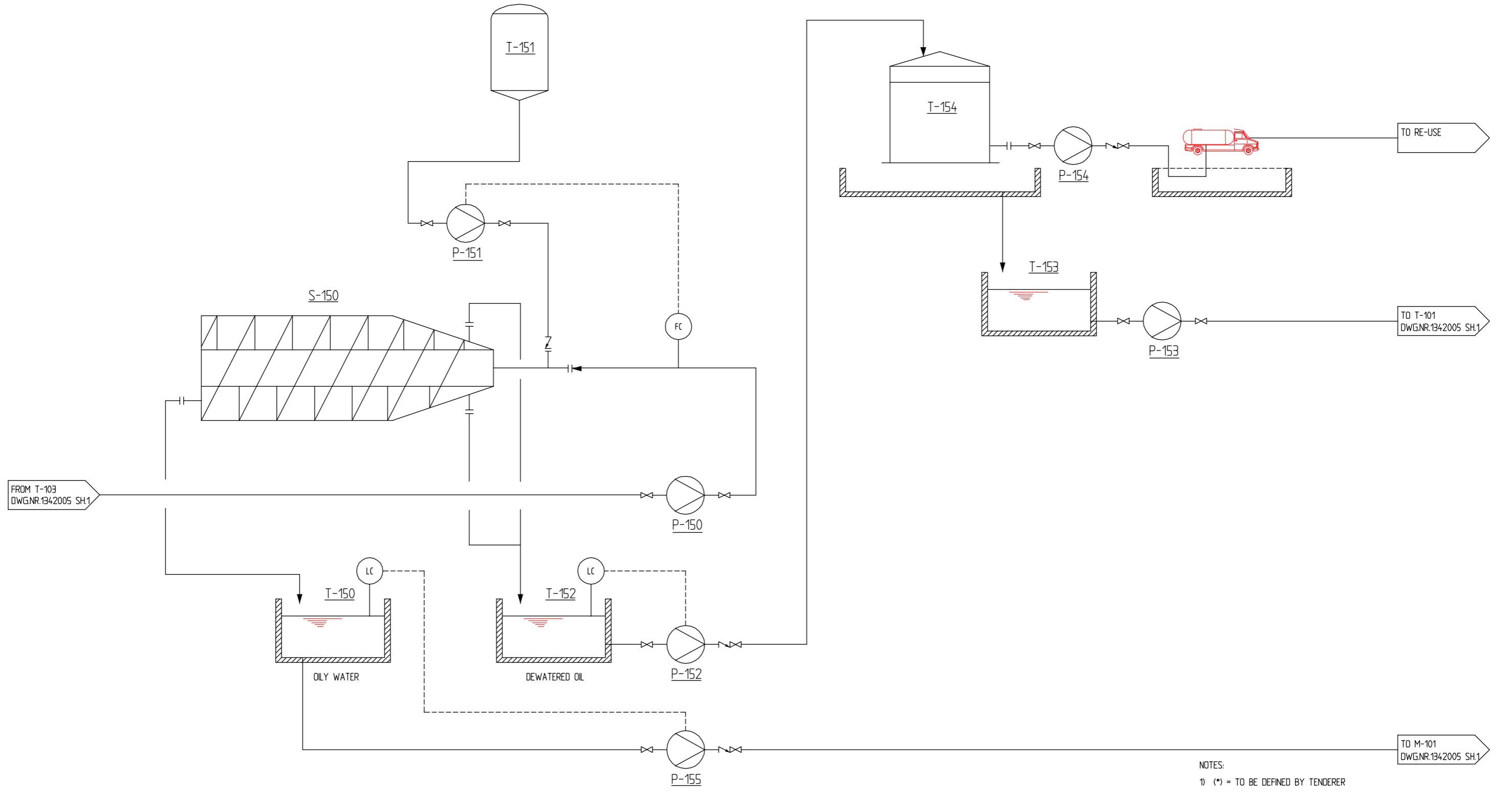

**P-150**  
DECANTER  
FEED PUMP  
CAPACITY 1.5 m<sup>3</sup>/h

**P-151**  
DOSING  
PUMP  
CAPACITY NOTE 1  
(\* ) l/h

**P-152**  
WASTE OIL  
TRANSFER PUMP  
CAPACITY 10 m<sup>3</sup>/h

**P-153**  
EMERGENCY  
PUMP  
CAPACITY 10 m<sup>3</sup>/h

**P-154**  
TRUCK LOADING  
PUMP  
CAPACITY 5 m<sup>3</sup>/h

**P-155**  
OILY WATER RETURN  
PUMP  
CAPACITY 5 m<sup>3</sup>/h

NOTES:  
1) (\*) = TO BE DEFINED BY TENDERER

Rev	Date	Description	Drawn by	Chk	Seen by
A	08-10-04	Rempec Comments			JBRR
0	24-08-04	Comments			VWJK
Client: REMPEC					
Project: Port Reception Facilities					
		Title: Process Flow Diagram Oily Waste Treatment Module B I			
		Branch office: HENGLO	Dept: 33	Scale: ----	Size: A-1
					Sh: 2   2   A



<b>T-201</b> RECEPTION DIAMETER 5.6 m HEIGHT (cyl.) 6.0 m VOLUME 150 m <sup>3</sup>	<b>S-201</b> CORRUGATED PLATE SEPARATOR CAPACITY 20 m <sup>3</sup> /h	<b>T-202</b> SLOP OIL COLLECTION TANK LENGTH/WIDTH 3.0 m DEPTH 2.5 m VOLUME 20 m <sup>3</sup>	<b>T-203</b> SLOP OIL TANK DIAMETER 4.6 m HEIGHT (cyl.) 6.0 m VOLUME 100 m <sup>3</sup>	<b>M-201</b> PIPE FLOCCULATOR CAPACITY 21 m <sup>3</sup> /h	<b>S-202</b> DISSOLVED AIR FLOTATION CAPACITY 21 m <sup>3</sup> /h	<b>T-204</b> SLUDGE BUFFER TANK DIAMETER 4.6 m HEIGHT (cyl.) 6.0 m VOLUME 100 m <sup>3</sup>	<b>T-205</b> AIR SATURATION TANK CAPACITY 20..100 % CAPACITY 4..21 m <sup>3</sup> /h	<b>T-206</b> CHEM. DOSAGE TANK FeCl <sub>3</sub> VOLUME NOTE 1 (*) m <sup>3</sup>	<b>T-207</b> CHEM. DOSAGE TANK Na(OH) VOLUME NOTE 1 (*) m <sup>3</sup>	<b>T-208</b> CHEM. DOSAGE TANK FLOCCULANT AID VOLUME NOTE 1 (*) m <sup>3</sup>
---	--	--	--	---	---	---	--	--	---	---

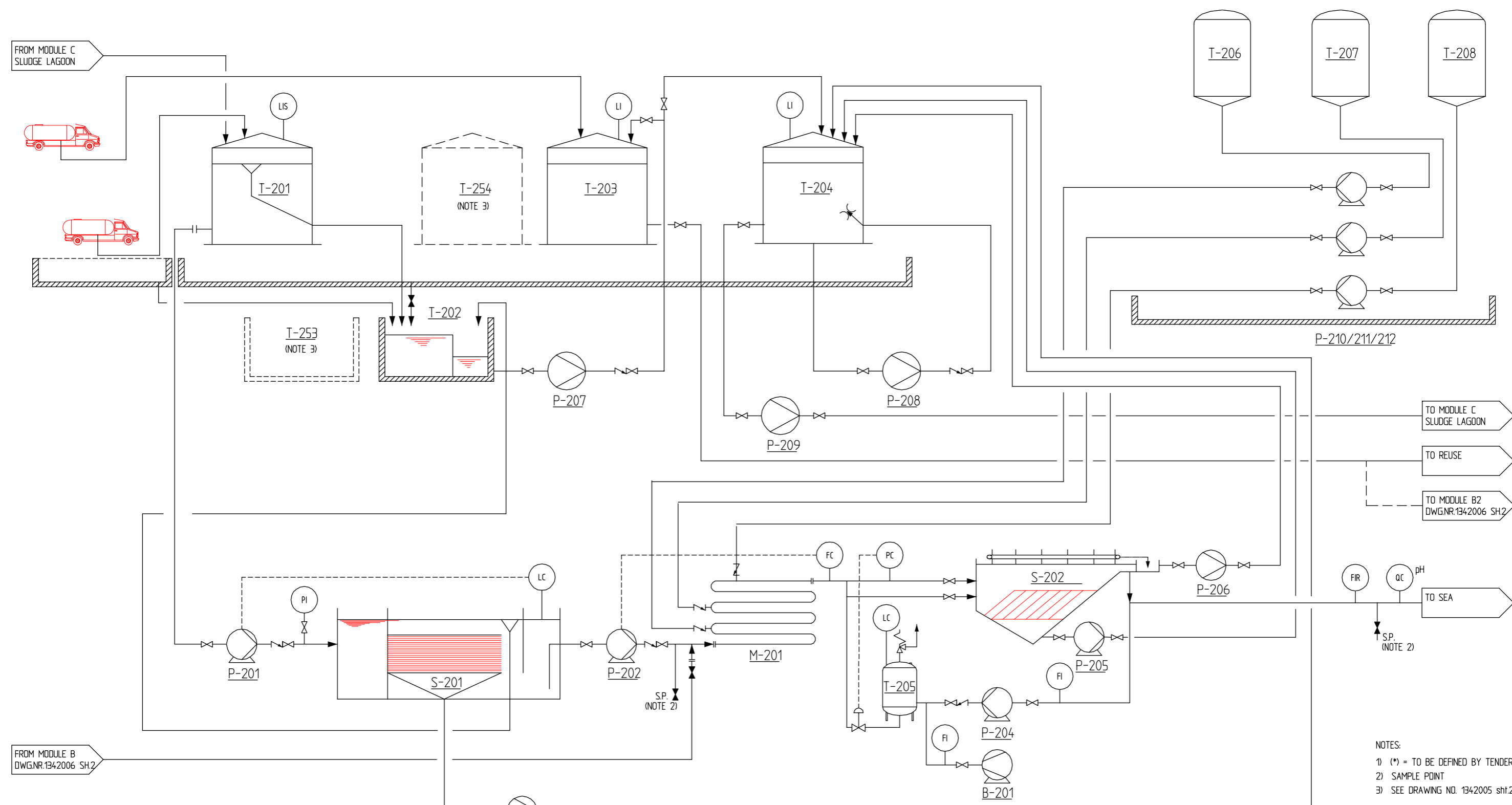

<b>P-201</b> C P S FEED PUMP CAPACITY 20 m <sup>3</sup> /h	<b>P-202</b> D A F FEED PUMP CAPACITY 20 m <sup>3</sup> /h	<b>P-203</b> SLUDGE TRANSFER PUMP CAPACITY NOTE 1 (*) m <sup>3</sup> /h	<b>P-204</b> RECYCLE PUMP CAPACITY NOTE 1 (*) m <sup>3</sup> /h	<b>P-205</b> SLUDGE TRANSFER PUMP CAPACITY NOTE 1 (*) m <sup>3</sup> /h	<b>P-206</b> SCUM TRANSFER PUMP CAPACITY NOTE 1 (*) m <sup>3</sup> /h	<b>P-207</b> SLOP OIL TRANSFER PUMP CAPACITY NOTE 1 (*) m <sup>3</sup> /h	<b>P-208</b> SLUDGE RECYCLE PUMP CAPACITY NOTE 1 (*) m <sup>3</sup> /h	<b>P-209</b> SLUDGE DRAIN OFF PUMP CAPACITY NOTE 1 (*) m <sup>3</sup> /h	<b>P-210</b> DOSING PUMP CAPACITY NOTE 1 (*) l/h	<b>P-211</b> DOSING PUMP CAPACITY NOTE 1 (*) l/h	<b>P-212</b> DOSING PUMP CAPACITY NOTE 1 (*) l/h
---	---	--	--	--	--	--	---	---	---	---	---

- NOTES:
- (\*) = TO BE DEFINED BY TENDERER
  - SAMPLE POINT
  - SEE DRAWING NO. 1342005 sh1.2

Rev	Date	Description	Drawn by	Chk	Seen by
0	08-10-04	Rempec Comments			JBRR
1	24-08-04	Comments			VWJK
Client: REMPEC					
Project: Port Reception Facilities					
			Title: Process Flow Diagram Oily Waste Treatment Module A2		
Branch/office	Dept	Scale	Size	Ordernumber	Sub
HENGLO	33	----	A-1	33202	00
Drawn	Drawn	Drawn	Drawn	Drawn	Drawn
1342006	1	2	A		

**T-250**  
CENTRATE TANK  
(OILY WATER)  
LENGTH/WIDTH 2.0 m  
DEPTH 2.5 m  
VOLUME 10 m<sup>3</sup>

**T-251**  
CHEM. DOSAGE TANK  
FLOCCULANT AID  
VOLUME (\*) m<sup>3</sup>

**S-250**  
DECANTER  
CENTRIFUGE  
CAPACITY 1.5 m<sup>3</sup>/h

**T-252**  
PRODUCT TANK  
(OIL, WATER FREE)  
LENGTH/WIDTH 2.0 m  
DEPTH 2.5 m  
VOLUME 10 m<sup>3</sup>

**T-253**  
DRAIN TANK  
LENGTH/WIDTH 2.0 m  
DEPTH 2.5 m  
VOLUME 10 m<sup>3</sup>

**T-254**  
WASTE OIL TANK  
DIAMETER 3.6 m  
HEIGHT (CYL.) 5.0 m  
VOLUME 50 m<sup>3</sup>

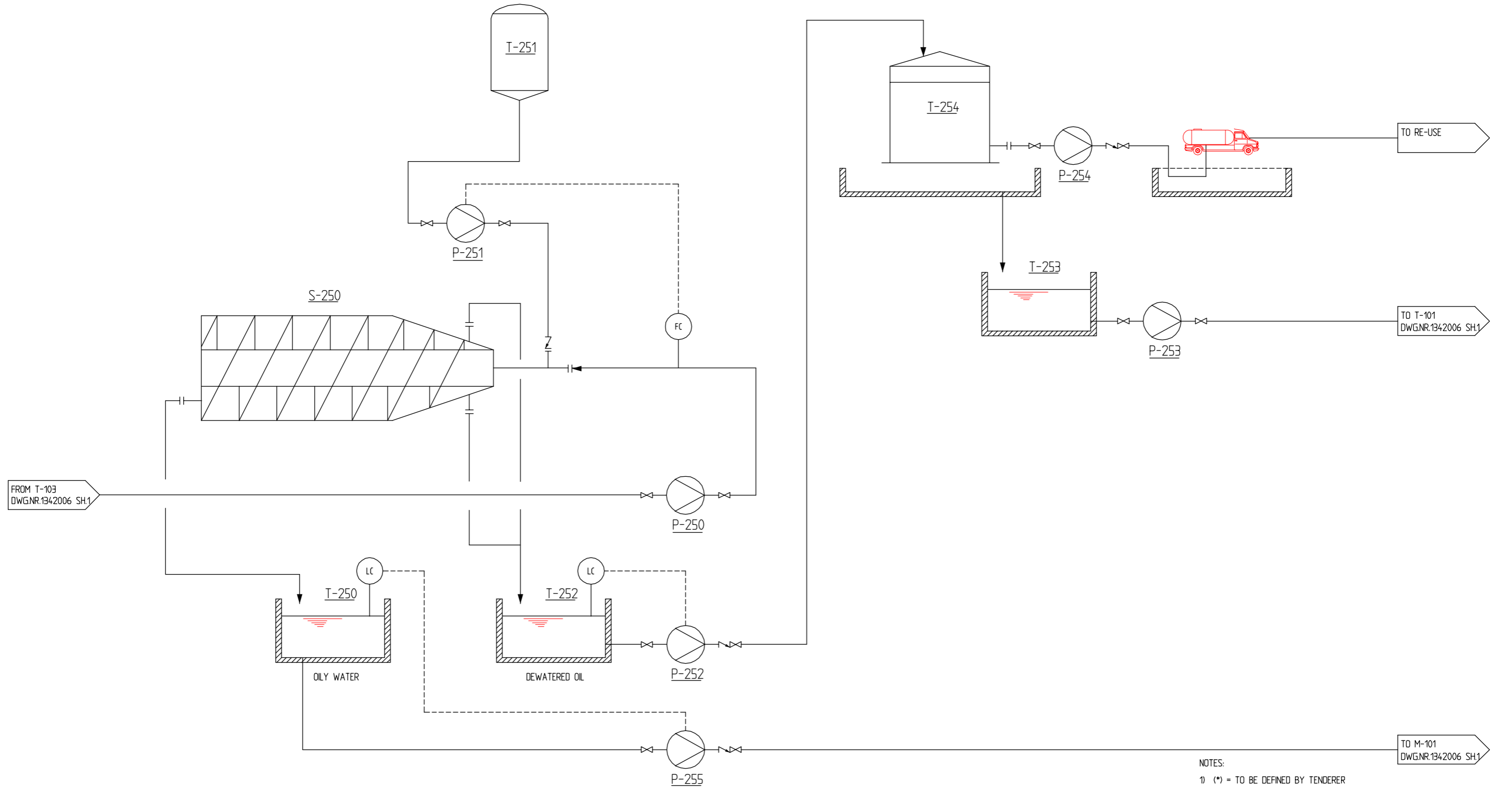

NOTES:  
1) (\*) = TO BE DEFINED BY TENDERER

**P-250**  
DECANTER  
FEED PUMP  
CAPACITY 1.5 m<sup>3</sup>/h

**P-251**  
DOSING  
PUMP  
CAPACITY (\*) L/h

**P-252**  
WASTE OIL  
TRANSFER PUMP  
CAPACITY 15 m<sup>3</sup>/h

**P-253**  
EMERGENCY  
PUMP  
CAPACITY 10 m<sup>3</sup>/h

**P-254**  
TRUCK LOADING  
PUMP  
CAPACITY 5 m<sup>3</sup>/h

**P-255**  
OILY WATER RETURN  
PUMP  
CAPACITY 5 m<sup>3</sup>/h

Rev	Date	Description	Drawn by	Chk	Seen by
A	08-10-04	Rempec Comments			JBRR
0	24-08-04	Comments			VWJK
Client: REMPEC					
Project: Port Reception Facilities					
 TEBODIN Consultants & Engineers		Title: Process Flow Diagram Oily Waste Treatment Module B II			
Branch/office	Dept	Scale	Size	Order number	Sub
HENGLO	33	----	A-1	33202	00
				Drawing number	Sh
				1342006	2   2   A

<b>T-301</b> RECEPTION	<b>S-301</b> CORRUGATED PLATE SEPARATOR	<b>T-302</b> SLOP OIL COLLECTION TANK	<b>T-303</b> SLOP OIL TANK	<b>M-301</b> PIPE FLOCCULATOR	<b>S-302</b> DISSOLVED AIR FLOTATION	<b>T-304</b> SLUDGE BUFFER TANK	<b>T-305</b> AIR SATURATION TANK	<b>T-306</b> CHEM. DOSAGE TANK FeCL <sub>3</sub>	<b>T-307</b> CHEM. DOSAGE TANK Na(OH)	<b>T-308</b> CHEM. DOSAGE TANK FLOCCULANT AID
DIAMETER 8.5 m HEIGHT (cyl.) 9.0 m VOLUME 500 m <sup>3</sup>	CAPACITY 50 m <sup>3</sup> /h	LENGTH/WIDTH 4.0 m DEPTH 2.5 m VOLUME 30 m <sup>3</sup>	DIAMETER 4.6 m HEIGHT (cyl.) 6.0 m VOLUME 100 m <sup>3</sup>	CAPACITY 55 m <sup>3</sup> /h	CAPACITY 55 m <sup>3</sup> /h	DIAMETER 5.8 m HEIGHT (cyl.) 7.5 m VOLUME 200 m <sup>3</sup>	CAPACITY 20..100 % CAPACITY 11.55 m <sup>3</sup> /h	VOLUME NOTE 1 (*) m <sup>3</sup>	VOLUME NOTE 1 (*) m <sup>3</sup>	VOLUME NOTE 1 (*) m <sup>3</sup>

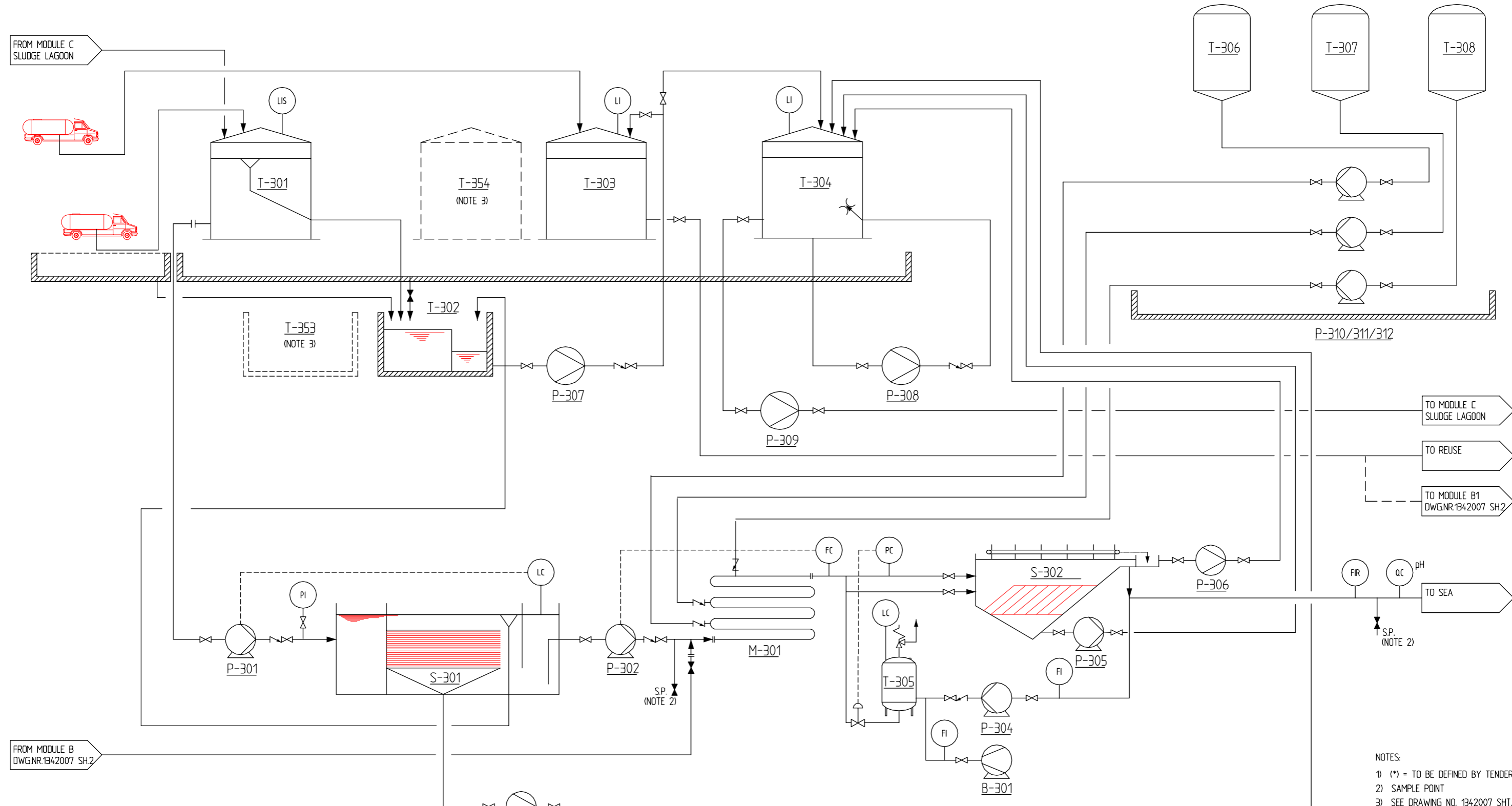

<b>P-301</b> C P S FEED PUMP	<b>P-302</b> D A F FEED PUMP	<b>P-303</b> SLUDGE TRANSFER PUMP	<b>P-304</b> RECYCLE PUMP	<b>P-305</b> SLUDGE TRANSFER PUMP	<b>P-306</b> SCUM TRANSFER PUMP	<b>P-307</b> SLOP OIL TRANSFER PUMP	<b>P-308</b> SLUDGE RECYCLE PUMP	<b>P-309</b> SLUDGE DRAIN OFF PUMP	<b>P-310</b> DOSING PUMP	<b>P-311</b> DOSING PUMP	<b>P-312</b> DOSING PUMP
CAPACITY 50 m <sup>3</sup> /h	CAPACITY 50 m <sup>3</sup> /h	CAPACITY NOTE 1 (*) m <sup>3</sup> /h	CAPACITY NOTE 1 (*) m <sup>3</sup> /h	CAPACITY NOTE 1 (*) m <sup>3</sup> /h	CAPACITY NOTE 1 (*) m <sup>3</sup> /h	CAPACITY NOTE 1 (*) m <sup>3</sup> /h	CAPACITY NOTE 1 (*) m <sup>3</sup> /h	CAPACITY NOTE 1 (*) l/h	CAPACITY NOTE 1 (*) l/h	CAPACITY NOTE 1 (*) m <sup>3</sup> /h	CAPACITY NOTE 1 (*) l/h

- NOTES:
- (\*) = TO BE DEFINED BY TENDERER
  - SAMPLE POINT
  - SEE DRAWING NO. 1342007 SHT.2

Rev	Date	Description	Drawn by	Chk	Seen by
A	08-10-04	Rempec Comments			JBRR
0	24-08-04	Comments			VWJK
Client: REMPEC					
Project: Port Reception Facilities					
			Title: Process Flow Diagram Oily Waste Treatment Module A3		
Branch office	Dept	Scale	Size	Order number	Sub
HENGLO	33	----	A-1	33202	00
			Drawn by	1342007	Sh 1 of 2

**T-350**  
CENTRATE TANK  
(OILY WATER)  
LENGTH/WIDTH 2.0 m  
DEPTH 2.5 m  
VOLUME 10 m<sup>3</sup>

**T-351**  
CHEM. DOSAGE TANK  
FLOCCULANT AID  
VOLUME NOTE 1 (\*) m<sup>3</sup>

**S-350**  
DECANTER  
CENTRIFUGE  
CAPACITY 1.5 m<sup>3</sup>/h

**T-352**  
PRODUCT TANK  
(OIL, WATER FREE)  
LENGTH/WIDTH 2.0 m  
DEPTH 2.5 m  
VOLUME 10 m<sup>3</sup>

**T-353**  
DRAIN TANK  
LENGTH/WIDTH 2.0 m  
DEPTH 2.5 m  
VOLUME 10 m<sup>3</sup>

**T-354**  
WASTE OIL TANK  
DIAMETER 3.6 m  
HEIGHT (CYL.) 5.0 m  
VOLUME 50 m<sup>3</sup>

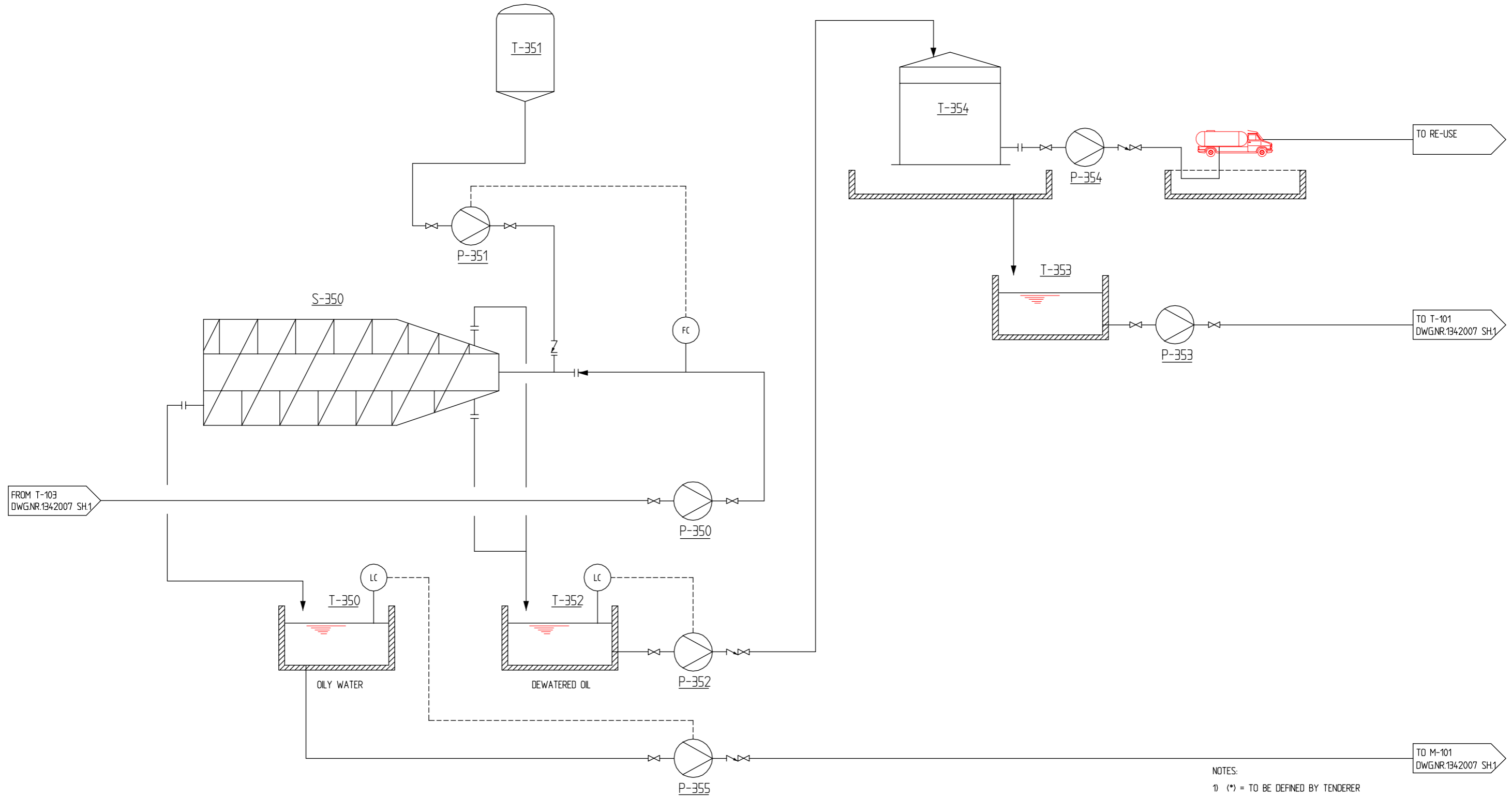

**P-350**  
DECANTER  
FEED PUMP  
CAPACITY 1.5 m<sup>3</sup>/h

**P-351**  
DOSING  
PUMP  
CAPACITY NOTE 1 (\*) l/h

**P-352**  
WASTE OIL  
TRANSFER PUMP  
CAPACITY 25 m<sup>3</sup>/h

**P-353**  
EMERGENCY  
PUMP  
CAPACITY 10 m<sup>3</sup>/h

**P-354**  
TRUCK LOADING  
PUMP  
CAPACITY 5 m<sup>3</sup>/h

**P-355**  
OILY WATER RETURN  
PUMP  
CAPACITY 5 m<sup>3</sup>/h

NOTES:  
1) (\*) = TO BE DEFINED BY TENDERER

Rev	Date	Description	Drawn by	Chk	Seen by
A	08-10-04	Rempec Comments			JBRR
0	24-08-04	Comments			VWJK
Client: REMPEC					
Project: Port Reception Facilities					
		Title: Process Flow Diagram Oily Waste Treatment Module B III			
Branch office	Dept	Scale	Size	Order number	Sub
HENGLO	33	----	A-1	33202	00
			Drawing number	Sh	of
			1342007	2	2
					Rev.
					A





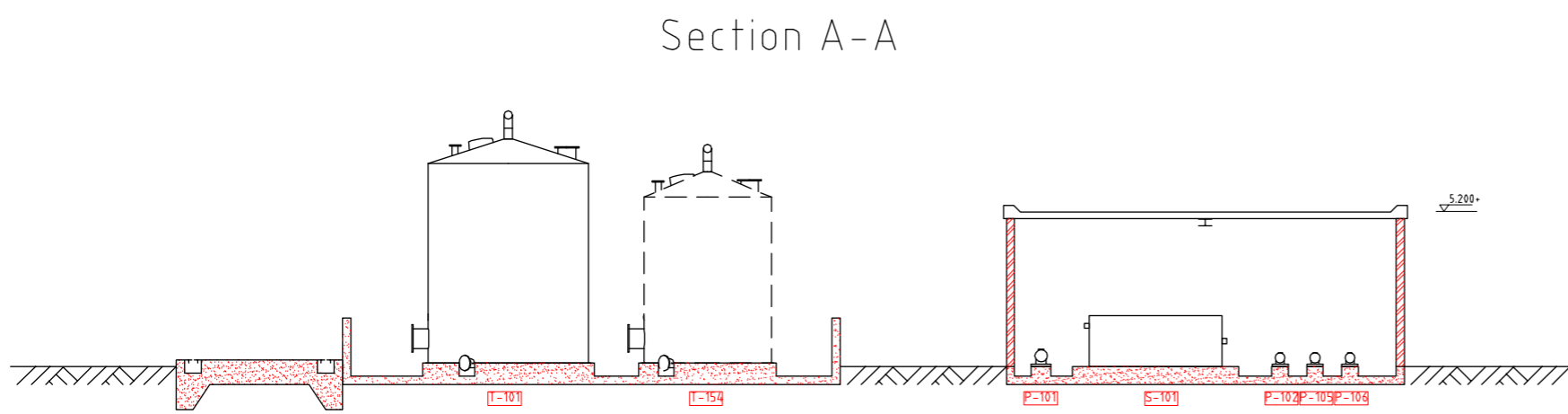
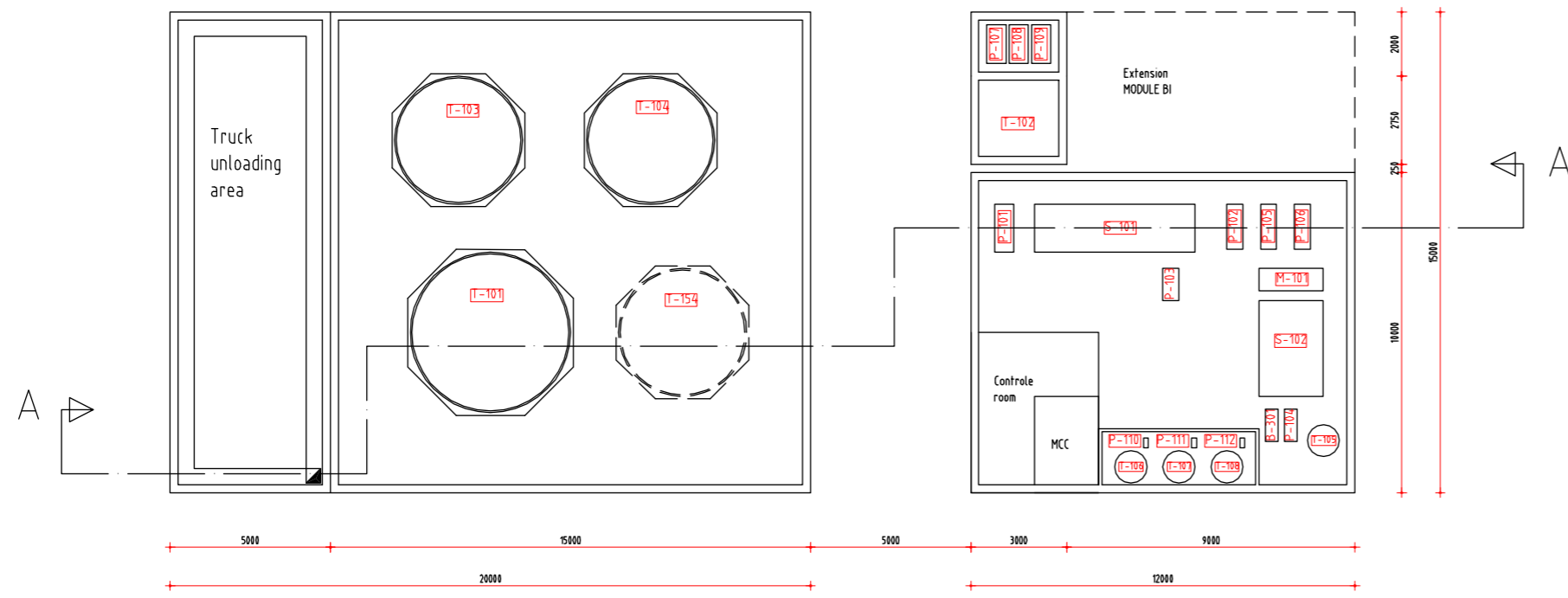

**GENERAL REMARKS**

- All dimensions in mm
- Elevations in meters related to 0.000
- Level mark = 0.000 = ... High point of asphalt paving
- On all visible concrete corners to be chamfered

Rev.	Date	Description	Drawn by	Okd	Seen by
A	08-10-'04	Rempec Comments			
0	23-08-'04	Comments			
Client: REMPEC					
Project: Port Reception Facilities					
		Title: Typical layout and section Plot Plan Oily Waste Treatment Modules AI / BI			
Branch office	Dept	Scale	Size	Order number	Sub
HENGLO	33	1:100	A-1	33202	00
				Drawn number	Sh
				1342010	1
				of	1
				Rev.	A

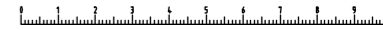

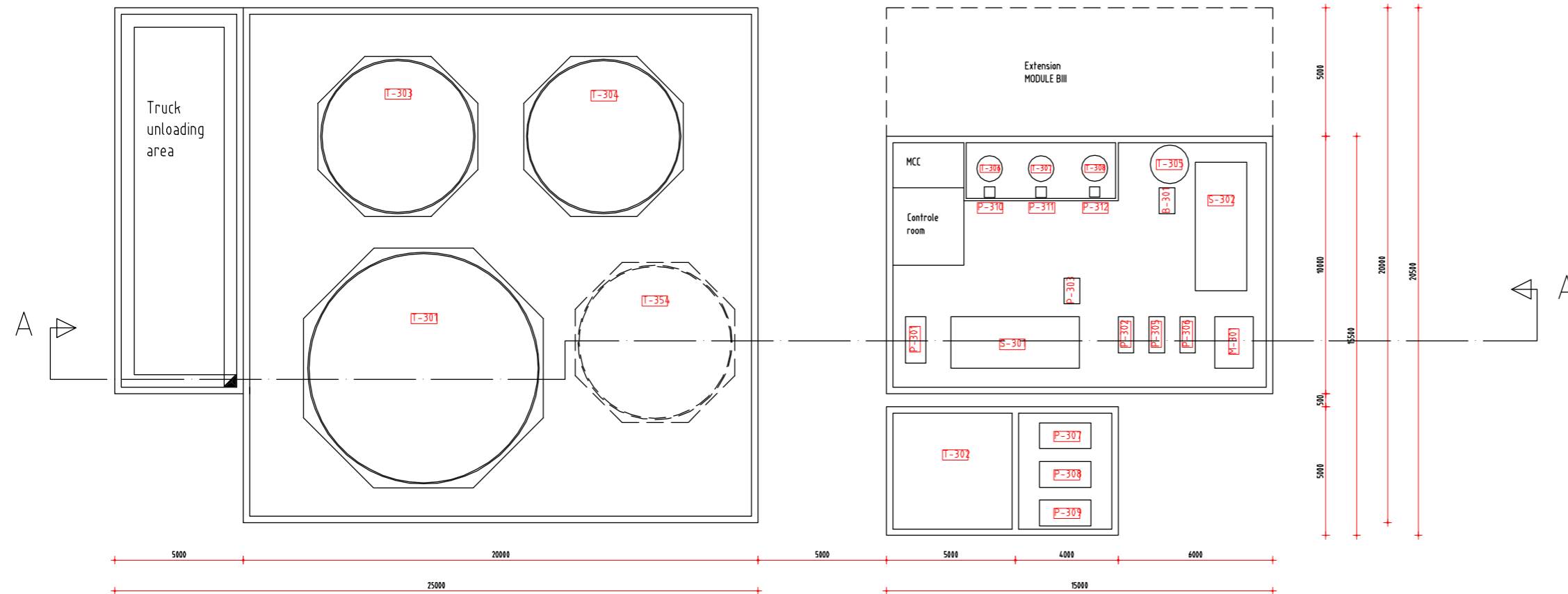

**GENERAL REMARKS**

- All dimensions in mm
- Elevations in meters related to 0.000
- Level mark = 0.000 = ... High point of asphalt paving
- On all visible concrete corners to be chamfered

Section A-A

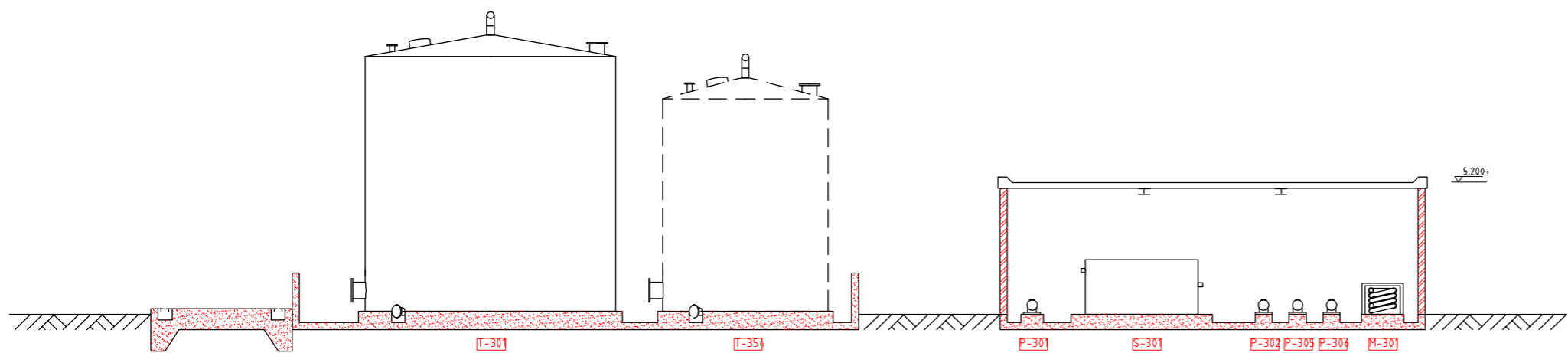

Rev	Date	Description	Drawn by	Okd	Seen by
A	08-10-'04	Rempec Comments			
0	23-08-'04	Comments			
Client			REMPEC		
Project			Port Reception Facilities		
		Title Typical layout and section Plot Plan Oily Waste Treatment Modules AIII / BIII			
Branch office	Dept	Scale	Size	Order number	Sub
HENGLO	33	1:100	A-1	33202	00
Drawn by	Drawn number	Sh	of	Rev.	
	1342011	1	1	A	

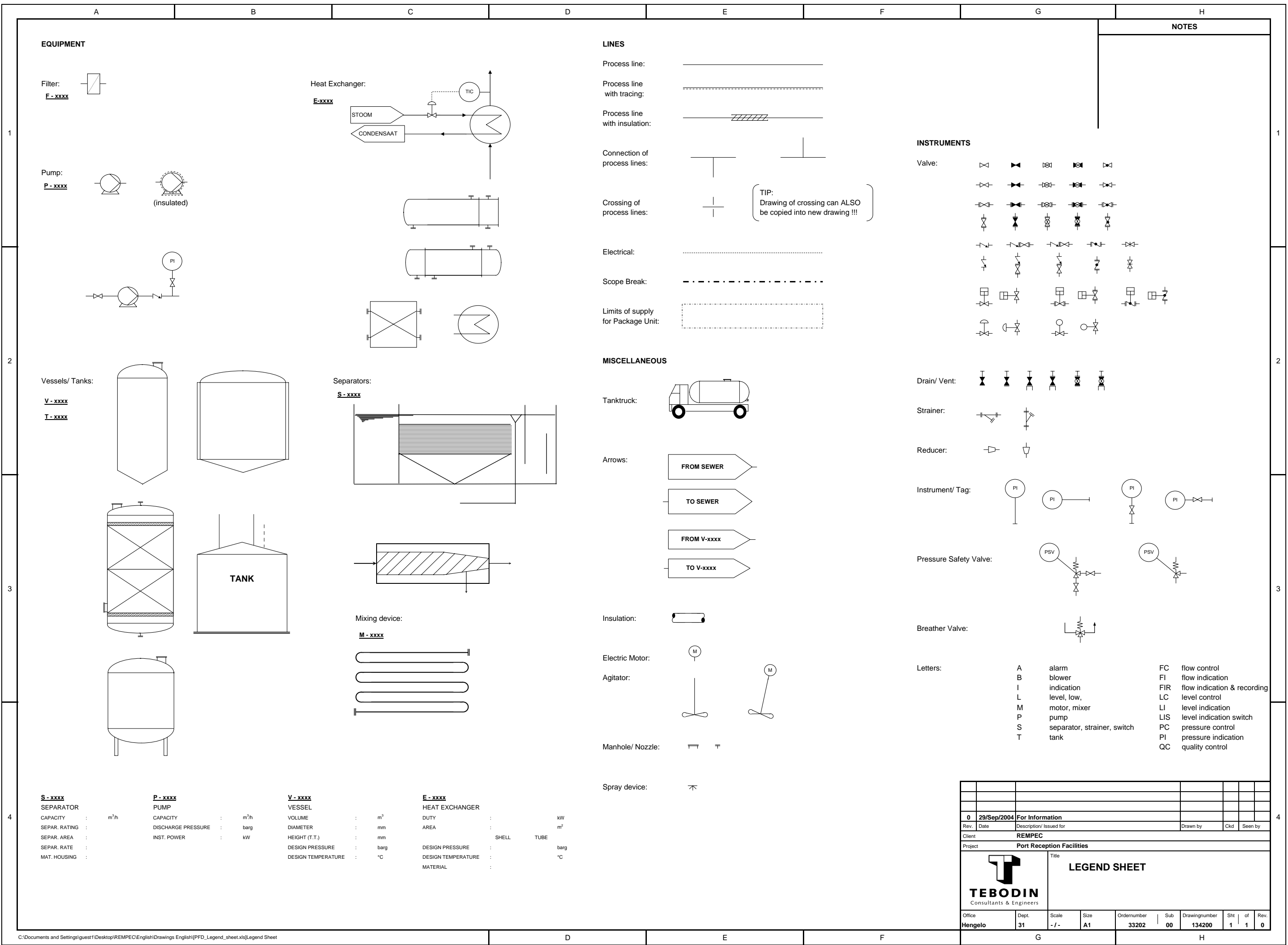

**EQUIPMENT**

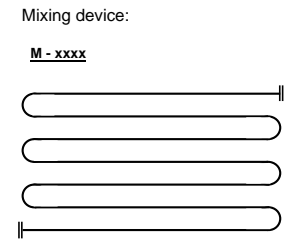
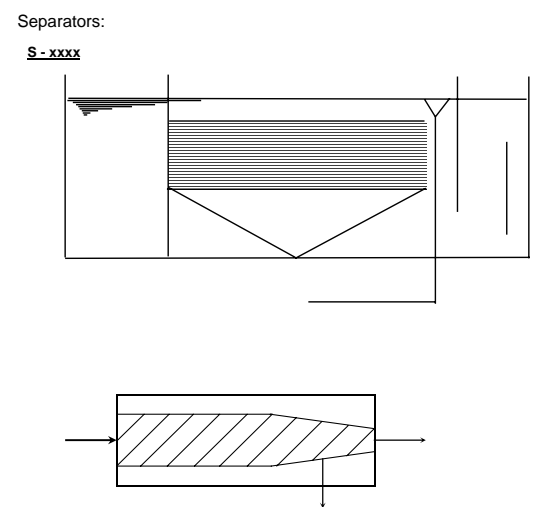
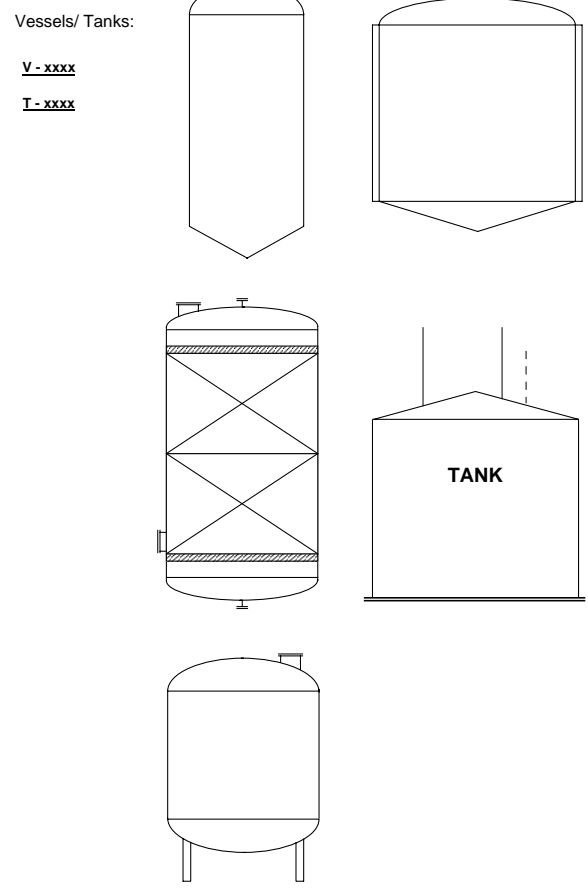
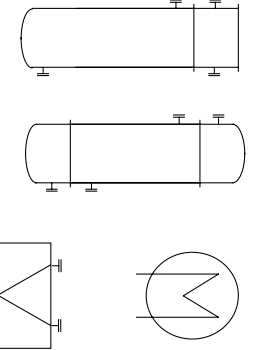
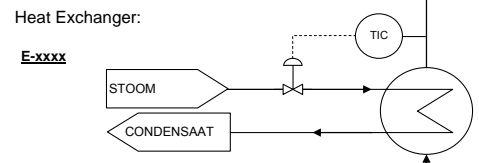
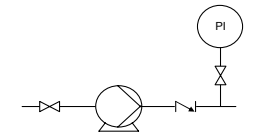
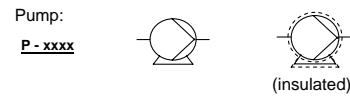
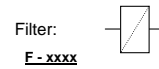

**LINES**

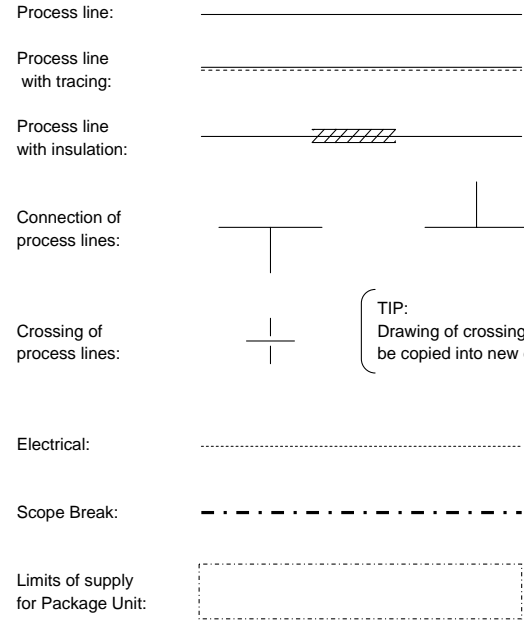

TIP:  
Drawing of crossing can ALSO  
be copied into new drawing !!!

**MISCELLANEOUS**

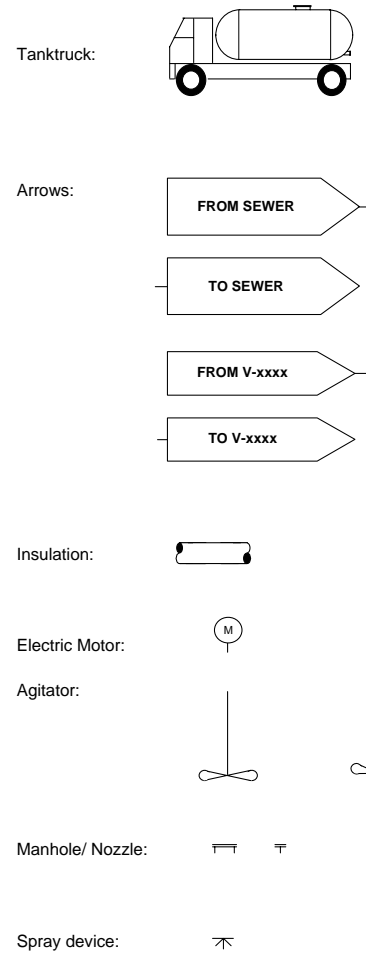

**INSTRUMENTS**

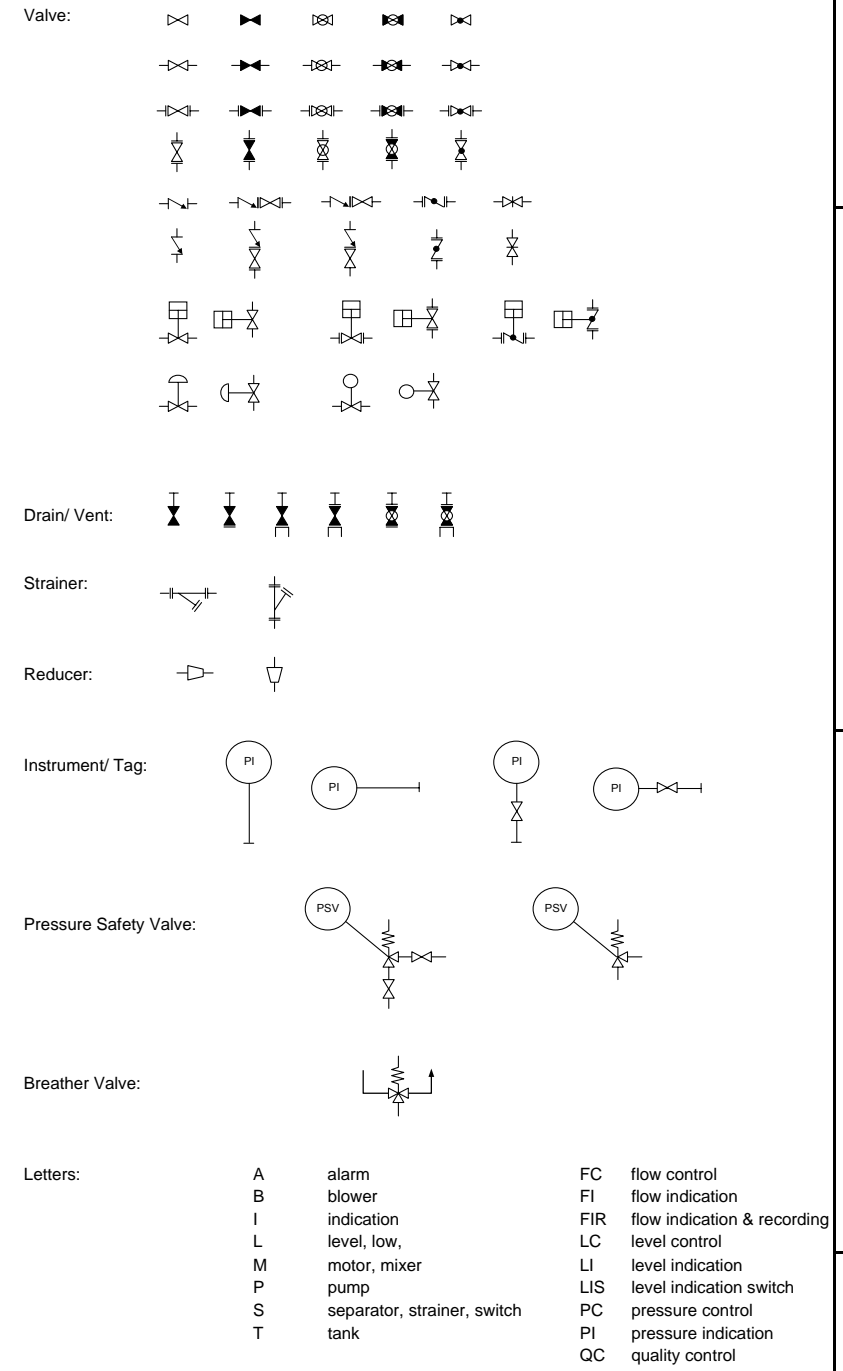

<b>S - xxxx</b> SEPARATOR	<b>P - xxxx</b> PUMP	<b>V - xxxx</b> VESSEL	<b>E - xxxx</b> HEAT EXCHANGER
CAPACITY : m <sup>3</sup> /h	CAPACITY : m <sup>3</sup> /h	VOLUME : m <sup>3</sup>	DUTY : kW
SEPAR. RATING : barg	DISCHARGE PRESSURE : barg	DIAMETER : mm	AREA : m <sup>2</sup>
SEPAR. AREA : m <sup>2</sup>	INST. POWER : kW	HEIGHT (T.T.) : mm	DESIGN PRESSURE : barg
SEPAR. RATE : m <sup>3</sup> /h		DESIGN PRESSURE : barg	DESIGN PRESSURE : barg
MAT. HOUSING : mm		DESIGN TEMPERATURE : °C	DESIGN TEMPERATURE : °C
		MATERIAL : mm	

0		29/Sep/2004		For Information					
Rev.	Date	Description/ Issued for				Drawn by	Ckd	Seen by	
Client: REMPEC									
Project: Port Reception Facilities									
 <b>TEBODIN</b> Consultants & Engineers					<b>LEGEND SHEET</b>				
Office	Dept.	Scale	Size	Ordernumber	Sub	Drawingnumber	Stt	of	Rev.
Hengelo	31	- / -	A1	33202	00	134200	1	1	0

## **Appendix D: Technical drawings for Transfer Stations of Garbage**

1. drawing No.33002050, Sheet 1 of 1, Typical layout and section Garbage Transfer Station for quantities < 1000 m<sup>3</sup>/Year;
2. drawing No.33002051, Sheet 1 of 1, Typical layout and section Garbage Transfer Station for quantities 1000 - 2000 m<sup>3</sup>/Year;
3. drawing No.33002052, Sheet 1 of 1, Typical layout and section Garbage Transfer Station for quantities > 2000 m<sup>3</sup>/Year.

GENERAL REMARKS

- All dimensions in mm
- Elevations in meters related to 0.000
- Level mark = 0.000 = ... High point of asphalt paving
- On all visible concrete corners to be chamfered

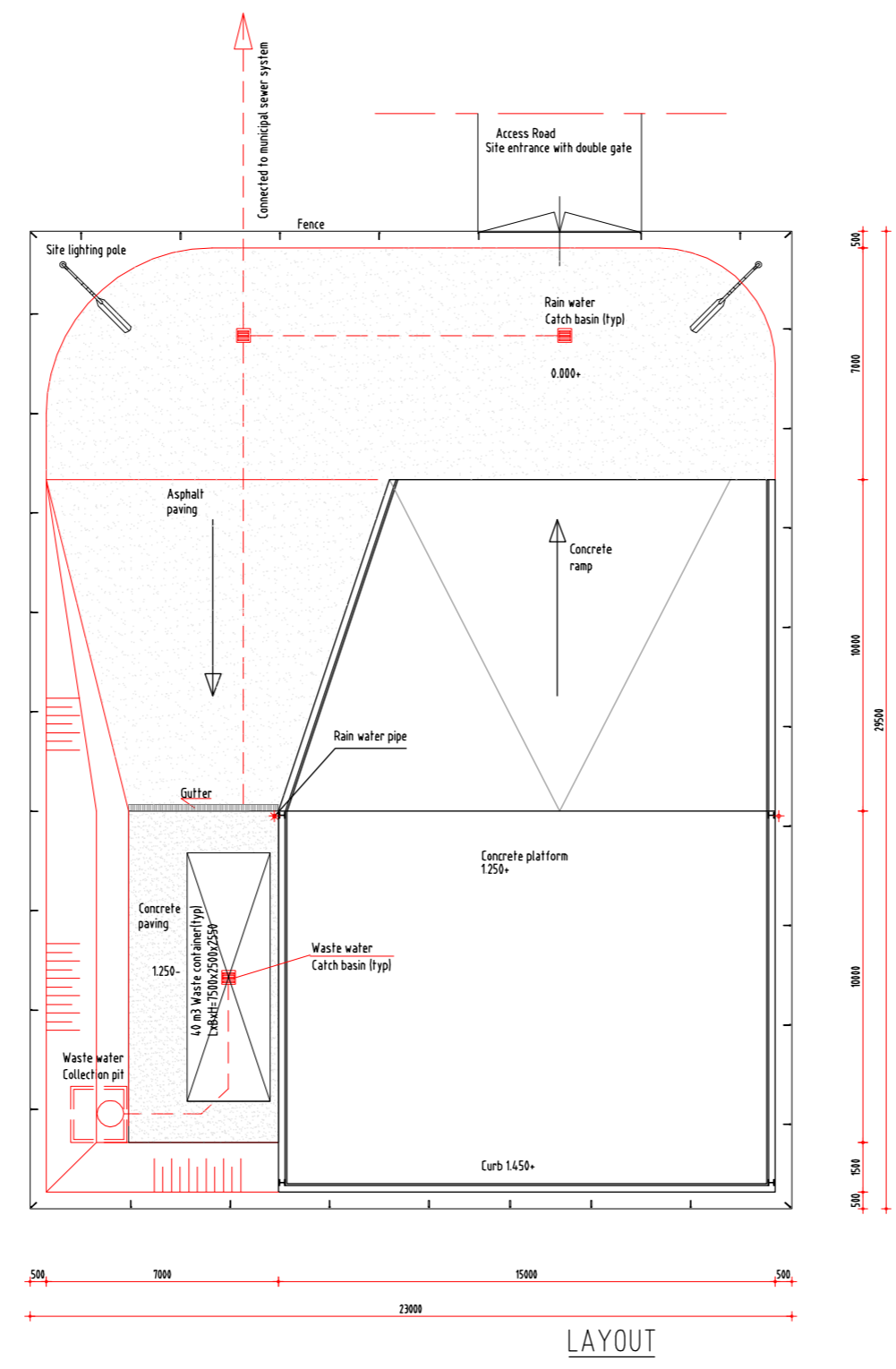
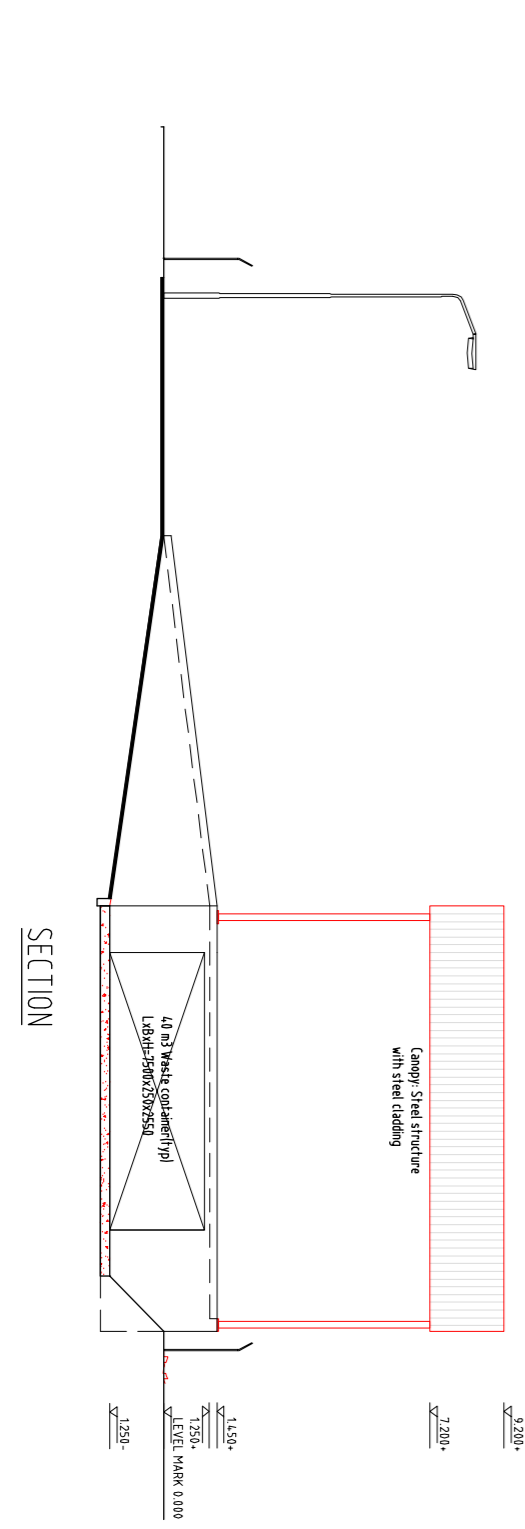

A	08-10-'04	Rempec Comments		JBRR		
0	12-08-'04	Comments		DEB	H.H	
Rev.	Date	Description		Drawn by	Okd	Seen by

Client: REMPEC  
 Project: Port Reception Facilities

Title: Typical layout and section Garbage Transfer Station For quantities < 1000 m<sup>3</sup>/Year

Branch office: THE HAGUE	Dept: 11	Scale: 1:100	Size: A-1	Order number: 33202	Sub: 00	Drawing number: 33002050	Sheet: 1 of 1	Rev: A
--------------------------	----------	--------------	-----------	---------------------	---------	--------------------------	---------------	--------

GENERAL REMARKS

- All dimensions in mm
- Elevations in meters related to 0.000
- Level mark = 0.000 = ... High point of asphalt paving
- On all visible concrete corners to be chamfered

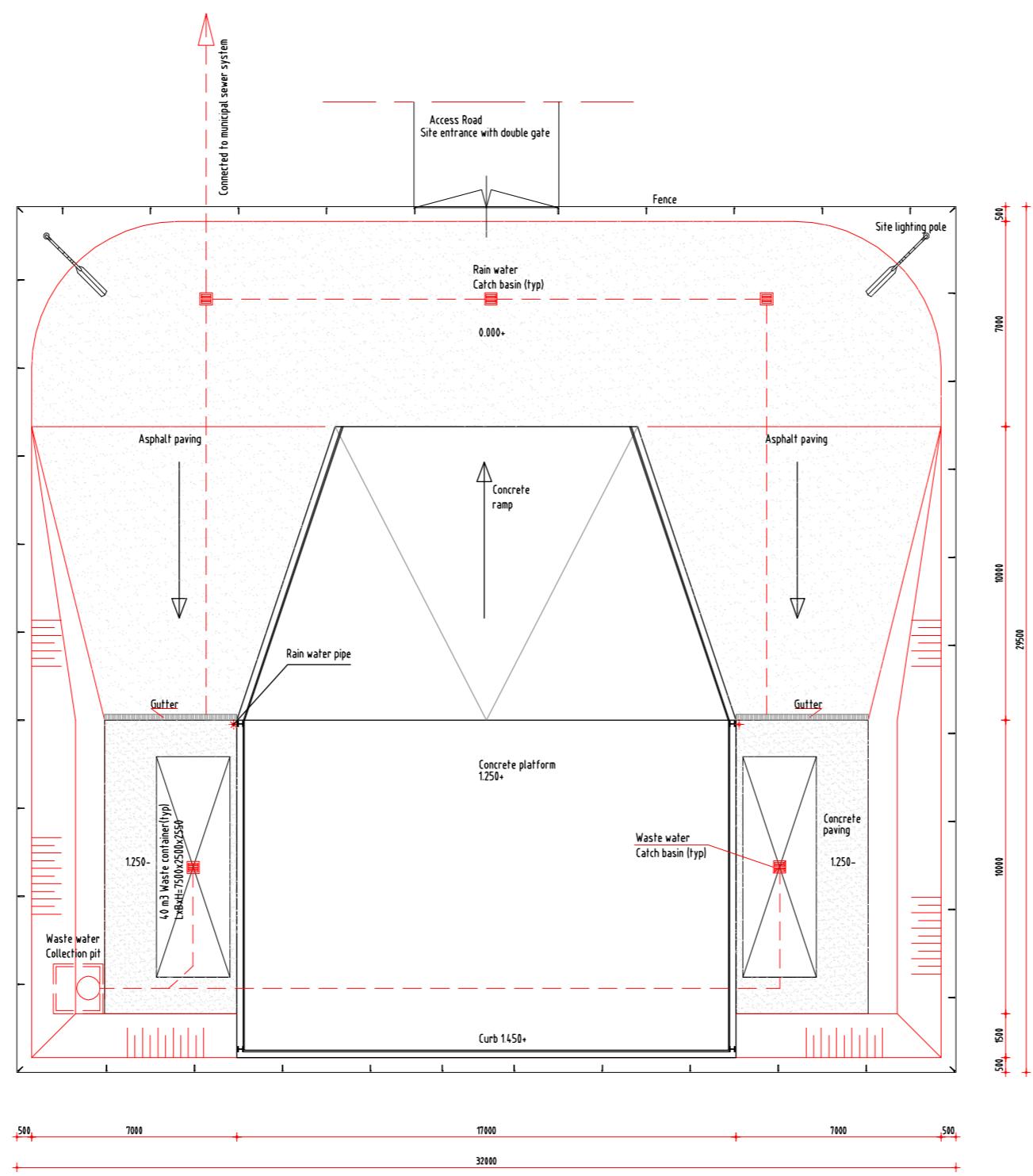

500  
7000  
10000  
26500  
10000  
500

500 7000 17000 7000 500  
32000

LAYOUT

SECTION

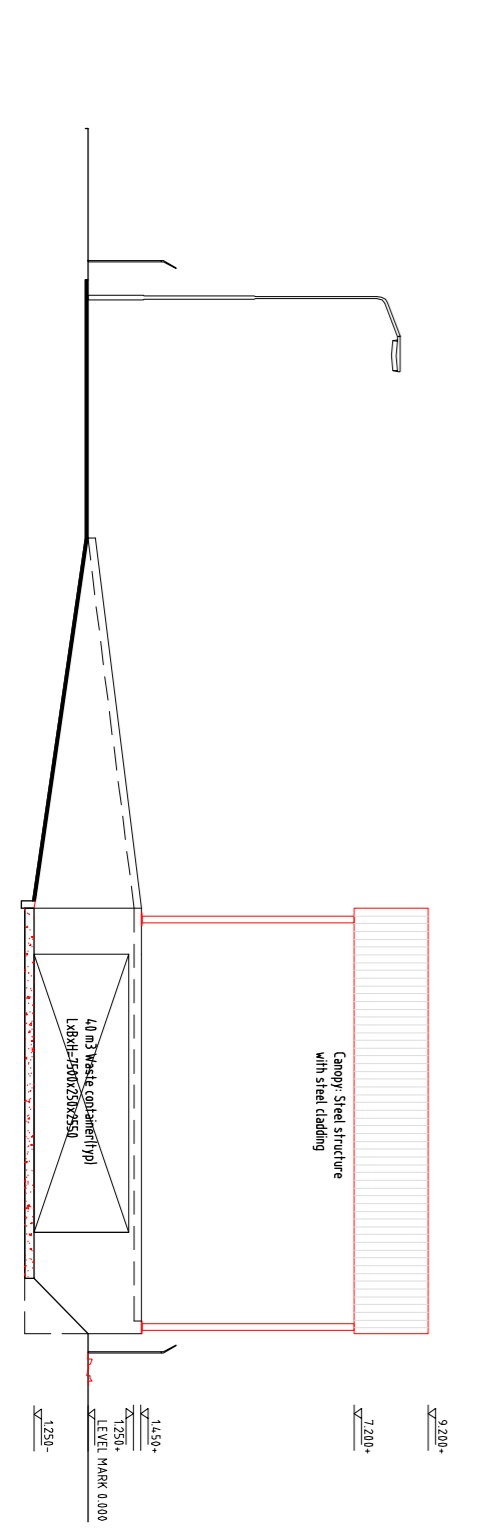

1.250-  
1.450-  
1.750-  
LEVEL MARK 0.000  
7.200-  
9.200-

A	08-10-'04	Rempec Comments	JBRR		
0	12-08-'04	Comments	DEB	H.H	
Rev.	Date	Description	Drawn by	Okd	Seen by

Client: REMPEC  
Project: Port Reception Facilities

**TEBODIN**  
Consultants & Engineers

Title: Typical layout and section  
Garbage Transfer Station  
For quantities of 1000-2000 m3/Year

Branch office: THE HAGUE	Dept: 11	Scale: 1:100	Site: A-1	Order number: 33202	Sub: 00	Drawing number: 33002051	Sh: 1	Of: 1	Rev: A
--------------------------	----------	--------------	-----------	---------------------	---------	--------------------------	-------	-------	--------

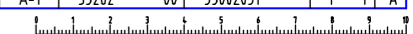

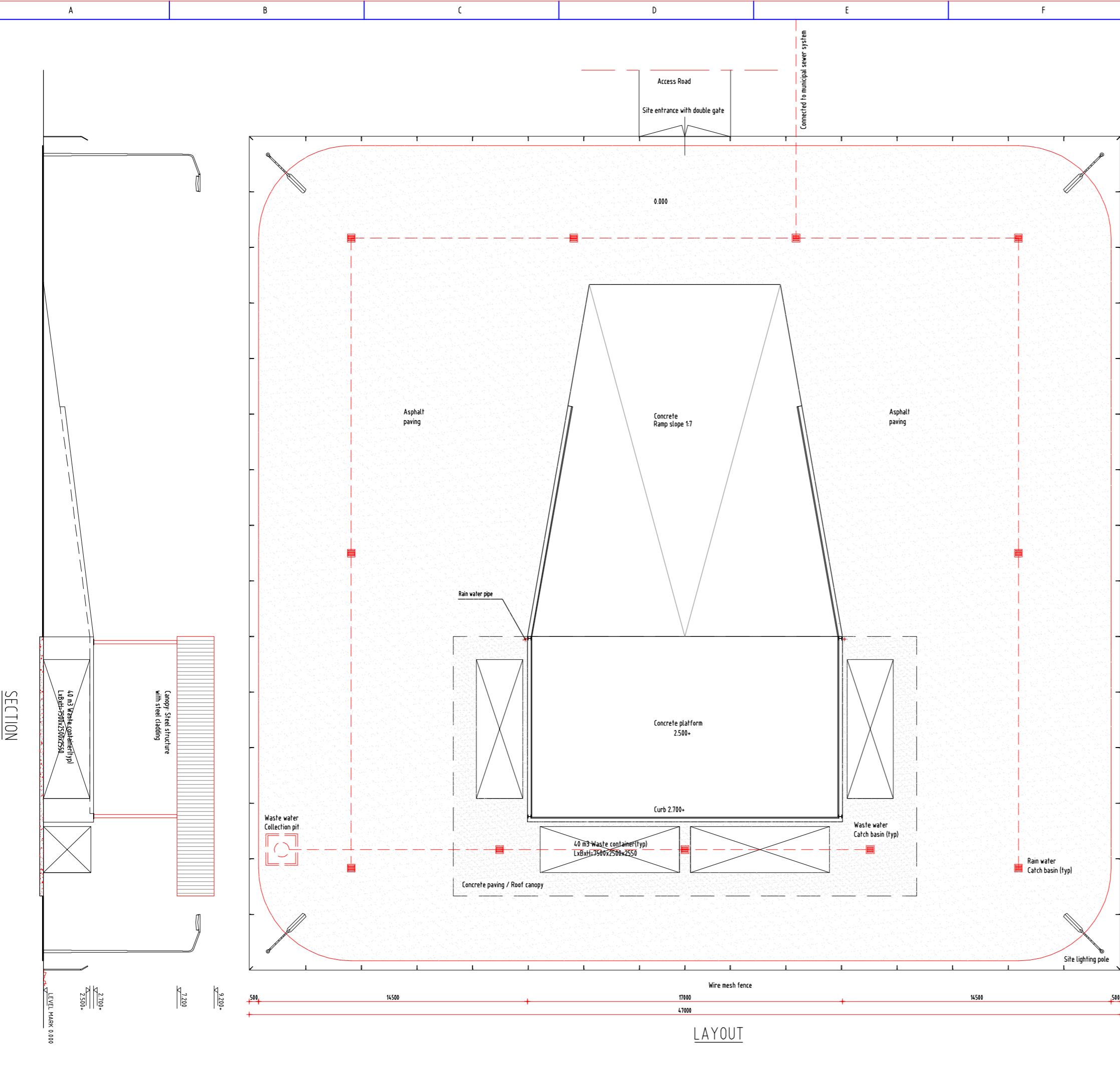

**GENERAL REMARKS**

- All dimensions in mm
- Elevations in meters related to 0.000
- Level mark = 0.000 = ... High point of asphalt paving
- On all visible concrete corners to be chamfered

A	08-10-'04	Rempec Comments	JBRR		
0	12-08-'04	Comments	DEB	H.H	
Rev.	Date	Description	Drawn by	Okd	Seen by
Client			REMPEC		
Project			Port Reception Facilities		
		<p>Title</p> <p>Typical layout and section Garbage Transfer Station For quantities of &gt; 2000 m<sup>3</sup>/Year</p>			
Branch office	Dept.	Scale	Size	Order number	Sub
THE HAGUE	11	1:100	A-1	33202	00
Drawing number		Sh		of	
33002052		1		1	
Rev.					A



## Appendix E: Overview of Technical Codes and Standards

Abbreviations and Acronyms: where abbreviations and acronyms are used in Specifications they shall mean the following:

### Codes and Standards

AIAA:	American Institute of Architects
AISI:	American Iron and Steel Institute
BS:	British Standards Institution / BS Standards
CENELEC:	European Committee for Electrotechnical Standardisation
DIN:	Deutsches Institute for Normung/DIN Standards
EN:	European Standards
IEC:	International Electro technical Commission
ISO:	International Organization for Standardization
SA:	Svensk Standard Sweden / SA Standards

### Abbreviations

EPDM:	Ethylene Propylene Diene, Ethylene Propylene rubbers
GRE:	glass fibre reinforced epoxy
GRP:	glass fibre reinforced thermosetting plastic
kPa:	kilo Pascal, indication of pressure in kilo Pascals
MPa:	Mega Pascal, indication of pressure in Mega Pascals
N:	Newton, indication of force in Newton
PN:	Pressure Nominal, nominal pressure indicated in bar
SBS-bitumen:	SBS modified bitumen waterproof materials, self adhesive bitumen
WS No.:	material number according to DIN, e.g.: 1.4571

---